

# StairMaster®



## STEPMILL 7000 PT ASSEMBLY INSTRUCTIONS



## ASSEMBLY INSTRUCTIONS

### ***TOOLS REQUIRED:***

- KNIFE
- 2-9/16" WRENCHES
- 5/32" ALLEN WRENCH

1. USE KNIFE TO CUT AND REMOVE PLASTIC STRAPS.

**TOP COVER**

**PLASTIC STRAPS**



2. REMOVE TOP COVER FROM CARTON, THEN REMOVE CARTON. DISCARD COVER AND CARTON.

3. REMOVE PLASTIC BAG FROM STEPMILL.

**PLASTIC BAG**



4. USE KNIFE TO REMOVE PLASTIC TYRAPS SECURING FRAME TO PALLET. USE CLAW HAMMER TO REMOVE WOODEN PACKING BLOCKS

**WOOD BLOCK**

**TYRAPS**

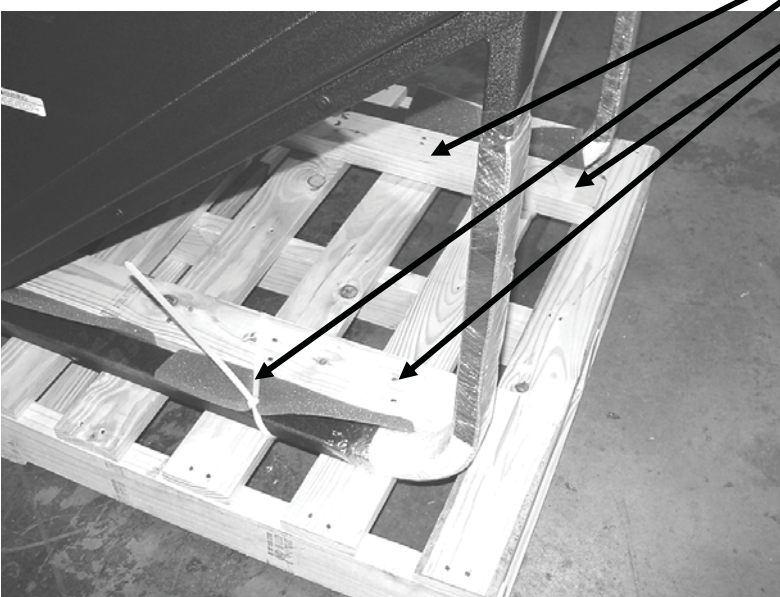

5. REMOVE STEPMILL FROM PALLET: SLIDE THE MACHINE FORWARD SO THAT THE FRONT EDGE OF THE MACHINE HANGS OFF THE FRONT OF THE PALLET. CAREFULLY TIP THE STEPMILL FORWARD UNTIL THE FRONT EDGE OF THE MACHINE TOUCHES THE FLOOR. CONTINUE TO PULL THE MACHINE FORWARD UNTIL IT IS CLEAR OF THE PALLET. GENTLY TIP THE STEPMILL BACK SO THAT THE MACHINE RESTS ON THE BASE OF THE FRAME. DISCARD PALLET.





## ASSEMBLY INSTRUCTIONS

6. REMOVE BUBBLE PACK AND CARTON FROM STEPMILL. ALSO REMOVE PACKING MATERIALS FROM HANDRAILS.

**PACKING MATERIAL**

**CARTON**

**BUBBLE PACK**

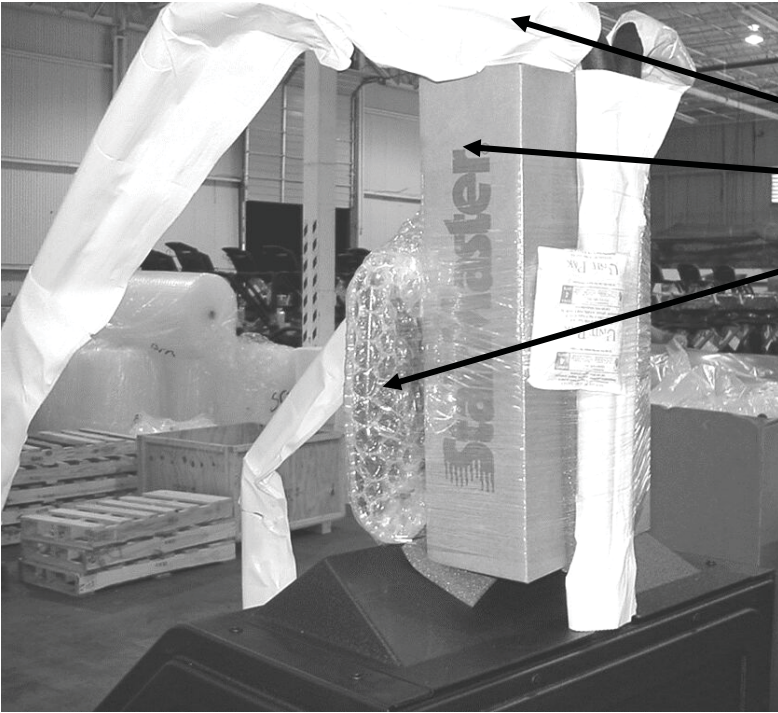

7. REMOVE CONSOLE FROM BUBBLE WRAP. DISCARD BUBBLE WRAP.

**CONSOLE**







## ASSEMBLY INSTRUCTIONS

8. USE A KNIFE TO OPEN CARTON.

CARTON



9. THE CARTON CONTAINS OWNER'S MANUAL, WHEELS, HARDWARE PLASTIC BAG, MAGAZINE RACK, CONSOLE BRACKET, AND POWER SUPPLY CARTON.





## ASSEMBLY INSTRUCTIONS

10. THE HARDWARE PLASTIC BAG CONTAINS DRINK HOLDER BRACKET, SCREW FOR MOUNTING DRINK HOLDER BRACKET, WHEEL AXLES, CLIPS, CONSOLE SCREWS, LOCK WASHERS, AND PLASTIC COVERS.

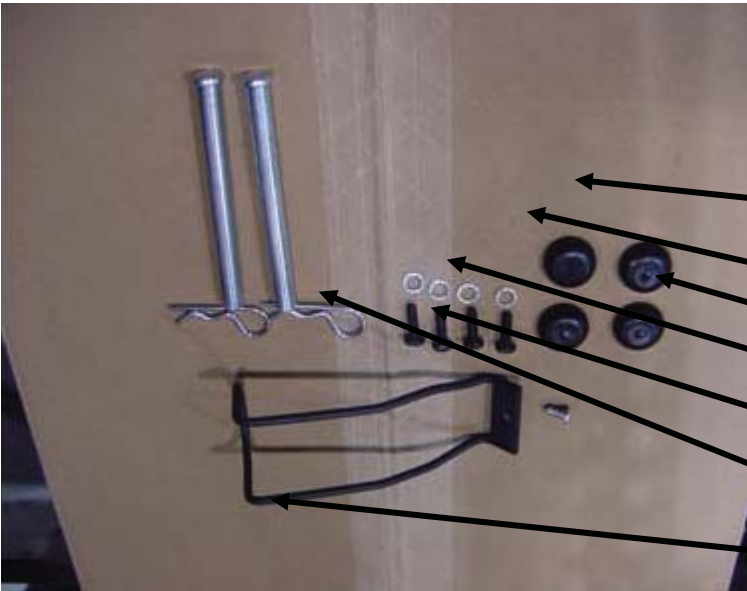

**DRINK HOLDER BRACKET SCREW**

**DRINK HOLDER BRACKET**

**PLASTIC COVER**

**CONSOLE SCREW**

**LOCK WASHER**

**CLIPS**

**WHEEL AXEL**

11. TWO WHEELS ARE USED TO MOVE THE STEP MILL TO IT'S FINAL LOCATION.

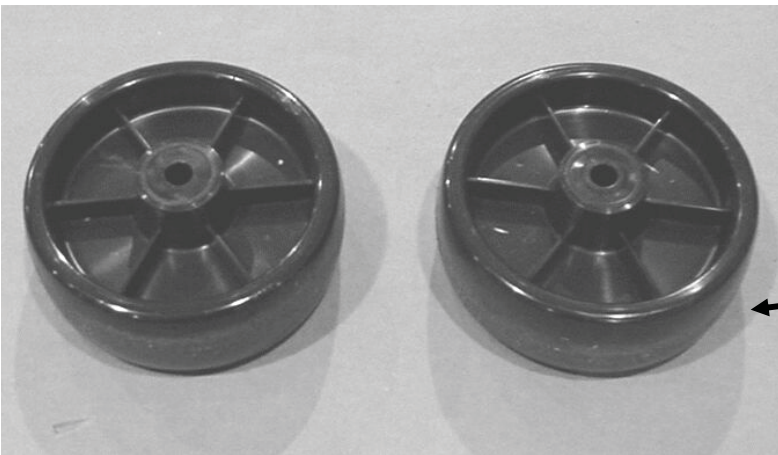

**WHEEL**

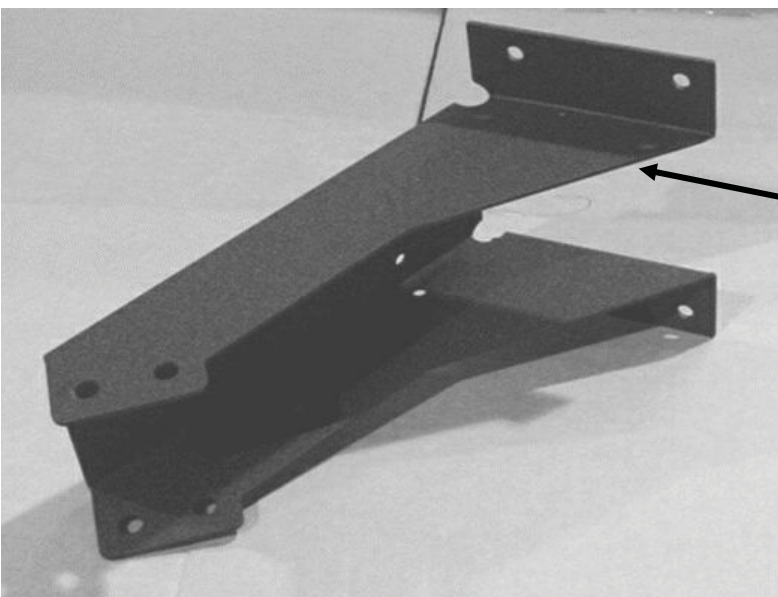

**CONSOLE BRACKET**



12. USE KNIFE TO REMOVE STRETCH WRAP FROM POWER SUPPLY BOX AND OWNER'S MANUAL. SAVE OWNER'S MANUAL FOR LATER USE. OPEN POWER SUPPLY CARTON.

**OWNER'S MANUAL**

**POWER SUPPLY CARTON**



13. THE POWER SUPPLY CARTON CONTAIN FOUR LEVELING PADS, BAG OF SPARE PUSH RIVETS, RIVET REMOVAL TOOL, AND POWER SUPPLY.

**POWER SUPPLY**

**LEVEL PAD**

**BAG OF SPARE PUSH RIVETS**

**RIVET REMOVAL TOOL**







14. USE TWO 9/16" WRENCHES AND REMOVE TWO BOLTS, FOUR FINISH WASHERS, AND TWO NUTS FROM HANDRAILS.

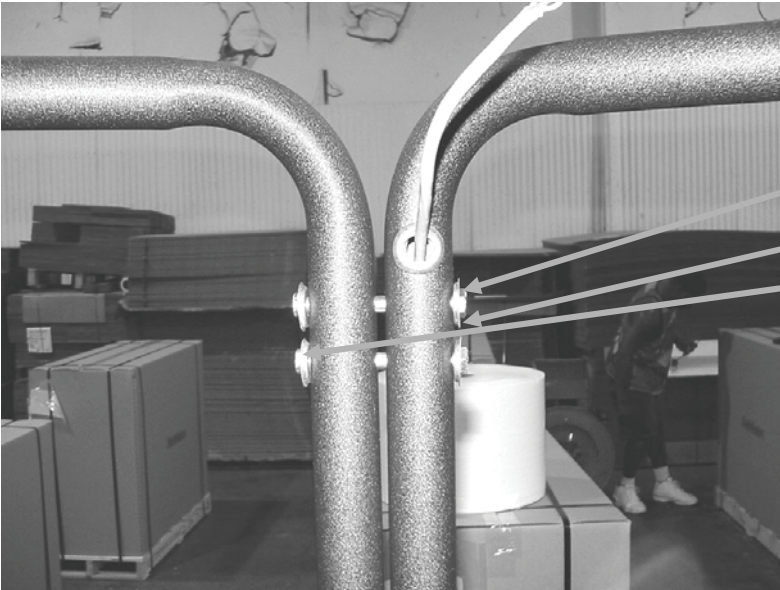

**BOLT**

**FINISH WASHER**

**NUT**

15. GET CONSOLE BRACKET FROM CARTON AND POSITION OVER HANDRAILS. INSTALL BOLTS, FINISH WASHERS, AND NUTS TO SECURE CONSOLE BRACKET TO HANDRAILS. USE 9/16" WRENCHES TO TIGHTEN BOLTS.

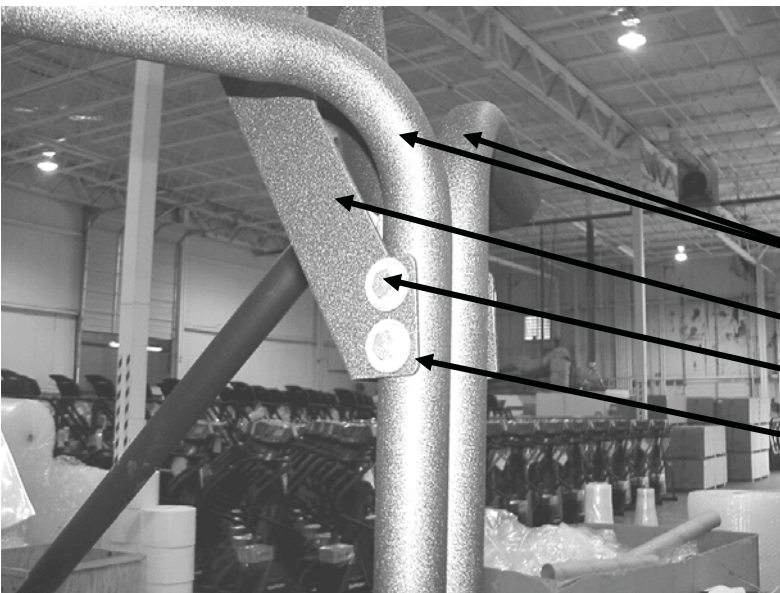

**HANDRAIL**

**CONSOLE BRACKET**

**BOLT**

**FINISH WASHER**



## ASSEMBLY INSTRUCTIONS

16. GET FOUR PLASTIC COVERS AND SNAP ONTO THE FINISH WASHERS TO COVER THE TWO BOLT HEADS AND NUTS.

**PLASTIC COVER**

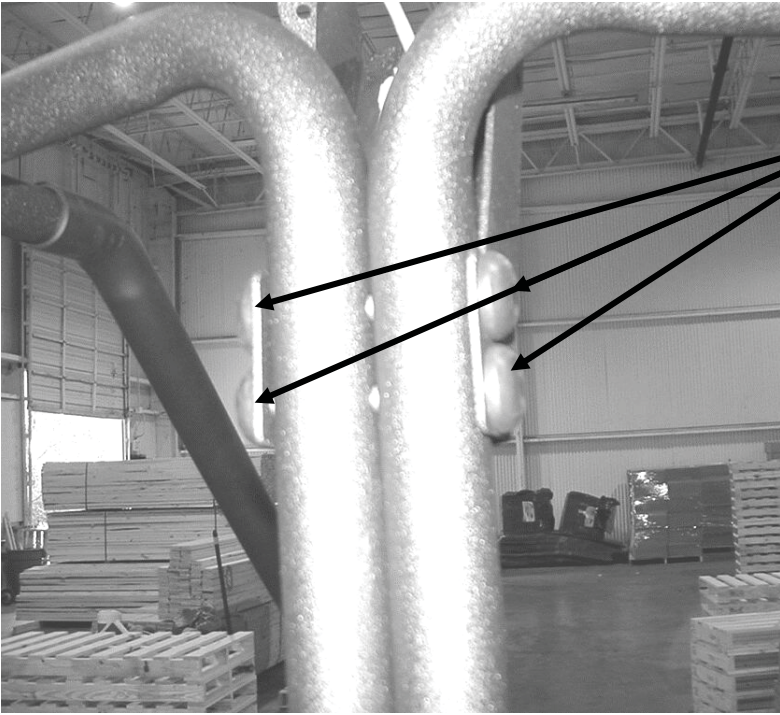

17. USE A 5/32" ALLEN WRENCH TO ATTACH THE DRINK HOLDER BRACKET TO THE CONSOLE USING THE DRINK HOLDER BRACKET SCREW.

**DRINK HOLDER BRACKET**

**DRINK HOLDER BRACKET SCREW**

**CONSOLE**







18. GET MAGAZINE RACK AND POSITION IN GROOVES IN REAR OF CONSOLE.

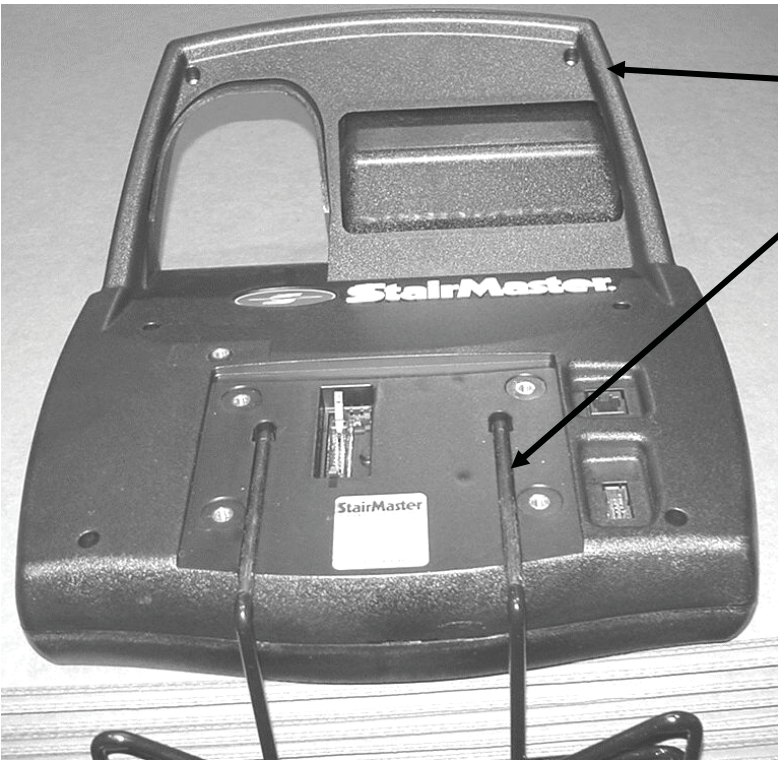

CONSOLE

MAGAZINE RACK

19. GET FOUR CONSOLE SCREWS AND LOCK WASHERS. HOLD MAGAZINE RACK INTO GROOVES IN CONSOLE WHILE POSITIONING THE CONSOLE OVER THE CONSOLE BRACKET. USE THE CONSOLE SCREWS AND LOCK WASHER TO SECURE THE CONSOLE TO THE CONSOLE BRACKET. ATTACH THE FEMALE CONNECTOR ON THE CABLE TO THE MALE CONNECTOR AT THE REAR OF THE CONSOLE. MAKE SURE TO POSITION THE CONNECTORS CORRECTLY WITH THE ALIGNING TAB ON THE FEMALE CONNECTOR WITH THE ALIGNING SLOT ON THE MALE CONNECTOR.



CONSOLE

CONSOLE KNOB

CONSOLE BRACKET

CABLE





20. GET TWO WHEELS, TWO AXLES, AND TWO CLIPS. SLIDE AXLE INTO HOLE IN BOTTOM OF FRAME. TILT STEPMILL TO ONE SIDE, SLIDE WHEEL ONTO AXLE.

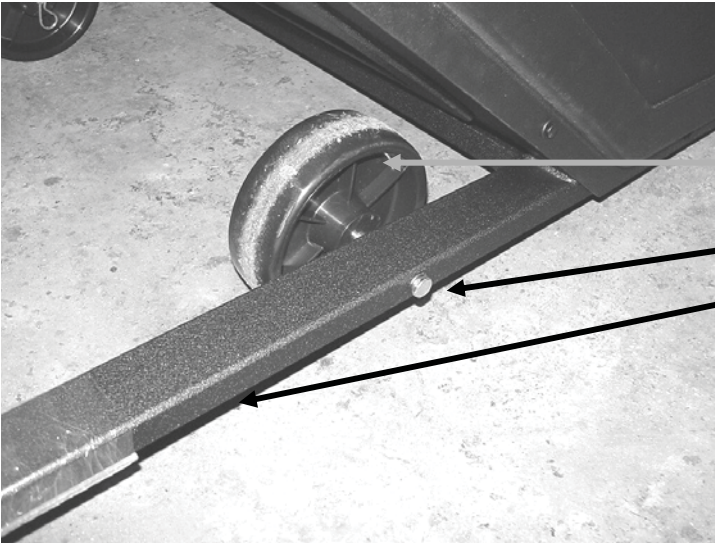

WHEEL

AXLE

FRAME

21. INSTALL CLIP INTO HOLE IN AXLE TO RETAIN WHEEL ON AXLE.

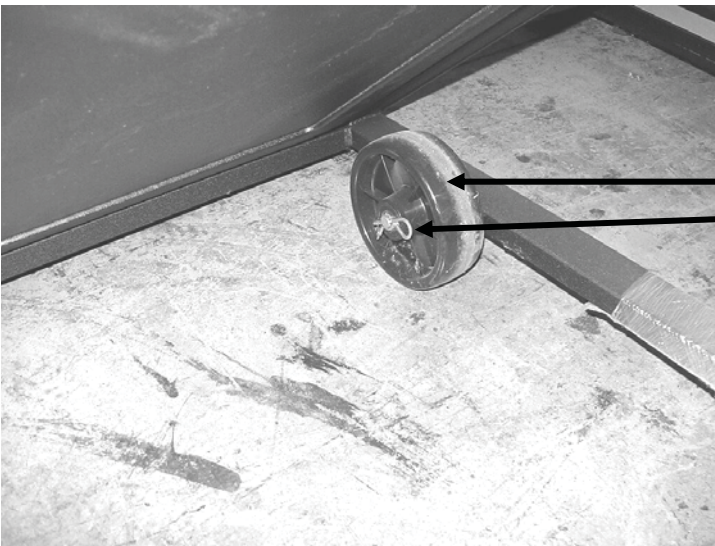

WHEEL

CLIP

22. SLIDE AXLE INTO HOLE ON OTHER SIDE OF STEPMILL BOTTOM FRAME, TILT STEPMILL TO ONE SIDE, SLIDE WHEEL ONTO AXLE. INSTALL CLIP INTO HOLE IN AXLE TO RETAIN WHEEL ON AXLE.



WHEEL

CLIP



## ASSEMBLY INSTRUCTIONS

23. REMOVE ALL PACKING MATERIALS FROM STEPMILL. ROLL STEPMILL TO FINAL LOCATION.

24. INSTALL FOUR LEVELING PADS INTO THREADED HOLES IN THE BOTTOM SURFACE OF THE STEPMILL. TILT STEPMILL AND REMOVE THE WHEELS, AXLES, AND CLIPS. RETAIN THESE ITEMS FOR FUTURE USE IF THE STEPMILL WILL BE MOVED TO A NEW LOCATION. PLUG IN POWER SUPPLY TO RIGHT SIDE OF STEPMILL AND POWER SOURCE.

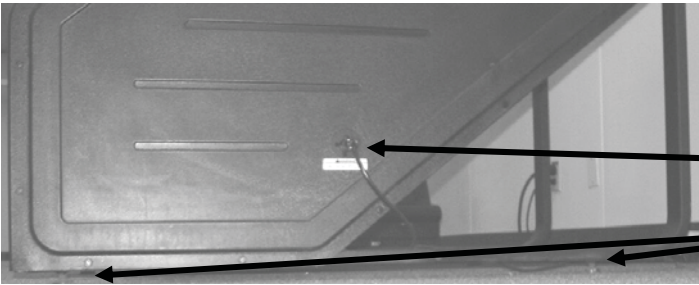

**POWER SUPPLY**

**LEVEL PADS**

25. SEE OWNER'S MANUAL FOR SET UP AND OPERATING INSTRUCTIONS.

TROUBLE SHOOTING GUIDE FOR ALTERNATORS ON STEPMILLS

Title: Stair Master Alternator Troubleshooting	Product: Nautilus Step Mills
Date: June 3, 2008	Distributed By: Gary Pendleton

We are seeing a number of Step Mills with intermittent or no resistance when stepping. Many times the problem is solved by replacing the alternator brushes or the alternator itself. Nautilus has provided some troubleshooting pointers to assist us in trouble shooting Step Mill resistance problems.

Nautilus has also requested that after following the troubleshooting procedures and we find a bad alternator, that we return failed alternators to them for analysis. **See page 4 of this Service Note for alternator return instructions.**

**1. No Resistance When Stepping**

- Remove the right side panel to view the Relay board LEDs.
- Begin moving the staircase.
- All three LEDs on the relay board are lit but there is no resistance.
  - Replace Alternator brushes or Alternator.

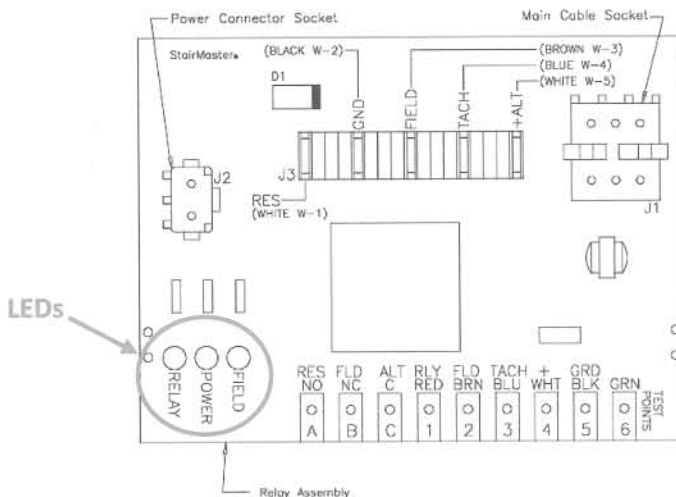

**2. Intermittent Resistance**

- Begin moving the staircase.



## TROUBLE SHOOTING GUIDE FOR ALTERNATORS ON STEPMILLS

- Staircase grabs at high speed only and Field LED lights momentarily then goes out.
- Replace Load resistor.

### 3. No Resistance and No Field Light.

- Begin moving the staircase.
- Staircase freewheels and Field LED doesn't light.
- Perform Tach test by entering diagnostics.
- If there is no Tach signal sensed on console
  - Check for .6 to .7 volts AC at the W-4 (Tach) terminal of the alternator.
  - If no voltage, remove the blue Tach wire from the alternator, while staircase is moving.
    - Touch the Tach wire to the Field terminal.
    - If the Field LED lights, Replace the alternator.
  - If the voltage checks good, remove the blue connector from the W-4 (Tach) terminal of the alternator. Lightly scrape the connector and re-install. Re-check.
  - If still bad, replace the console.

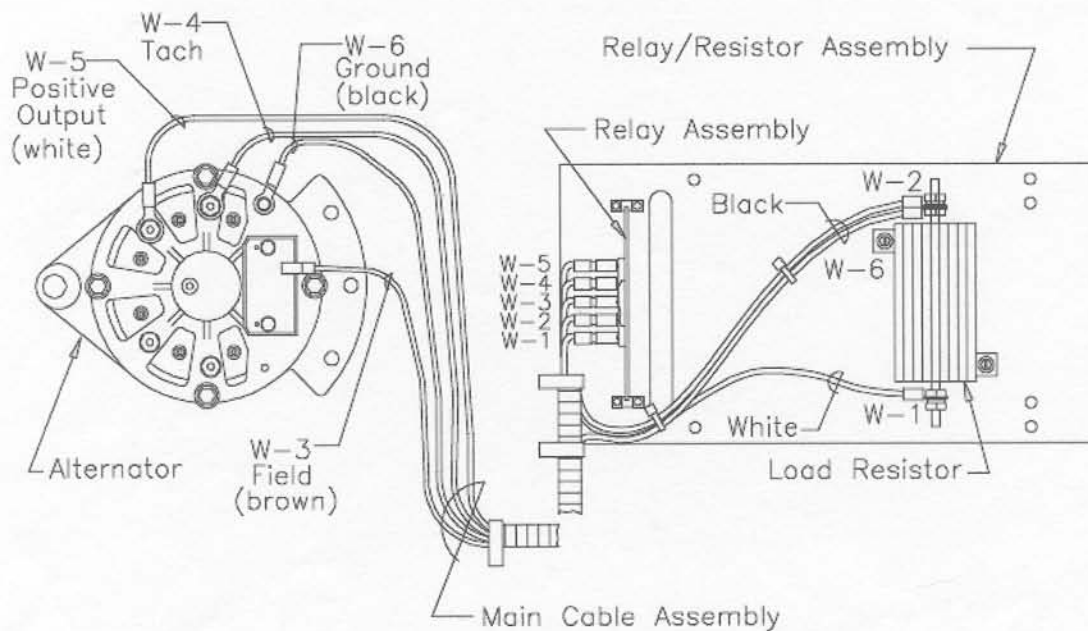

## TROUBLE SHOOTING GUIDE FOR ALTERNATORS ON STEPMILLS

### 4. Staircase has Resistance but Freewheels when Quick Start or Program is Entered.

- Replace console.

### 5. Staircase has resistance but is choppy during exercise.

- Inspect Main Cable for Corrosion at all connections.
- Check Load Resistor for a reading of .5-.6 Ohms.
- Replace alternator brushes or alternator.

### 6. Relay board tests.

- Disconnect the main cable from relay board J1 terminal.
- With power on, place jumper across GND/BLK and RLY/RED test points.
  - Relay LED should light.
- With power on, place jumper across +/WHT and FLD/BRN test points.
  - Field LED should light.
- With power on, place jumper on +/WHT and with the other end touch the ALT/C, FLD/NC, and RES/NO.
  - Field LED should light.
- If any of these jumps fail replace relay board and or power supply.

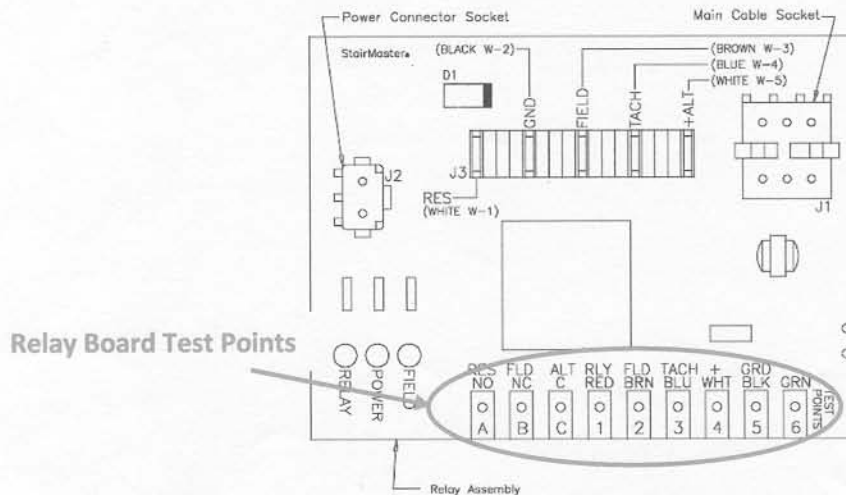

## TROUBLE SHOOTING GUIDE FOR ALTERNATORS ON STEPMILLS

### 7. Other Points

- Remember the only signal that will prevent the Field LED from lighting on the relay board is the Tach Signal on the blue wire. The console must receive an rpm signal to activate the field current to the alternator that is PWM controlled.
- If you suspect the alternator, disconnect all the wires and check the resistance across the field terminal and the alternator housing; a typical Prestolite Alternator should read around 4 Ohms.
- The Field LED on the relay board will flicker at higher speed levels. This is the PWM signal from the console to the field terminal of the alternator to control resistance / speed. If you experience full resistance through all levels and the field light doesn't flicker; replace the console.
- Always perform mechanical troubleshooting in addition to electrical trouble shooting for resistance problems.

### 8. Alternator return instructions

Failed alternators are to be returned to:

**Joe Polaro**  
**Southeast Service Manager/  
Field Quality & Reliability Specialist**  
**55 Westwood Drive**  
**Ruckersville, Virginia 22968**

Please include in the package the Step Mill Serial Number, the number of miles and number of hours. Include the failure symptoms and ship the alternators complete, do not remove the brushes.

Ship the complete alternator via UPS using account number 7R4A03.





# FreeClimber® 7000 PT Owner's Manual



**StairMaster**

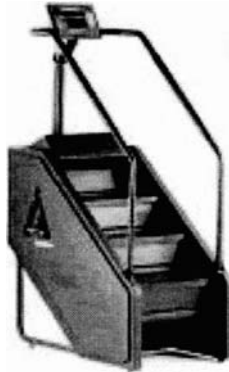

Printed in the United States.  
© 1996 StairMaster® Sports/Medical Products, Inc.  
All rights reserved.

Corporate Headquarters  
12421 Willows Road N.E., Suite 100  
Kirkland, WA 98034

(800) 635-2936  
(425) 823-1825  
Fax (425) 823-9490

**StairMaster**



PN 22440-A

© 1996 StairMaster Sports/Medical Products, Inc.. StairMaster and Stepmill are registered trademarks and 7000 PT is a trademark of StairMaster Sports/Medical Products, Inc.



## WARRANTY

This is to certify that the StairMaster @Stepmill @7000 PT™ exercise system is warranted by StairMaster Sports/Medical Products, Inc. to be free of all defects in materials and workmanship. This warranty does not apply to any defect caused by negligence, misuse, accident, alteration, improper maintenance, or an "act of God". This warranty is non-transferable from the original owner.

If, within three years from the date of purchase, any part of the StairMaster Stepmill 7000 PT exercise system should fail to operate properly contact our Customer Service Department to report the problem. International customers may contact their local distributor. When calling, please be prepared to provide the customer service representative with the following information:

- Your name, shipping address, and telephone number;
- The model and serial number of the inoperable machine;
- The date(s) of purchase for the inoperable machine(s);
- Your billing address.

This information will ensure that you are the only one ordering parts under your warranty protection. If warranty replacement parts are shipped to you, you may be required to return the inoperable part. To facilitate this process, the following policy has been established:

- Please call our Customer Service Department to receive a return goods authorization prior to shipment.
- StairMaster Sports/Medical Products, Inc. will incur all freight charges for warranty parts ordered for a machine that is less than 45 days old. The parts will be shipped to you via an overnight courier.\*
- You are responsible for freight charges on warranty parts for machines that are more than 45 days old. You will not be responsible for the return shipment of the inoperable parts.
- Some inoperable warranty parts must be promptly returned to our Customer Service Department. We will pay the return shipping cost for the inoperable warranty parts. Detailed shipping instructions are included with each warranty replacement part.

StairMaster Sports/Medical Products, Inc. neither makes, assumes nor authorizes any representative or other person to make or assume for us, any other warranty whatsoever, whether expressed or implied, in connection with the sale, service, or shipment of our products. We reserve the right to make changes and improvements in our products without incurring any obligation to similarly alter products previously purchased. In order to maintain your product warranty and to ensure the safe and efficient operation of your machine, only authorized replacement parts can be used. This warranty is void if parts other than those provided by StairMaster Sports/Medical Products, Inc. are used.

\* Note: Aerosol products cannot be transported via air.





## INTRODUCTION

The StairMaster® Stepmill® 7000 PT™ exercise system is a safe, functional, and effective exercise modality for developing aerobic fitness and increasing the strength of the major muscle groups of the lower body. It is designed for use by individuals of all ages and fitness levels. Your purchase of this machine is a positive affirmation of your commitment to use the best available methods for enhancing your functional fitness capabilities. In order to derive optimal benefits from your machine, you should read this manual thoroughly and adhere closely to the instructions.

### WHAT IS IN THIS MANUAL?

Following the information on installation and a brief explanation of how the Stepmill7000 PT exercise system works, this manual contains two major sections. The first section provides an explanation of how the machine should be used to achieve maximum results. The second section offers instructions and advice on how to properly maintain your machine. The "Appendix" contains additional information for the owner.

Throughout this Manual, whenever you are required to enter information into the console, the console keypad keystrokes are enclosed in [ ]. The names of the buttons and special console operational modes are shown in capital letters. For example, your machine is ready for use when the console is in the ATIRACT mode. You are then required to press the [MANUAL] button to start the MANUAL exercise program.

### WHAT IS THE STAIRMASTER STEPMILL 7000 PT EXERCISE SYSTEM?

The StairMaster Stepmill7000 PT exercise system is a vertical climbing machine with a rotating staircase which provides an aerobic workout equivalent to climbing stairs, without the impact loads and skeletal trauma common to most aerobic activities. Regular use of the Stepmill 7000 PT exercise system strengthens and conditions the heart and the following lower body muscle groups: gluteals, quadriceps, hamstrings, and calf muscles.



## CONTENTS

SAFETY GUIDELINES	1
INSTALLATION INSTRUCTIONS	3
BASIC OPERATING INSTRUCTIONS	6
General Guidelines For Safe Operation	6
Your First Workout	6
CONSOLE	9
The Text Bar	9
The Display	9
The Function Keypad	10
The Exercise Program Keypad	11
Customizing Your Exercise Program	20
Customizing the Text Bar Scrolling Message	20
Console Codes	23
MAINTENANCE INSTRUCTIONS	24
Helpful Hints	24
Tool List	24
Maintenance Records	24
Initial Service	25
Preventive Maintenance	25
TROUBLESHOOTING	28
General Troubleshooting Guidelines	28
Electrical System	28
Console Diagnostic Tests	31
Speed Control Problems	33
Load Resistor Test	36
Drive Train	37
PARTS REMOVAL AND REPLACEMENT	40
Alternator Assembly	47
Cable Assembly	45
Console	41
Covers	40
Drive Chain	42
Poly-V Belt	41
Relay/Resistor Assembly	47
Step Assembly	42
Step Chain Assembly	43



## CONTENTS

Transmission Assembly	46
Upper (and Lower) Sprocket Assembly	44
GROUNDING INSTRUCTIONS	48
FCC COMPLIANCE	49
APPENDICES	
How to Order Parts	50
Figures 10 -17	51
Wiring Diagram 1 - 3	60
Key to Figures and Wiring Diagrams	63
LIST OF TABLES	
Table 1: Dimensions and Specifications	3
Table 2: Fitness Rating Norms	13
Table 3: Character Codes for Scrolling Messages	21
Table 4: Console Codes	23
Table 5: Recommended Preventive Maintenance Schedule	27
LIST OF ILLUSTRATIONS	
Figure 1: Console Diagram	9
Figure 2: Fat Burner	14
Figure 3: Fat Burner Plus	15
Figure 4: Steady Pace	16
Figure 5: Rolling Hills	16
Figure 6: Aerobic Training	17
Figure 7: Cross-Country	18
Figure 8:Speed Training	19
Figure 9: Grounding System	48
Figure 10: Installation Diagram	51
Figure 11: Parts Needing Periodic Lubrication	52
Figure 12: Side Cover and Handrail Assemblies	53
Figure 13: Cover Fasteners	54
Figure 14: Poly-V Belt Tension	55
Figure 15: Drive Chain Assembly	56
Figure 16: Step Assembly	57
Figure 17: Step Chain and Sprocket Assemblies	58
Figure 18: Transmission and Alternator Assemblies	59
Wiring Diagram 1	60
Wiring Diagram 2	61
Wiring Diagram 3	62



## SAFETY GUIDELINES

---

### **IMPORTANT SAFETY INSTRUCTIONS**

---

When using electrical equipment, basic precautions should always be followed, including:

Read all instructions before using the machine.

#### **IDANGERI**

To reduce the risk of electric shock, always unplug the external power supply from the AC wall outlet before cleaning, maintaining, or repairing.

#### **IWARNINGI**

To reduce the risk of burns, electric shock, or injury to persons:

1. The external power supply should always be unplugged from the AC wall outlet before removing or installing parts. Never make adjustments or repairs while an exercise program is in progress.
2. Close supervision is necessary whenever the machine is used by, on, or near children, invalids, or disabled persons.
3. Keep your hands away from all moving parts and keep your feet on the pedals while exercising. Do not operate with the side covers removed.
4. Use this machine only for its intended use as described in this Manual. Do not use attachments or accessories other than those provided by StairMaster Sports/Medical Products, Inc.
5. Do not use the external power supply if it has a damaged cord or plug, if it is not working properly, if it has been dropped or damaged, or dropped into water. Contact our Customer Service Department at (800) 331-3578 to arrange for the return of damaged parts. International customers should contact their local distributor; refer to the Appendix for the appropriate phone number.





## SAFETY GUIDELINES

6. Connect the external power supply to a properly grounded AC wall outlet; refer to the "Grounding Instructions" section of this Manual. Keep all cords away from heated surfaces.
7. Never drop or insert any object into any opening on the machine.
8. Do not use the machine outdoors.
9. Do not operate where aerosol (spray) products are being used.
10. To disconnect the external power supply, remove the plug from the AC wall outlet.

The safety level given by the design of this equipment can only be maintained when the equipment is regularly examined for damage and wear. Inoperable components shall be replaced immediately or the equipment shall be put out of use until it is repaired.

Failure to follow all guidelines may compromise the effectiveness of the exercise experience, expose yourself (and possibly others) to injury, and reduce the longevity of the machine.

**| SAVE THESE INSTRUCTIONS |**

## INSTALLATION INSTRUCTIONS

Before leaving the manufacturing facility in Tulsa, Oklahoma, your StairMaster® Stepmill® 7000 PT™ exercise system was thoroughly inspected and tested for proper operation. To minimize shipping damage, careful attention was given to making your machine ready for shipment.

The dimensions of the machine are listed in Table 1. Throughout the *Owner's Manual*, all references to the left or right side and to the front or back are made as if you were on the machine, ready to exercise. For example, the white function keypad is located on the right side of the console.

**Table 1. Dimensions and Specifications for the StairMaster 7000 PT Exercise System**

<b>Physical Dimensions:</b>	
Length	50.0 inches (127 cm)
Width	29.0 inches (74 cm)
Height	78.0 inches (198 cm)
Weight	409 pounds (186 kg)
<b>Power Supply Specifications, PS 7:</b>	
Output Voltage	10 to 16 VDC
Output Current Capacity	2.5 amps
Input Power Consumption	55 watts

The machine requires minor assembly before operation. You will need a pair of diagonal cutters or a pair of heavy-duty scissors. The Stepmill 7000 PT exercise system must be placed on a solid, level floor near an AC wall outlet. A minimum ceiling height of 9 feet (2.8 meters) and a doorway width of 29 inches (74 cm) is required.

1. Roll the machine to its desired location on its temporary wheels.
2. Have an assistant tilt the machine forward until the wheels are off the floor. Make sure the assistant can support the machine so you can remove the temporary wheels (refer to Figure 10).
3. Remove the pin from each axle. Remove both axles and wheels from the frame.



## INSTALLATION INSTRUCTIONS

4. Help your assistant lower the machine to the floor.
5. Adjust the leg levelers as necessary to level the machine.
6. If your machine was shipped outside North America, it will need additional assembly (if this is not the case, skip to step #7).
  - Use the fastener removal tool to remove the 10 fasteners on the back cover.
  - Mount both handrails using the hardware as shown in Figure 10.
  - Push the console cable assembly through the grommet in the frame and connect it to the main cable assembly (refer to Wiring Diagram 1).
  - Install the console mount onto the handrails (refer to Figure 10).
  - Install the console and connect the console cable.
  - Reinstall the back cover.
  - Go to step #9.
7. Unwrap the power supply assembly from the console.
8. Connect the DC power cable to the power connector located on the bottom cover.
9. Place the power supply on the floor near an AC wall outlet. To reduce the hazard of electrical shock, place the power supply in a location away from the machine and away from exposure to perspiration. You should not place your power supply on a carpet because it may overheat.
10. Check to be sure that the input AC power rating marked on the power supply matches the available power. If it does not, obtain the matching power supply from StairMaster® Sports/Medical Products, Inc. before proceeding any further.



### **WARNING**

TO REDUCE THE RISK OF ELECTRICAL SHOCK AND FIRE AND TO PREVENT SEVERE DAMAGE TO THE MACHINE, USE ONLY THE POWER SUPPLY APPROVED FOR USE WITH THIS EQUIPMENT. IN ADDITION, YOUR MACHINE MUST BE PROPERLY GROUNDED.



## INSTALLATION INSTRUCTIONS

11. Connect the AC power cord to the AC wall outlet. Refer to the "Grounding Instructions" section of the *Owner's Manual* if the AC wall outlet does not accept a three-prong plug.
12. Watch the console. It should produce an audible sound when plugged in and then display a simulated EKG after the software revision level scrolling message. If it does not, unplug the power supply and then plug it back in. If the sound and/or the display are still not present, contact the Customer Service Department at (800) 331-3578. International customers should call their local distributor; refer to the Appendix "How to Order Parts" for the phone number of the office nearest you.
13. When the console displays the simulated EKG, your Stepmill® 7000 PT™ exercise system is in the ATTRACT mode.
14. The console is set at the manufacturing facility to English language prompts and English units. While the console is in the ATTRACT mode, you can set the console for foreign language prompts or metric units. To change the language of the prompts, press [+ ARROW], [7], [4], [2], [4], [ENTER]. Press the code number corresponding to the desired language according to Table 4 and then [ENTER].  
  
To change the console to metric units, press [+ ARROW], [9], [7], [6], [0], [ENTER]. Press [1], [ENTER] to set the console to metric units. Press [0], [ENTER] to set the console to English units.
15. Custom-length DC cables, brackets for multiple power supplies and other accessories are available. Refer to the Appendix "How to Order Parts" for the phone number of the office nearest you.



## BASIC OPERATING INSTRUCTIONS

### GENERAL GUIDELINES FOR SAFE OPERATION



#### **WARNING**

THESE GUIDELINES ARE DIRECTED TO YOU, AS THE OWNER OF THE MACHINE. YOU SHOULD INSIST THAT ALL USERS FOLLOW THE SAME GUIDELINES. YOU SHOULD MAKE THIS MANUAL AVAILABLE TO ALL USERS.

1. Obtain a complete physical examination from your medical doctor and enlist a health/fitness professional's aid in developing an exercise program suitable for your current health status.
2. When working out for the first time, use the MANUAL exercise program at the lower speeds until you feel comfortable and capable of faster speeds.
3. The speed and duration of your exercise program should always be subject to how you feel. Never permit peer pressure to exceed your personal judgment while exercising.
4. Overweight or severely deconditioned individuals should be particularly cautious when using the machine for the first time. Even though such individuals may not have histories of serious physical problems, they may perceive the exercise to be far less intense than it really is, resulting in the possibility of overexertion or injury.
5. Although all equipment manufactured by StairMaster Sports/Medical Products, Inc. has been thoroughly inspected by the manufacturing facility prior to shipment, proper installation and regular maintenance are required to ensure safety. Maintenance is the sole responsibility of the owner.

### **YOUR FIRST WORKOUT ON THE STAIRMASTER® STEPMILL® 7000 PT™ EXERCISE SYSTEM**

#### The ATIRACT Mode

The StairMaster Stepmill 7000 PT exercise system is ready to use when the console is in the inactive or ATTRACT mode. The ATIRACT mode is denoted by a simulated EKG signal in the display and/or a typewritten message that scrolls across the text bar.

You can program your own message to scroll across the text bar. Refer to the "Customizing the Text Bar Scrolling Message" section of this *Manual*. A diagram of the

## BASIC OPERATING INSTRUCTIONS

console is shown in Figure 1.

### Basic Instructions for First-Time Users

1. Warm up with light calisthenics and easy stretching exercises for at least five minutes before beginning your exercise program



### WARNING

IF AT ANY TIME DURING YOUR WORKOUT YOU FEEL CHEST PAIN, EXPERIENCE SEVERE MUSCULAR DISCOMFORT, FEEL FAINT, OR ARE SHORT OF BREATH, STOP EXERCISING IMMEDIATELY. IF THE CONDITION PERSISTS, YOU SHOULD CONSULT YOUR MEDICAL DOCTOR IMMEDIATELY

2. Hold onto the handrails and step up onto the staircase. Stand up straight. The steps will rotate slowly.
3. Select the MANUAL exercise program so you can control the pace of your first workout and get used to the exercise motion.
4. Press [MANUAL] and then [ENTER]. The console will return to the ATIRACT mode if you do not press [ENTER] within ten seconds.
5. The console will prompt you to enter your body weight. Enter your weight in pounds (or kilograms if the console is set up for metric units). Correct entry errors by pressing [CLEAR] before you press [ENTER].
6. The console will prompt you to enter the workout time in one-minute increments between five and 45 minutes. Press [1], [0], [ENTER] to exercise for ten minutes.
7. Step up with one foot at a time. Try to step at the top of the staircase. When you begin to exercise, the console will display a single flashing light in the first interval.
8. The flashing column shows which interval is active. Everything to the left of the active interval indicates completed intervals. As you become comfortable with the exercise motion, try pressing [+ ARROW] and [- ARROW] to adjust your speed.
9. Relax as much as possible while exercising and maintain an erect posture. Use the handrails for balance. Don't lock your elbows or lean on the console. Supporting your weight will reduce the exercise intensity and the console will



## BASIC OPERATING INSTRUCTIONS

- 0. overestimate the number of calories burned.  
Select a speed (or intensity level) that allows you to step towards the top of the staircase. Faster is not always better. Exercise at a level that is consistent with your fitness level.
- 1. You can stop once and rest for up to two minutes at any time during the workout. To rest, simply stop climbing and step down to the floor or press [RESET] (the stairs will continue to rotate very slowly). To resume your workout, press [YES] and begin climbing. To return the console the ATTRACT mode, press [NO] during the pause. The console returns to the ATTRACT mode if you rest longer than two minutes or take two rest breaks.
- 2. When you have completed the last interval of the workout, the machine will slow down to the slowest speed. Step *off* the machine and cool down by walking or stretching for at least five minutes.

### End-of-Workout Summary

- 1. At the end of your workout, the message "GOAL ATTAINED" will scroll across the text bar. The total number of Calories you burned during your workout is then displayed for ten seconds. During this time, you may press any of the function keypad buttons to receive feedback concerning your workout. Refer to the "Function Keypad" section of this *Manual* for details.
- 2. The summary information is stored in the console memory until the next person begins an exercise program. Press [WORKOUT STATS] to recall the summary for the last workout.

## 7000 PT CONSOLE

The StairMaster Stepmill® 7000 PT™ exercise system console is divided into four sections: the text bar, display, the function keypad, and the exercise program keypad (refer to Figure 2).

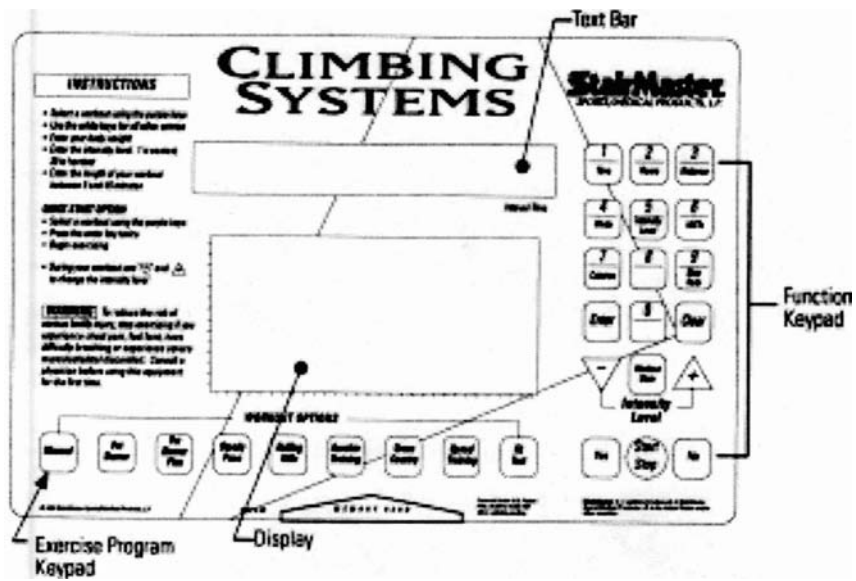

Figure 1: Console Diagram

### TEXT BAR

Information regarding workout statistics and data entry is displayed or scrolled across the text bar. A countdown timer is located directly above the words "Interval Time". The timer shows the number of seconds remaining in the current interval.

### DISPLAY

For all exercise program options except MANUAL, a profile of the selected program appears in the display. A flashing interval column indicates where on the profile you are currently exercising (the active interval). The flashing, active column moves left to right across the display area as you complete each interval.





## 7000 PT CONSOLE

### THE FUNCTION KEYPAD

The function keypad is located on the right side of the console. Eight of the buttons have two pieces of information on them—a number and a workout statistic. Before the exercise program begins, the numbers are used to enter data in response to the console prompts. During the exercise program, the buttons are used to display workout statistics on the text bar.

1. **TIME** displays the elapsed time, in minutes and seconds, of your workout.
2. **FLOORS** is the cumulative number of floors you have climbed based on an average eight-inch step and 16 steps per floor.
3. **DISTANCE** provides a cumulative total of the equivalent distance, in miles (or kilometers if your console is set to metric units), you would have traveled at the same relative intensity of exercise.
4. **WATTS** displays the physical power output of the machine. Power output is measured in units known as watts (746 watts = 1 horsepower). Since power is a rate, the watts do not accumulate over time. During a workout, this button provides the power output at that moment. After a workout, the average power output over the entire workout is shown.
5. **INTENSITY LEVEL** shows the current level between 1 (the easiest) and 20 (the hardest).
6. **METs** gives you the relative energy cost of exercise. One MET is equivalent to the resting oxygen consumption of about 3.5 milliliters of oxygen per kilogram of body mass per minute (ml O<sub>2</sub>kg<sup>-1</sup> min<sup>-1</sup>). For example, exercising at 10 METs requires ten times the resting metabolic rate or about 35 ml O<sub>2</sub>kg<sup>-1</sup> min<sup>-1</sup>. During the exercise program, this button displays the current MET level. After your exercise program, the average MET level is displayed.
7. **CALORIES** provides a running total of the Calories burned during a workout. Calories expended is a common way to measure the energy cost of exercise. Since the energy content of food is expressed in Calories, a convenient way exists to control or manage your body weight. When your total energy intake is less than your total energy output, you lose weight and vice versa. Technically, a Calorie is the amount of heat needed to raise the temperature of one liter (or one kilogram) of water one degree Celsius.



## 7000 PT CONSOLE

8. **STEP RATE** indicates the exercise speed, using the number of eight-inch steps per minute for units.
9. The **ENTER** button confirms selections and stores the information used to calculate the workout statistics in the console memory.
10. The **CLEAR** button erases data from the console before the ENTER button is pressed.
11. The **+ and • ARROWS** increase or decrease, respectively, the workout intensity level (or the number of lights during MANUAL). The intensity level ranges from 1 (the easiest) to 20 (the hardest).
12. The **WORKOUT STATS** button scrolls the eight statistics continuously across the text bar. You can press any function keypad button during the scrolling summary and stop at that statistic.

If you press [WORKOUT STATS] while the total Calories are shown on the text bar immediately after your workout, the eight statistics scroll once across the text bar. You can press any function keypad button during the scrolling summary and stop at that statistic.

Pressing [WORKOUT STATS] while the console is in the ATIRACT mode will recall the final totals of the last workout. Your workout statistics are stored in the console memory until another exercise program is started.

13. The **YES** and **NO** buttons are used to respond to data entry prompts.
14. If the **START/STOP** button is pressed while the console is in the ATIRACT mode, the "ENTER WEIGHT" prompt will appear in the display area. If it is pressed during a workout or during data entry, the console will return to the ATIRACT mode, ending the workout.

### EXERCISE PROGRAM KEYPAD

The purple exercise keypad is located below the display and to the left of the function keypad. While the console is in the ATIRACT mode, press one of the exercise program keys to preview the desired workout.

The sequence of prompts for the preset exercise programs is slightly different than the sequence described earlier for the MANUAL program. After you press one of the exercise program buttons, the exercise program profile is scrolled across the display.



## 7000 PT CONSOLE

After the profile is scrolled, the prompts are:

"PRESS ENTER KEY TO SELECT"

"ENTER BODY WEIGHT" -- type in your body weight in pounds (or kilograms if your console is set to metric units).

"ENTER LEVEL 1 - 20" -- select your intensity level with level 1 being the easiest and level 20 the hardest.

"ENTER TIME 5 - 45" -- select the workout duration in one minute increments from five to 45.

### The Quick Start Option

You can quickly start any workout by first pressing one of the purple exercise program keys and then pressing [ENTER] twice. You do not have to enter any other information. The length of the workout is set automatically and varies with the program. Quick starting MANUAL gives you a 15 minute workout. The preprogrammed workouts last five minutes for every thirty intervals. So, a 60 interval program will last 10 minutes. The only workout stats available are time, floors, distance, level, and step rate. The Fit Test does not have a quick start option.

### The Fit Test

The Fit Test is a program that estimates your maximal aerobic capacity based on your heart rate response to submaximal exercise. Start the Fit Test by pressing [FIT TEST], [ENTER] while the console is in the ATIRACT mode. You will be prompted to enter your age and gender after a short message is scrolled across the display.

Once you have entered the required information, you will step at the rate of 43 steps per minute for three minutes. At the end of the three minutes, you will need to enter your heart rate. The console will prompt you to find your pulse; use the artery below your thumb in your wrist or the artery in the side of your neck. Start counting the beats when the console prompts you-the first beat you feel is zero and then one and so on. Enter the number of beats you counted in the ten seconds. If you are using a heart rate monitor, enter your heart rate directly into the console.

You will continue to exercise for three minute bouts of increasing intensity until you reach a point where you have entered two heart rate responses between 19 and 25 counts (115-150 beats per minute). The test typically lasts from nine to 15 minutes.

At the end of the Fit Test, your results scroll across the display area. Prior to a three-minute cool down, your estimated aerobic capacity, expressed in metabolic

## 7000 PT CONSOLE

equivalents (METs) , is shown in the display area. Next, your results will be compared to normative values for others of your age and gender. These normative values are based on values developed by the world renowned exercise physiologist, Dr. Per Olaf Astrand, and are shown in Table 2. Your results are stored in the console until the next person starts an exercise program. Press [WORKOUT STATS] to review your results.

Table 2. Fitness Rating Norms

Rating	Low	Fair	Average	Above Average	Superior
<b>Gender/Age</b>					
<b>Men</b>					
29-29	<10.8	11.1-12.3	12.6-16.0	16.3-19.7	20.0+
30-39	<9.7	10.0-11.1	11.4-14.6	14.8-18.3	18.6+
40-49	<8.6	8.8-16.0	10.3-13.4	13.7-17.1	17.4+
50-59	<7.1	7.4-8.8	9.1-12.3	12.6-15.7	16.0+
60-69	<6.0	6.3-7.4	7.7-11.1	11.4-14.0	14.3+
<b>women</b>					
20-29	<8.0	8.3-9.7	10.0-13.7	14.0-16.8	17.1+
30-39	<7.7	8.0-9.4	9.7-13.4	13.7-16.6	16.8+
40-49	<7.1	7.4-8.8	9.1-12.8	13.1-16.0	16.0+
50-59	<6.0	6.3-7.7	8.0-11.7	12.0-14.0	14.3+
60-69	<4.8	5.1-6.3	6.6-10.3	10.6-12.6	12.8+

### PRESET EXERCISE PROGRAMS

There are seven preset exercise programs. The exercise speed during the programs varies automatically over 14 increments within each of the 20 different intensity levels. Varying the intensity of an exercise program does not change the profile shown on the display. Change the intensity level of your workout by pressing [+ ARROW] or [- ARROW]. The average energy cost of the exercise programs is about the same.



## 7000 PT CONSOLE

The Fat Burner program (Figure 2) is a 60 interval workout designed for people just starting a weight control program. The Fat Burner Plus program (Figure 3) is similar but has 90 intervals. It is meant for the longer workouts you will need as your fitness level increases.

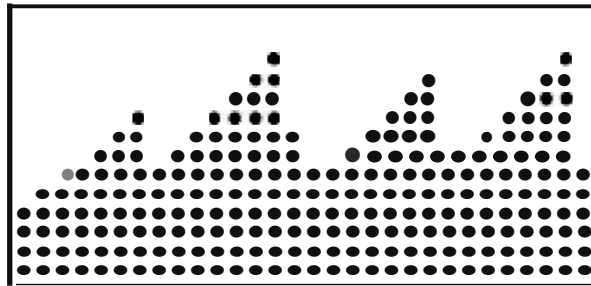

Figure 2a: Fat Burner, Screen 1



Figure 2b: Fat Burner, Screen 2



7000 PT CONSOLE

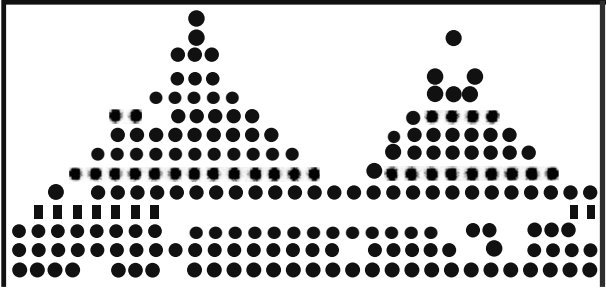

Figure 3a: Fat Burner Plus, Screen 1



Figure 3b: Fat Burner Plus, Screen 2

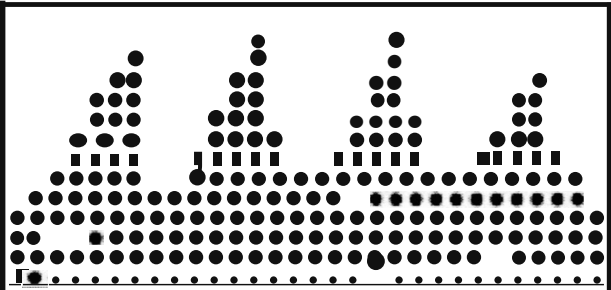

Figure 3c: Fat Burner Plus, Screen 3

## 7000 PT CONSOLE

Steady Pace and Rolling Hills (Figures 4 and 5) are 30 interval workouts with gradual speed changes. They are geared for those who are just starting to exercise or for those who need an easy day of recovery exercise.

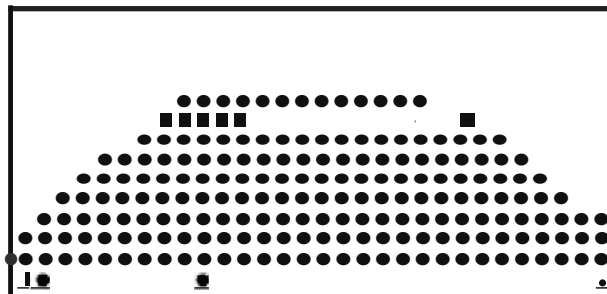

Figure 4: Steady Pace

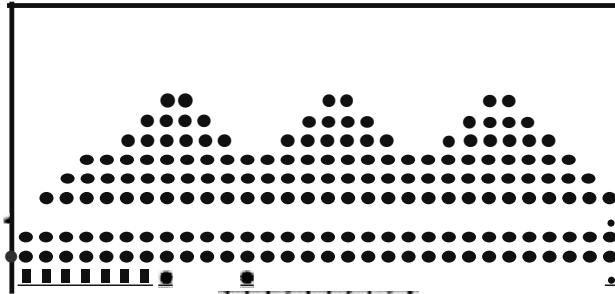

Figure 5: Rolling Hills

7000 PT CONSOLE

Aerobic Training (Figure 6) is a 60 interval workout with slightly more varied speed changes. It is ideal for those long, slow workouts to increase your aerobic capacity.

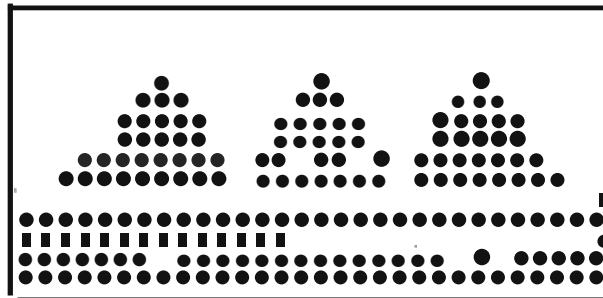

Figure 6a: Aerobic Training, Screen 1

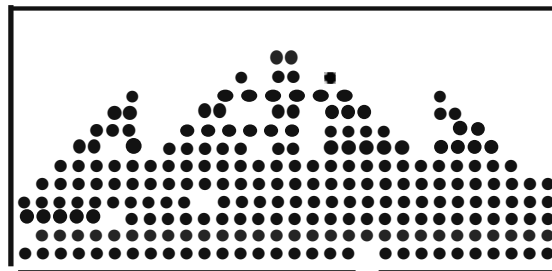

Figure 6b: Aerobic Training, Screen 2

## 7000 PT CONSOLE

Cross Country and Speed Training (Figures 7 and 8) are 90 interval workouts with lots of speed changes to get your legs moving. Think of the terrain you would find on a hike cross country.

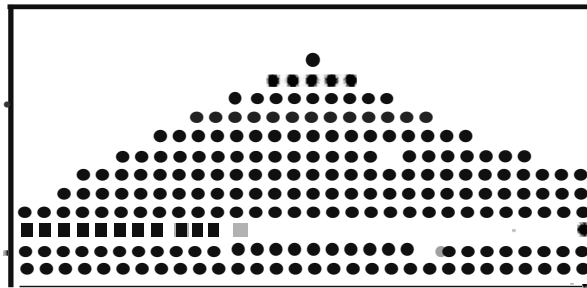

Figure 7a: Cross-Country, Screen 1

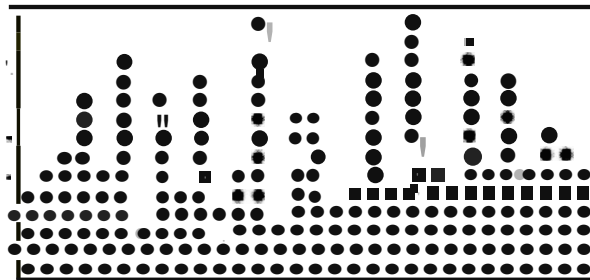

Figure 7b: Cross-Country, Screen 2

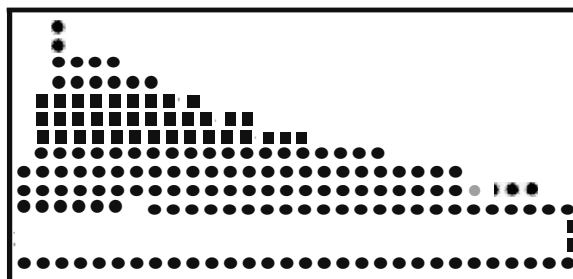

Figure 7c: Cross-Country, Screen 3



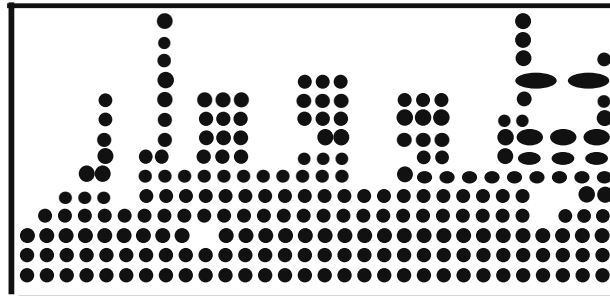

Figure 8a: Speed Training, Screen 1

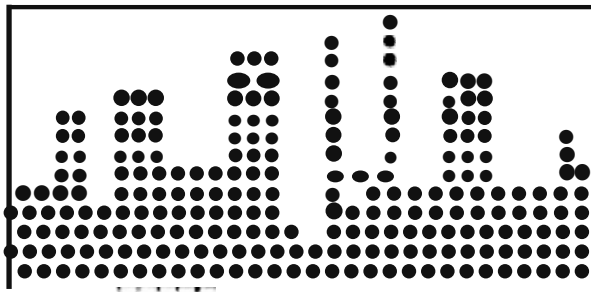

Figure 8b: Speed Training, Screen 2

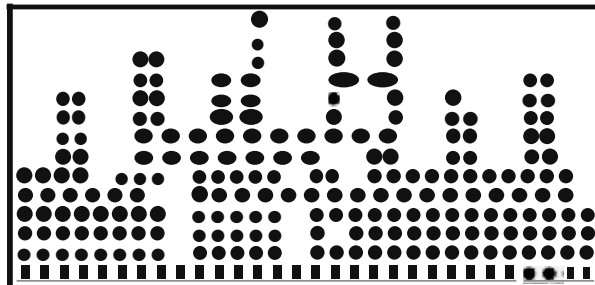

Figure 8c: Speed Training, Screen 3



## 7000 PT CONSOLE

### CUSTOMIZING YOUR EXERCISE PROGRAM

The StairMaster® Stepmill® 7000 PT™ exercise system console has enough memory space for nine exercise programs of your design. Only the exercise profile is saved, your body weight, the intensity level and the workout time must be entered each time the custom program is used.

#### Programming Your Workout

1. The console must be in the ATTRACT mode. Press [+ ARROW], [1], [6], [5], [0], [ENTER]. Press the exercise program keypad button that you want to assign to your custom program.
2. If you select an exercise program keypad button that is already programmed, the profile will appear; it can be modified or completely rewritten. If the exercise program keypad button was not previously programmed, you will see a single row of dots along the bottom of the display.
3. The flashing dot or column indicates which interval can be modified. Press the [+ ARROW] or [- ARROW] to make the column taller or shorter. Press [ENTER] to move one column to the right and [CLEAR] to move one column to the left.
4. When all of the intervals are correctly programmed, press [YES] to save the profile. Press [START/STOP] to abort the programming process without saving the profile.

#### Using a Custom Program

1. Press [- ARROW] and the exercise program keypad button you assigned to the custom program.
2. Enter your body weight, the intensity level and the workout time in response to the prompts.

### CUSTOMIZING THE TEXT BAR SCROLLING MESSAGE

The message that scrolls across the text bar during the ATTRACT mode can be replaced with a message of your choice. The console accepts messages up to 128 characters in length, including spaces. To program your message:

1. Encode your message using the character codes listed in Table 3.

## 7000 PT CONSOLE

2. While the console is in the ATTRACT mode, press [+ ARROW], [7], [6], [0], [7], [ENTER].
3. Enter the two-digit code for each letter of your message. The letter will appear in the text bar as you press the second digit of each code. Do not press [ENTER] between the code numbers.
4. For example, to program the message "EXERCISE IS FUN", press [+ ARROW], [7], [6], [0], [7], [ENTER]. Then press [1], [5], [3], [4], [1], [5], [2], [8], [1], [3], [1], [9], [2], [9], [1], [5], [1], [0], [1], [9], [2], [9], [1], [0], [1], [6], [3], [1], [2], [4], [ENTER]. At that point, your message will begin scrolling. The console is again in the ATTRACT mode.
5. If you make a mistake while entering the codes, press [CLEAR] to erase the last character entered.

**Table 3. Character Codes for the Scrolling Message**

Character	Code	Character	Code	Character	Code
a	00	M	23	r	46
1	01	N	24	A	47
2	02	O	25	i	48
3	03	P	26	E	49
4	04	Q	27	À	50
5	05	R	28	Ç	51
6	06	S	29	È	52
7	07	T	30	¿	53
8	08	U	31	+	54
9	09	V	32	\$	55
SPACE	10	W	33		56
A	11	X	34		57
B	12	Y	35	%	58
C	13	Z	36	?	59
0	14	A	37		60
E	15	O	38	!	61
F	16	O	39	-	62
G	17	B	40	#	63
H	18	A	41		64
I	19	A	42		65
J	20	O	43	)	66
K	21	E	44	(	67
L	22	N	45	/	68



## 7000 PT CONSOLE

### Editing the Scrolling Message

1. While the console is in the ATIRACT mode, press [+ ARROW], [7], [6], [0], [7], [ENTER] to display the first character of the message onto the text bar.
2. Press [+ ARROW] or [- ARROW] to scroll through the message character-by-character.
3. Press [CLEAR] to delete the last character displayed on the text bar. Press [ENTER] to end the editing process.
4. To edit multiple characters at one time, press [9], [9], [ENTER] to erase all of the characters to the right of the last character displayed on the text bar.
5. To erase the entire message, press [+ ARROW], [1], [0], [5], [ENTER] while in the ATIRACT mode.
6. The edited message will scroll across the text bar. If you have erased the entire message, the text bar area will be blank during the ATIRACT mode.
7. Press [+ ARROW], [2], [1], [2], [3], [ENTER] to display the default scrolling message on the text bar.
8. Press [+ ARROW], [2], [1], [2], [1], [ENTER] to display your custom scrolling message on the text bar.

## 7000 PT CONSOLE

### CONSOLE CODES

The console codes and the corresponding functions are listed in Table 4.

**Table 4. Console Codes**

Code	Function
+ ARROW, 105, ENTER	Clears the custom programmed scrolling message
+ARROW, 107, ENTER	Activates the Diagnostic mode
0	Display test
1	Speaker test
2	Keypad test
3	Speed Test
4	Software revision level test
+ARROW, 1650, ENTER	Programs a custom <b>workout</b>
+ARROW, 2121, ENTER	Turns on the custom scrolling message
+ARROW, 2123, ENTER	Turns off the custom scrolling message
+ARROW, 7424, ENTER	Changes the language of the console prompts
0	English
1	German
2	French
3	Italian
4	Spanish
5	Swedish
6	Danish
7	Japanese
+ARROW, 7607, ENTER	Turns on the custom message option
99, ENTER	Text bar scrolling message editing function
+ARROW, 7703, ENTER	Displays machine usage information
+ARROW, 7704, ENTER	Allows you to turn the console speaker on or off
0	Turns the speaker on
1	Turns the speaker off
+ARROW, 9760, ENTER	Allows you to change the units displayed by the console
0	Changes the console to English units
1	Changes the console to metric units



## MAINTENANCE INSTRUCTIONS

### HELPFUL HINTS

Read all maintenance instructions thoroughly before beginning work. In some cases, an assistant is required to perform the necessary tasks. The safety level given by the design of this equipment can only be maintained when the equipment is regularly examined for damage and wear. Inoperable components shall be replaced immediately or the equipment shall be put out of use until it is repaired.

All references to the right or left side and to the front or back are made as if you were on the machine ready to exercise. For example, the power supply is plugged into the connector near the bottom of the right side cover. The circled numbers in the figures identify parts that are referenced in the Parts Key of the Appendix.

### TOOL LIST

The following tools are needed to perform service and maintenance:

- standard screwdriver
- combination wrenches (sizes 7/16 - 3/4")
- combination pliers
- locking pliers
- allen wrench set (sizes 5/64 - 1/4")
- socket set or nut driver set (sizes 1/4 - 3/4" in 1/16" increments)
- phillips screwdriver
- adjustable wrench
- external snap ring pliers
- wire stripper/crimper tool
- volt-ohm meter (multimeter)
- shop goggles

### MAINTENANCE RECORDS

The console will keep track of the following data on machine usage:

- The number of hours the power supply was turned on.
- The number of hours the machine was in use.
- The total number of floors climbed.
- The number of exercise programs started.
- The hours of MANUAL use.

To display the data, press [t ARROW), [7], [7), [0), [3), [ENTER] while the console is in the ATIRACT mode. The console will display the data in the sequence listed above. The machine may show a few hours of use due to testing at the manufacturing facility.



## MAINTENANCE INSTRUCTIONS

### INITIAL SERVICE

Upon receiving your machine, use a soft, clean towel to wipe *off* the dust which may have accumulated during shipping. Your new machine will require minor assembly. Refer to the "Installation Instructions" section of this *Manual* for details.

### PREVENTIVE MAINTENANCE

The procedures for performing the recommended preventive maintenance are summarized in Table 5. The schedule is based on normal usage in a commercial health club environment; adjust the schedule to meet actual machine usage. Refer to the "Parts Removal and Replacement" section of this Manual for all disassembly and assembly instructions.

### Cleaning and Inspecting

1. DO NOT USE GLASS CLEANERS OR ANY OTHER HOUSEHOLD CLEANER ON THE CONSOLE. Clean the console daily with a water-dampened cloth and wipe dry after cleaning.
2. Clean the exterior of your Stepmill® 7000 PT™ exercise system daily with soap and water.
3. Thoroughly clean the entire machine at least once a week.
4. Inspect the painted surfaces of the exposed frame for any rust, bubbling or chips during the weekly cleaning. The salt in perspiration can damage the unpainted surfaces. Repair the damaged area with a touch-up kit provided by StairMaster® Sports/Medical Products, Inc. Refer to the Parts Key for the touch-up kit part number.
5. Clean the step hinges carefully. Perspiration tends to accumulate in the hinges, and this can lead to eventual corrosion.
6. Inspect the Poly-V belt for excessive wear during the weekly cleaning. Adjust the belt tension if necessary.



### WARNING

TO AVOID INJURY DUE TO SLIPPERY PEDAL SURFACES, DO NOT USE PETROLEUM-BASED CLEANERS OR ARMORALL-TYPE PROTECTANTS

## MAINTENANCE INSTRUCTIONS

ANYWHERE ON THIS MACHINE OR THE FLOOR MATS.

### Lubrication

The StairMaster® Stepmill® 7000 PT™ exercise system has six components that require periodic lubrication: the drive chain, the two step chains, the bearing plates and the step hinges. These parts are shown in Figure 11. You will need to remove the side cover(s) to lubricate the chains and the bearing plates.

1. Place a protective mat on the floor while you are lubricating your machine. A rubber floor mat is available from StairMaster Sports/Medical Products, Inc.
2. Lubricate the chains monthly with 30W motor oil. Drip the oil onto the chain plates and rollers. Let the oil soak in for a few minutes and then remove any excess oil with a dry rag.
3. Remove the chains every three months to thoroughly clean and relubricate them. Use a mild degreaser and a stiff brush to remove dirt and corrosion from the chain. Read the instructions on the degreaser container before using.
4. Clean each bearing plate and lubricate it with multi-purpose grease every three months. The plate is lubricated to reduce friction when the step shaft bearings roll over the plate.
5. Once per month, use 30W motor oil or brush light bearing grease into the step hinges to lubricate the hinges and to prevent corrosion. Wipe off all excess lubricant.



### WARNING

TO REDUCE THE POSSIBILITY OF SLIPPING, BE SURE THE STEP AREA IS FREE OF

## MAINTENANCE INSTRUCTIONS

**Table 5. Recommended Preventive Maintenance Schedule**

PART	RECCOMENDED ACTION	FREQUENCY	CLEANER	LUBRICANT
Exterior Surfaces	Clean	Daily	Soap & water	N/A
Console	Wipe Clean	Daily	Water	N/A
Step Chain Assembly	Lubricate	Monthly or after 300 hours of use	N/A	30W motor oil
	Clean and lubricate	Quarterly or after 900 hours of use	Clean, dry rag	Multi purpose grease
Drive Chain	Lubricate	Weekly or after 70hours of use	N/A	30W motor oil
	Clean and lubricate	Quarterly or after 900 hours of use	Mild Degreaser	30W motor oil
Step Hinges	Lubricate	Monthly or after 300 hours of use	N/A	30W motor oil
Bearing Plate	Clean and lubricate	Quarterly or after 900 hours of use	Mild Degreaser	30W motor oil

\*Note: Use of lubricants other than those so specified will result in diminished performance and a shorter life span for that part.



## TROUBLESHOOTING

### GENERAL TROUBLESHOOTING GUIDELINES

This section outlines several tests to systematically identify and isolate the cause of problems in the electrical system and the drive train. This troubleshooting section is organized into four basic problem sections: Electrical System, Console Diagnostics, Speed Control, and the Drive Train. The first step is to identify the problem. Once you have identified the problem, perform all the tests in exactly the same order as written. Refer to the "Parts Removal and Replacement" section of this *Manual* for all disassembly and assembly instructions. To order a replacement part, or to get help with the troubleshooting process, contact our Customer Service Department at (800) 331-3578. International customers should contact their local distributor or call (206) 823-1825.

### TROUBLESHOOTING THE ELECTRICAL SYSTEM

The electrical system consists of: the power supply and the console. In order to identify the component that is causing the problem, you must systematically test the system. You will need a volt-ohm meter (multimeter) to conduct portions of the following procedures. The console and power supply are not serviceable by the owner. If either of these parts are inoperable, they must be replaced. Opening the console or the power supply will void the warranty.

#### The Console Fails to Power Up

- A. Perform a visual check of the machine. Check the following things first:
  1. Is the power supply plugged in?
  2. Is the indicator light lit on the power supply? If it is, proceed to step #3. If the light is not on, reset the circuit breaker. If the light is still not on, replace the power supply.
  3. Replace or exchange your console with a console you know is good and retest the machine.
- B. Verify AC power.
  1. Disconnect the AC power cord from the AC wall outlet.
  2. Verify that the AC wall outlet is supplying the correct power in one of two ways: a) Use an AC voltmeter to verify that the AC line voltage is between 100 and 120 VAC (or between 220 and 240 VAC, if applicable) at the AC wall

## TROUBLESHOOTING THE ELECTRICAL SYSTEM

outlet; or b) Plug in an alternate AC-powered device (a lamp, for example). If the AC wall outlet is supplying the correct power, proceed to step #3. If the voltage is outside the range or if the device does not work when plugged into the AC wall outlet, consult an electrician for further assistance and then retest the AC wall outlet.

3. Plug the AC power cord into the wall outlet and proceed to the next section.

### C. Verify DC power.

1. Make sure that the AC power cord is plugged in and that the AC wall outlet is delivering the proper voltage.
2. The indicator light should be lit. If it is, proceed to step #3. If the indicator is not lit, reset the circuit breaker. If the indicator light is still not lit, replace the power supply and test the new power supply.
3. Disconnect the cable from the DC power connector located on the bottom cover. Use a DC voltmeter to verify 10-16 VDC at the end of the DC cable. Pin #1 is positive and pin #2 is negative. Proceed to step #5 if the VDC is within the range. Replace the power supply if the VDC is outside the range and test the new power supply.
4. Remove the right side cover. Reconnect the DC power cable to the machine. Locate the relay/resistor circuit board located just inside the frame, midway between the top and bottom steps (refer to Wiring Diagram 1). There are three red indicator lights along the bottom edge of the relay assembly circuit board. They are labeled, from top to bottom: Field, Power, and Relay. Ensure the black and white wire power connector (labeled J2 on the relay resistor circuit board) is securely connected to the relay resistor circuit board.
  - a. The Power light should be lit. If it is, go to step #6. If it is not, disconnect the power connector from the J2 position on the relay assembly circuit board (refer to Wiring Diagram 2). Use a DC voltmeter to measure the VDC at the power connector. Hole #1 (the white wire) is positive and hole #2 (the black wire) is negative. The reading should be between 15 and 17 VDC. If you are not getting power to the connector, replace the power connector assembly and retest.
  - b. If you are getting the correct voltage at the power connector, reconnect it to the J2 position on the relay assembly circuit board.



## TROUBLESHOOTING THE ELECTRICAL SYSTEM

Disconnect the main cable connector at the J1 position of the relay assembly circuit board. Check the VDC reading at the silver tabs on the relay assembly circuit board. Tab #4 (labelled t/WHD is positive and tab #5 (labelled GND/BLK) is negative (refer to Wiring Diagram 2). You should get a reading between 15 and 17 VDC. If your reading is not within the range, replace the relay assembly circuit board and retest.

- c. If you are getting the correct voltage at tabs #4 and #5, check the VDC reading at the connector labelled position J1 on the relay assembly circuit board. Pin #4 is positive and pin #5 is negative. You should get a reading between 15 and 17 VDC. If your reading is not within the range, replace the relay assembly circuit board and retest.
  - d. If all of the above power tests produce VDC readings that are within range and the Power indicator light is still not lit, the Power indicator light is probably inoperable. Replace the relay assembly circuit board and retest.
5. Ensure that all of the wires you disconnected in steps 5a-5c are securely reconnected. Remove the console and disconnect the console cable. Use a DC voltmeter to measure the VDC at pin #9 (positive) and pin #1 (negative) of the console cable connector. You should get a reading between 15 and 17 VDC. If the reading is not within the range, replace the cable assembly and retest.
6. If the problem still exists, contact the Customer Service Department at StairMaster® Sports/Medical Products, Inc.





## CONSOLE DIAGNOSTIC TESTS

The following tests must be performed while the console is in the DIAGNOSTIC mode. To activate the DIAGNOSTIC mode, press [↑ ARROW], [1], [0], [7], [ENTER]. The numbers will not appear on the display area as you enter them. If the console fails any test, the console should be replaced or exchanged. To return to the ATTRACT mode, press either [CLEAR] or [RESET] while in the DIAGNOSTIC mode.

### Display Test

Use this test if the console display or text bar exhibits blank spots during use. This test checks for inoperable Light Emitting Diodes (LEOs) in the console display and the text bar. If any LED will not light, replace the console.

1. Press [0] to start the test.
2. All LEOs in the console display will flash on and off as a block. The 26 letters (A-Z) will scroll across the text bar.
3. Press [CLEAR] to end the test.

### Speaker Test

Use this test to make sure the console speaker is fully operational. The speaker will ascend and then descend through the musical scale.

1. Press [1] to start the test.
2. Press [ENTER] to pause the test. Press [CLEAR] to end the test.

### Keypad Test

Perform this test if you are having trouble entering data into the console. If you cannot enter the DIAGNOSTIC mode due to an inoperable keypad, replace the console.

1. Press [2] to start the test.
2. The display LEOs will light up in an L-shaped formation, representing the keypad matrix. Pressing a button on either the exercise program keypad or the function keypad will light an LED within the outline on the display that corresponds to that button's position on the console.
3. Firmly press each button. If the LED corresponding to the button you pushed does not light up, the keypad is bad and the console should be replaced.



## CONSOLE DIAGNOSTIC TESTS

4. Press [CLEAR] to test the LED and then end the test.

### Speed Test

Use this test to verify the electronic speed control routines of the console. You will need to briefly exercise on the machine for this test.

1. Press [3] to start the test.
2. The console will be set at a certain speed. The alternator speed, in RPM, is displayed on the text bar as "Target" and a single column of lights will light up on the display.
3. Begin exercising. As the stairs rotate, the text bar will alternately show the actual RPM and the target RPM.
4. Press [CLEAR] to return to the DIAGNOSTIC mode.

### Software Revision Level Test

This test allows you to check the version number of the software installed in the console.

1. Press [4] to start the test.
2. The software version number will be scrolled across the text bar. The console will automatically return to the DIAGNOSTIC mode.
3. Contact the Customer Service Department for the most current software revision update.

## SPEED CONTROL PROBLEMS

If you have problems with erratic speed control while operating the machine, the cause may be either electrical or mechanical in nature. You will have to remove the side covers to conduct most of these tests.

- A. Perform a visual check of the machine. Check the following things first:
  1. Inspect the Poly- V belt for proper tension and excessive wear. A loose belt will cause excessive noise and wear. The machine will run sluggishly if the belt is too tight.
  2. Replace a worn or frayed Poly-V belt. Adjust the belt so that there is  $1/10$ " (0.1 cm) deflection at a point midway between the alternator and transmission pulleys with fingertip pressure (refer to Figure 14).
  3. Check for proper wire connections on the alternator, relay assembly circuit board, and load resistor (refer to Wiring Diagram 3).
  4. Replace or exchange the console with another console you know is good and retest the machine.
- B. Check the relay assembly circuit board while the console is in the ATTRACT mode. You will need an assistant to complete the test of the relay assembly circuit board.
  1. Remove the right side cover. Locate the relay assembly circuit board located just inside the frame, midway between the top and bottom steps (refer to Wiring Diagram #1). There are three red indicator lights along the bottom edge of the circuit board. They are labeled, from top to bottom: Field, Power, and Relay. Ensure the black and white wire power connector (labeled J2 on the relay assembly circuit board) is securely connected to the relay assembly circuit board (refer to Wiring Diagram 2).
  2. If the Power light is lit, go to step #3. If it is not, perform the tests as described in step C-5 of the "Console Fails to Power Up" section.
  3. The relay indicator light should be lit. If it is lit, proceed to step #5. If it is not, use a jumper wire on the relay assembly circuit board. Jump the silver tabs #1 (labeled RLY/RED) and #5 (labeled GND/BLK) (refer to Wiring Diagram 3). The relay indicator should light up. If it does, go to step #4. If the relay indicator does not light up, the relay assembly circuit board must be replaced. Replace the relay assembly circuit board and retest the machine.

## SPEED CONTROL PROBLEMS

4. You must check the cable assembly for continuity if the relay indicator lit up when you jumped tabs #1 and #5.
  - a. Unplug the main cable from the position labeled J1 on the relay assembly circuit board. Disconnect the console cable from the back of the console. Set your multimeter to the continuity check mode; on most meters, this will be the resistance or ohms setting.
  - b. Place one lead of the multimeter on pin #1 at the console connector end of the console cable (refer to Wiring Diagram 1). Place the other lead on pin #1 at the end of the main cable you disconnected from the relay assembly circuit board. You will get a reading of near zero ohms if there is continuity in the cable assembly.
  - c. Check continuity in both ends of the main cable assembly at pin #5.
  - d. If there is no continuity in the cable assembly at either pin, replace the cable assembly and retest. If there is continuity in the cable assembly at both pins and the relay resistor indicator is not lit, the console is inoperable and must be replaced.
5. Have your assistant step on the staircase (leave the console in the *ATTRACT* mode) while you check the field indicator light. It should be flickering. If it is and you still have a speed control problem, go to step #6.

If it is not flickering, ensure the following: the console cable is connected to the console; the console/main cable connection is secure; the connector at position J1 on the relay assembly circuit board is securely connected; that there is continuity in the cable assembly. To check for continuity:

- a. Unplug the connector at position J1 on the relay assembly circuit board. Disconnect the console cable from the back of the console. Set your multimeter to the continuity check mode; on most meters this will be the resistance or ohms setting.
- b. Place one lead of the multimeter on pin #2 at the console connector end of the console cable (refer to Wiring Diagram 1). Place the other lead on pin #2 at the end of the main cable you disconnected from the relay assembly circuit board. You will get a reading of near zero ohms if there is continuity in the cable assembly.
- c. If there is no continuity in the cable assembly, replace it and retest. If



## SPEED CONTROL PROBLEMS

there is continuity in the cable assembly and the field indicator light is still not flickering, contact the Customer Service Department for further assistance.

6. If the field indicator was flickering while your assistant was on the machine and you still have a problem with speed control, you need to test the alternator (refer to Wiring Diagram 3).
  - a. Disconnect the white wire (labeled positive output on the alternator) and the brown wire (labeled "Field" on the alternator). Use a jumper wire to jump the Field and positive output terminals of the alternator.
  - b. Have your assistant step onto the staircase. Does the staircase slow down? If it does not, you need to replace the alternator. If the staircase does slow down, contact the Customer Service Department for further assistance.
- C. Replace or exchange the alternator with another alternator you know is good and retest the machine.
- D. Test the load resistor as outlined in the "Load Resistor Test" section of this Manual.
- E. If the speed control problem still exists, contact the Customer Service Department for further assistance.

## LOAD RESISTOR TEST

The alternators are heavy-duty models designed to withstand the rigors of commercial use. One possible reason for repeated failure is an inoperable load resistor. To test the load resistor:

1. Unplug the AC power cord from the AC wall outlet.
2. Locate the load resistor mounted to the frame just under the staircase.
3. Disconnect one black wire from the resistor (refer to Wiring Diagram 3).
4. Set your multimeter for Rx 1 or the lowest available resistance range. If you have an analog multimeter, touch the two leads together and adjust the meter for a zero reading.
5. Place one lead on Tab A and one lead on Tab 5 of the relay assembly circuit board (refer to Wiring Diagram 2). You should get a reading of approximately 1.0 ohm or less.
6. Replace the load resistor if the reading is out of range and retest the new load resistor.
7. Reconnect the AC power cord and reinstall the right side cover.



## TROUBLESHOOTING THE DRIVE TRAIN

If you hear a grinding or clicking noise, or experience excessive vibration during exercise, or if the steps are not functioning properly, you probably have a problem in the drive train. Attempt to isolate the problem area by performing the following tests in precisely the order listed below. Refer to the "Parts Removal and Replacement" Section of this *Manual* for all disassembly and assembly instructions.

1. Unplug the power supply from the AC wall outlet and remove the side covers.



### WARNING

TO REDUCE THE RISK OF INJURY, DO NOT OPERATE THE MACHINE WHILE THE SIDE COVERS ARE REMOVED. DO NOT ROTATE THE STAIRS WHILE ANYONE'S HANDS ARE INSIDE THE MACHINE.

2. Check the condition and the tension level of the Poly-V belt. Replace the belt if it is excessively worn.
  - a. Adjust the tension level so that you can deflect either side of the belt 1/10" (0.25 cm) at the center between the alternator and the transmission pulleys (refer to Figure 14). Noise can be generated by a belt that is too tight or too loose.
  - b. If the noise is still present, remove the Poly-V belt and work the revolving staircase. Note: With the Poly-V belt removed, the staircase will rotate very quickly.
  - c. If the noise no longer exists, replace the alternator.
3. Check the condition of the alternator.
  - a. Remove the Poly-V belt.
  - b. Spin the alternator pulley with your fingers. It should spin freely and remain spinning for at least one and one-half revolutions. If it does not spin as it should, the bearings may be bad and the alternator should be replaced.
  - c. If the pulley does spin freely, check the alternator for noise, roughness, or the presence of black powder inside the alternator or near the outside of the case. If any of these conditions exist, the brushes may be bad and the alternator should be replaced.
  - d. Reconnect the Poly-V belt and adjust the belt tension.



## TROUBLESHOOTING THE DRIVE TRAIN

4. Check the drive chain mechanism. Rotate the stairs and look for chain links that do not flex as the chain travels over the sprockets. If the links are frozen or sticking, replace the chain.
5. Check the step chain assemblies.
  - a. Have your assistant slowly exercise on the machine. Observe the staircase. If the staircase moves to the left or right during exercise, ensure the set screws in the bearing adjusters are tight.
  - b. Rotate the stairs and look for chain links that do not flex as the chain travels over the sprockets. If the links are frozen or sticking, replace the chain.
6. Check the condition of the upper and lower sprocket assemblies. Replace the sprocket assembly if it is worn excessively, has broken teeth, or if it is bent.
7. Check the alignment of the upper and the lower sprocket assemblies. The outside face of the upper and lower sprockets should be 1-11/16" (4.3 cm) from the outside edge of the left frame rail. Loosen the nuts on the pillow block bearing collars and tighten or loosen the bearing adjuster set screws until the distance to both sprockets is correct. Tighten the pillow block bearing nuts and verify the distance.
8. Check the step assembly.
  - a. Rotate the steps and check the hinges, step shafts, washers, and bearings (refer to Figure 16) for wear, corrosion and lack of lubrication. Replace any worn parts.
  - b. Ensure the nuts at each step shaft end are tight.
9. Check the transmission.
  - a. Remove the drive chain and the Poly-V belt. Turn the transmission sprocket. It should turn freely without binding or releasing. If it does not, replace the transmission.
  - b. Check for a 19:1 gear ratio between the two shafts.

Place a mark from the transmission sprocket straight across to the transmission casing and a mark from the alternator pulley straight across to the alternator casing.



## TROUBLESHOOTING THE DRIVE TRAIN

Rotate the transmission sprocket through one full revolution while observing the alternator pulley. The alternator pulley should rotate through 19 full revolutions.

Replace the transmission if you detect roughness while rotating the sprocket or if the alternator pulley does not rotate 19 revolutions.

10. Reinstall all parts, ensuring the Poly-V belt is properly tensioned. Clean and lubricate the drive and step chains before reinstalling them.

## PARTS REMOVAL AND REPLACEMENT

### COVERS



There are five covers on the machine: two side covers, a back cover, a bottom cover, and a top cover. The side covers overlap the top cover. The side covers must be removed before the top cover. The side covers must also be removed before the bottom cover can be removed.

All covers are held in place with reusable plastic fasteners (refer to Figure 12 for their location). To remove the fasteners, slide either end of the fastener removal tool under the edge of the pin head (refer to Figure 13). The pin should not be removed. Pull the cover away from the frame. Do NOT use the fastener removal tool or any other sharp tool to pry out the fastener base because you may damage the covers.

To reinstall the fastener, insert the base of the fastener through the cover and into the frame. When the base is in place, push the pin in all the way to secure the fastener.

#### Side Covers

1. Remove the 14 fasteners on each side cover.
2. Pull the cover away from the frame.

#### Top Cover

1. Remove both side covers.
2. Lift the top cover away from the frame.
3. Set the top cover in place. Secure the side covers to complete reinstallation.

#### Back Cover

1. Remove the 10 fasteners and lift the back cover away from the frame.

## PARTS REMOVAL AND REPLACEMENT

2. Align the holes in the frame and the back cover. Secure the back cover with the 10 fasteners.

### Bottom Cover

1. Remove both side covers to gain access to the bottom cover fasteners.
2. Disconnect the DC power cable.
3. Remove the six fasteners and lift the bottom cover away from the frame.
4. Reinstall the bottom cover, then the two side covers. Remember to connect the DC power cable.

### CONSOLE

1. Locate the mounting knobs on the back of the console (refer to Figure 10).
2. Loosen and remove the four mounting knobs.
3. Unscrew the console cable from the back of the console.
4. To reinstall the console, connect the console cable to the back of the console.
5. Align the four console holes with the four holes on the console mount.
6. Insert and tighten a mounting knob into each hole.
7. There is no need to overtighten the knobs.

### POLY-V BELT



#### WARNING

THE POLY-V BELT MUST BE ADJUSTED SO THAT THE CENTER OF EITHER SIDE CAN BE DEFLECTED 1/10" (0.3 CM) FROM ITS CENTER LINE WITH FINGERTIP PRESSURE. A TIGHT BELT WILL CAUSE SLOW AND SLUGGISH OPERATION; A LOOSE BELT WILL CAUSE EXCESSIVE NOISE AND BELT WEAR.

1. Remove the left side cover.
2. Loosen the adjustment bolt that mounts the alternator to the slotted alternator brace.



## PARTS REMOVAL AND REPLACEMENT

3. Pivot the alternator forward to loosen the belt. Remove the Poly-V belt.
4. When reinstalling the Poly-V belt, pivot the alternator forward or back as necessary to allow 1/10" (0.3 cm) of play on either side of the belt (refer to Figure 14).
5. Tighten the adjustment bolt and verify the Poly-V belt tension.

### DRIVE CHAIN

1. Remove the left side cover.
2. Remove the retaining clip and retaining plate from the drive chain master link. Do not remove the master link from the drive chain yet.
3. Push up on the idler arm with one hand to relieve the tension on the drive chain (refer to Figure 15). Remove the master link from one end of the drive chain and remove the drive chain from the sprockets.
4. Reinstall the drive chain by reversing the steps.

### STEP ASSEMBLY

1. Remove the right and the left side covers.
2. Rotate the stairs until the step you want to remove is positioned in the middle of the staircase.
3. Loosen and remove the nut from one end of the step shaft on both the upper and the lower hinges of that step (refer to Figure 16). You may be required to place another 5/16"-18 nut on the opposite end of the step shaft to remove the nut.
4. Remove the bearing and the washer from each step shaft.
5. Grasp the opposite step retaining nut with pliers or locking pliers. Pull the step shaft out of the upper and lower step hinges. Be careful to not lose the washer located between the step and the modified link.
6. Reinstall the step by reversing the procedures.



## PARTS REMOVAL AND REPLACEMENT

### STEP CHAIN ASSEMBLY

1. Remove the right and the left side covers.
2. Rotate the stairs to position the step chain master link on the lower span of the chain (refer to Figure 17).
3. Remove the master link.
4. Using the old master link, connect the new chain assembly to the lower half of the old chain assembly.
5. Remove the nut from the step shaft above the master link (refer to Figure 16). You may be required to place another 5/16"-18 nut on the opposite end of the step shaft to remove the nut.
6. Remove the bearing, outer step shaft washer and the modified link of the old step chain assembly from the step shaft.
7. Place the modified link of the new step chain assembly on the step shaft. Reinstall the outer step shaft washer, bearing and nut.
8. Rotate the steps until the next step shaft is in approximately the same place as the previous step shaft.
9. Repeat steps 6-8 until the new chain assembly is installed on the remaining step shafts.
10. Remove the master link connecting the old chain with the new chain.
11. Connect the new chain assembly together with the master link. It may be necessary to reduce the chain tension to install the master link. This step is accomplished by:

Count and write down the number of exposed threads on the top bearing adjuster set screw for a reference when you reassemble the parts (refer to Figure 17).

Loosen the nuts on the pillow block bearing housing.

Loosen the bearing adjustment set screw until the chain tension level is relieved to a point where the master link may be reconnected.





## PARTS REMOVAL AND REPLACEMENT

Tighten the adjustment screw until the same number of threads are exposed.

Tighten the nuts on the pillow block bearing housing.

12. You should consider replacing the opposite step chain so that both chains will wear equally.
13. Reassemble the machine in reverse order.

### UPPER (AND LOWER) SPROCKET ASSEMBLY

1. Remove the right and left side covers.
2. Remove all of the steps.
3. Remove the drive chain if you are removing the upper sprocket assembly.
4. Remove the right and left step chain assemblies.
5. Count and write down the number of exposed threads on the bearing adjuster set screws on both sides of the machine for a reference when you reassemble the parts (refer to Figure 17).
6. Loosen the adjustment screws until the tips of the screws are flush with the inside face of the bearing adjusters.
7. Have an assistant support the sprocket assembly. Loosen and remove the nuts on the pillow block bearing housing.
8. Remove the sprocket assembly from the frame.
9. Loosen the two set screws on both of the pillow block bearing collars and remove the pillow block bearings from the sprocket axle.
10. To reinstall the sprocket assembly:

Slide the pillow block bearings on both ends of the sprocket axle. Do not tighten the set screw on the pillow block bearing collars yet.

Place the bearing adjusters and the sprocket assembly onto the frame and start the pillow block bearing housing nuts onto the frame.

## PARTS REMOVAL AND REPLACEMENT

Slide the sprocket assembly toward the front of the machine while tightening pillow block bearing housing nuts.

Align the sprocket assembly. The outside face of the left sprocket should be 1-11/16" (4.3 cm) from the outside edge of the left frame rail. Move the sprocket axle within the pillow block bearing collar as needed to get the correct distance.

When the distance is correct, tighten the pillow block bearing collar set screw on the left and right side of the machine.

Loosen the pillow block bearing housing nuts slightly. Tighten the bearing adjuster set screws until the exact number of threads are exposed (refer to your notes taken earlier). Tighten the pillow block bearing housing nuts.

Check the alignment of the other sprocket at this time. If the distance from the outside edge of the left frame rail to the outside face of the sprocket is not 1-11/16" (4.3 cm), loosen the set screws on the left and right side pillow block bearing collars and adjust the axle. Tighten the pillow block bearing collar set screws on the machine.

11. Complete the reassembly of the machine by performing steps 1-4 in reverse order.

### CABLE ASSEMBLY

1. Remove the right side cover.
2. Remove the console and unscrew the console cable from the back of the console. Unplug the plastic connectors at the console cable: main cable junction.
3. Hold the console connector and pull the console cable up and out of the handrails.
4. Reinstall the console cable by pushing the white plastic connector end down through the handrails. Do not connect the console and the main cables.
5. Remove the main cable from the wire saddles (refer to Wiring Diagram 1).
6. Unplug the white plastic connector labeled J1 on the relay assembly circuit board (refer to Wiring Diagram 2).
7. Cut the four tyrap on the vertical support.



## **PARTS REMOVAL AND REPLACEMENT**

8. Remove the main cable from the frame.
9. To reinstall, place the main cable into the wire saddles. Reattach the cable to the vertical support with four tytraps.
10. Plug the white plastic connector of the main cable into the relay assembly circuit board at the spot labeled J1.
11. Screw the console cable into the receptacle in the back of the console. Reattach the console to the handrail mount. Plug the connectors together at the main cable: console cable junction.
12. Reinstall the right side cover. Reconnect the DC power cable.

## **TRANSMISSION ASSEMBLY**

1. Remove the left side cover.
2. Remove the step positioned in the middle of the staircase.
3. Remove the drive chain.
4. Remove the Poly-V belt. Inspect the belt for wear. Replace the belt if it is cracked, worn, torn, or cut.
5. Remove the transmission bracket by loosening and removing the mounting hardware on the alternator and the transmission (refer to Figure 18).
6. Remove the transmission brace by loosening and removing the mounting hardware from the transmission and the frame.
7. Support the transmission while loosening and removing the four transmission mounting bolts. Remove the transmission and rubber pad from the frame.
8. Reinstall the transmission by reversing the removal procedures.
9. Ensure the Poly-V belt is tensioned according to the procedures outlined in the "Poly-V Belt" section of this Manual.



## PARTS REMOVAL AND REPLACEMENT

### ALTERNATOR ASSEMBLY

1. Remove the right and left side covers.
2. Remove the step positioned in the middle of the staircase .
3. Remove the wiring from the alternator terminals, noting the origin and color of the wires removed from each terminal.
4. Remove the Poly-V belt. Inspect the belt for wear. Replace the belt if it is cracked, worn, torn, or cut.
5. Remove the alternator adjustment bolt (refer to Figure 18).
6. Remove the nut, bolt and mounting hardware from the alternator bracket. Remove the alternator from the frame .
7. Reinstall the alternator by reversing the removal procedures. Be sure to verify the wiring connections (refer to Wiring Diagram 3).
8. Ensure the POLY-V belt is tensioned according to the procedures outlined in the "Poly-V Belt" section of this Manual.

### RELAY/RESISTOR ASSEMBLY

1. Remove the left side cover.
2. Remove the step positioned in the middle of the staircase .
3. Remove the wiring from the alternator terminals, noting the origin and color of the wires that are removed from each terminal.
4. Unplug the main cable connector from the J1 position on the relay circuit board (refer to Wiring Diagram 2).
5. Unplug the power connector from the J2 position on the relay circuit board.
6. Loosen and remove the four mounting bolts and remove the relay/resistor assembly from the frame (refer to Wiring Diagram 1).
7. Reinstall the relay/resistor assembly in the reverse order. Verify the wiring connections before attaching the side cover (refer to Wiring Diagram 3).

## GROUNDING INSTRUCTIONS

The machine must be grounded. If it should malfunction or break down, grounding provides the path of least resistance for the electric current, thereby reducing the risk of electric shock. This machine is equipped with a cord having an equipment-grounding conductor and a grounding plug that looks like the plug illustrated in sketch A in Figure 9 below. International machines may vary. It must be plugged into an appropriate outlet that is properly installed and grounded in accordance with all local codes and ordinances.

**DANGER**  
IMPROPER CONNECTION OF THE EQUIPMENT-GROUNDING CONNECTOR CAN RESULT IN THE RISK OF ELECTRIC SHOCK. CHECK WITH A QUALIFIED ELECTRICIAN OR SERVICE PERSON IF YOU ARE IN DOUBT AS TO WHETHER THE MACHINE IS PROPERLY GROUNDING. DO NOT MODIFY THE PLUG PROVIDED WITH THIS MACHINE. IF IT WILL NOT FIT THE AVAILABLE OUTLET, HAVE A PROPER OUTLET INSTALLED BY A QUALIFIED ELECTRICIAN.

A temporary adapter that looks like the adapter illustrated in sketches Band C may be used to connect this plug to a two-prong receptacle as shown in sketch B if a properly grounded outlet is not available. The temporary adapter should be used only until a properly grounded outlet (sketch A) can be installed by a qualified electrician. The green colored lug extending from the adapter must be connected to a permanent ground such as a properly grounded outlet box cover. Whenever an adapter is used, it must be held in place by a metal screw.

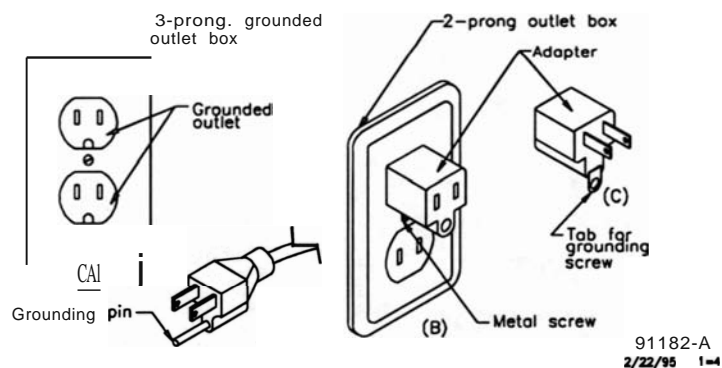

Figure 9: Grounding System



## FCC COMPLIANCE

This equipment has been tested and found to comply with the limits for a Class A digital device, pursuant to Part 15 of the FCC rules. These limits are designed to provide reasonable protection against harmful interference when the equipment is operated in a commercial environment. This equipment generates, uses, and can radiate radio frequency energy and, if not installed and used in accordance with the instruction manual, may cause harmful interference to radio communications. Operation of equipment in a residential area may cause harmful interference in which case the user will be required to correct the interference at his own expense.



### **WARNING**

CHANGES OR MODIFICATIONS TO EQUIPMENT NOT EXPRESSLY APPROVED BY STAIRMASTER® SPORTS/MEDICAL PRODUCTS, INC. COULD VOID THE USER'S AUTHORITY TO OPERATE THIS EQUIPMENT.

## CANADIAN DOC CLASS A COMPLIANCE

This digital apparatus does not exceed the Class A limits for radio emissions from digital apparatus set out in the radio interference regulations of the Canadian Department of Communications.

La present appareil numerique ne depasse pas les limites etablies pour les bruits radioelectriques applicables aux appareils numeriques de la Class A prescrites dans les reglements sur le brouillage radioelectrique edicte par le Ministere des Communications du Canada .



## HOW TO ORDER PARTS

If you need assistance, please have both the serial number of your machine and the date of purchase available when you contact the appropriate StairMaster® Sports/Medical Products, Inc. *office* listed below.

### OFFICES IN THE UNITED STATES

CORPORATE HEADQUARTERS  
12421 Willows Road NE, Suite 100  
Kirkland, WA 98034  
(800) 635-2936 or (206) 823-1825  
FAX: (206) 823-9490

CUSTOMER SERVICE  
12421 Willows Road NE, Suite 100  
Kirkland, WA 98034  
(800) 331-3578  
FAX: (206) 814-0601

### INTERNATIONAL OFFICES AND DISTRIBUTORS

INTERNATIONAL DIVISION  
(206) 823-1825  
FAX: (206) 820-7505

CANADA: TRC SPORTS/MEDICAL  
PRODUCTS  
(800) 668-4857  
(905) 712-2719  
FAX: (905) 712-3722

EUROPE: HEADQUARTERS  
41-91-827-3801  
FAX: 41-91-827-8902

JAPAN: SENOH CORPORATION  
81-3-5479-6711  
FAX: 81-3-5479-6703

GERMANY: HEADQUARTERS  
49-2204/610-27  
FAX: 49-2204/628-90

AUSTRALIA: THE FITNESS  
GENERATION PTY LTD  
61-3/800-2122  
FAX: 61-3/800-2722

U.K.: HEADQUARTERS  
44-1908/221-323  
FAX: 44-1908/223-162

SWEDEN/NORWAY: NORDIC GYM  
PRODUCTION  
46-278/242-10  
FAX: 46-278/159-66

FRANCE/BELGIUM/HOLLAND:  
MONDIAL S.P.R.L.  
32-82/226775  
FAX: 32-82/226854

COUNTRIES NOT LISTED  
(206) 823-1825  
FAX: (206) 820-7505

FIGURES

Figure 10: Installation Diagram

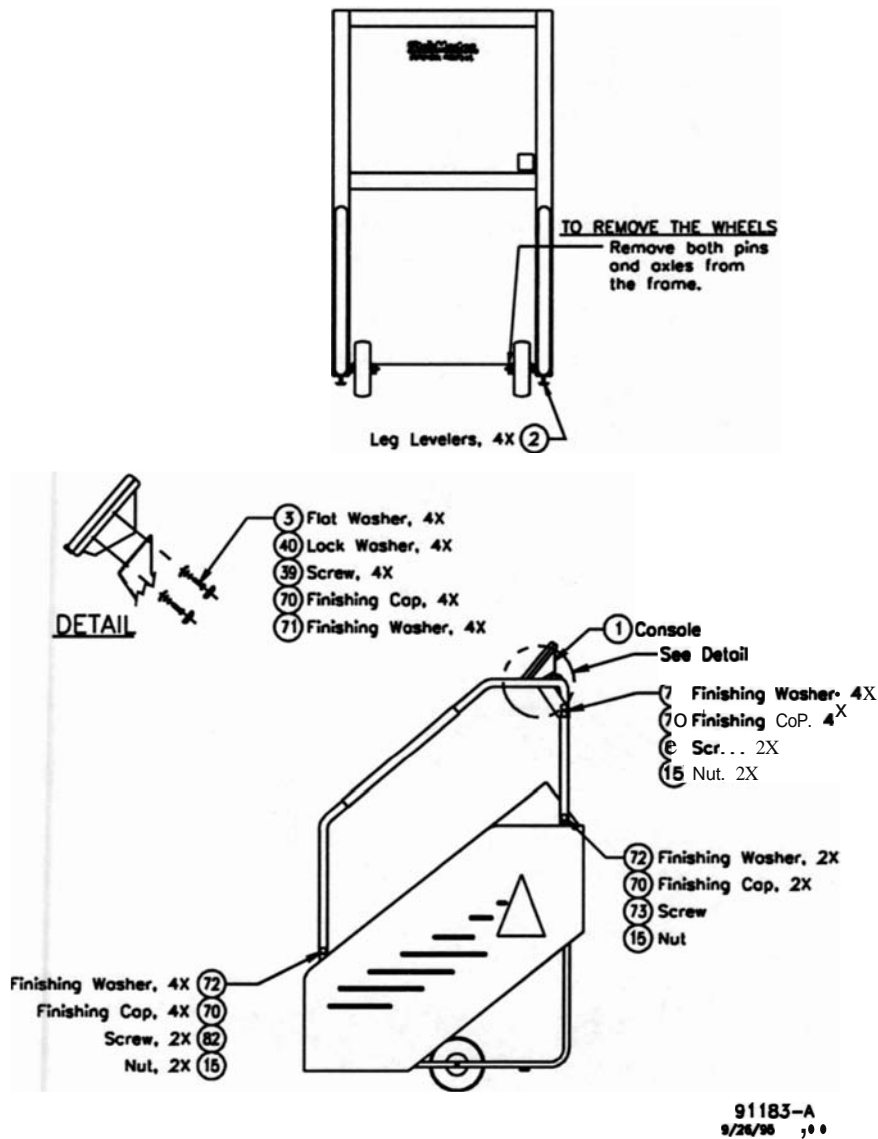



**FIGURES**

**Figure 11: Parts Needing Periodic Lubrication**

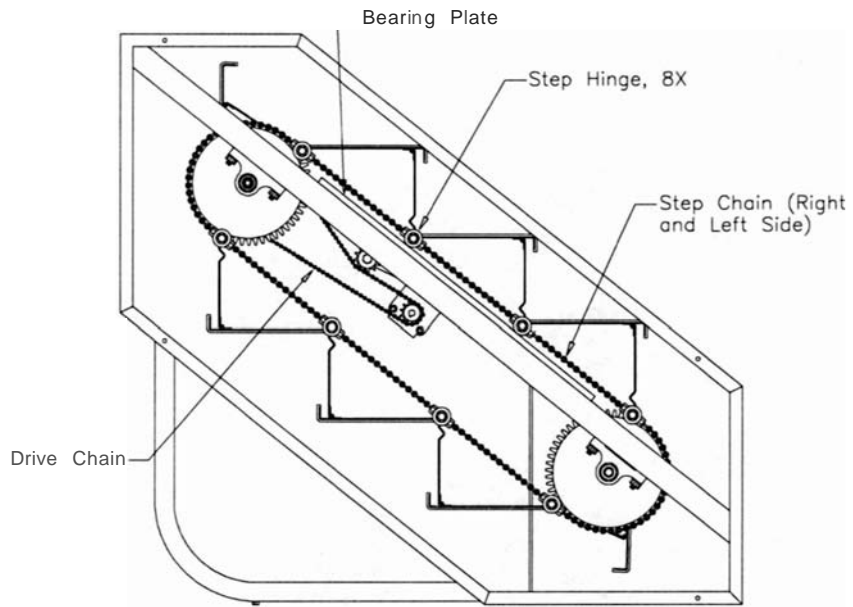

9 11 84-A  
4/18/95 I=20

FIGURES

Figure 12: Side Cover and Handrail Assemblies

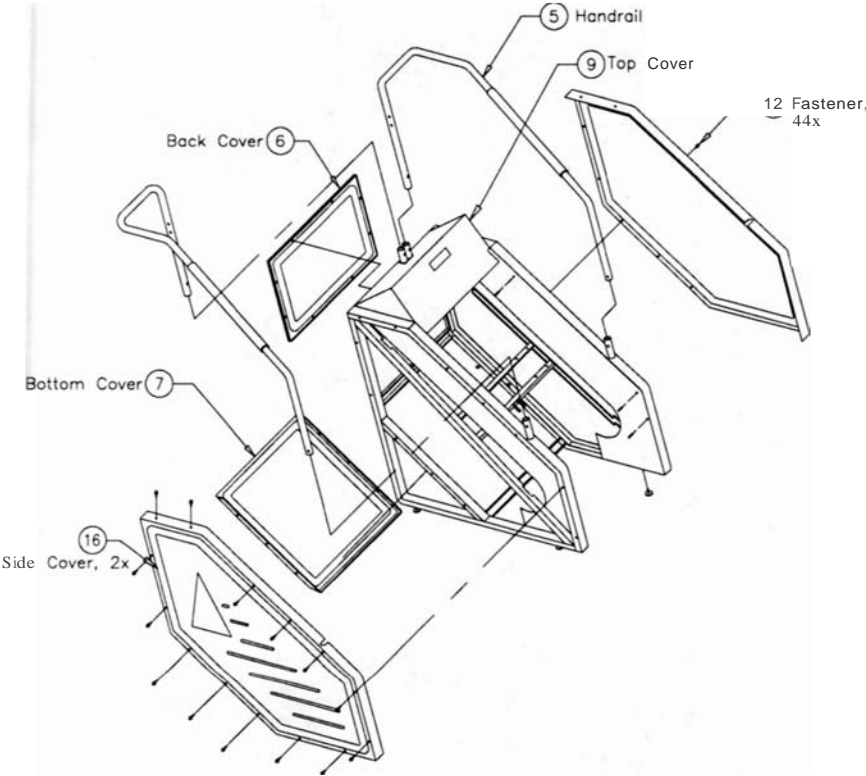

91185-A  
9/06/95 1-40

FIGURES

Figure 13: Cover Fasteners

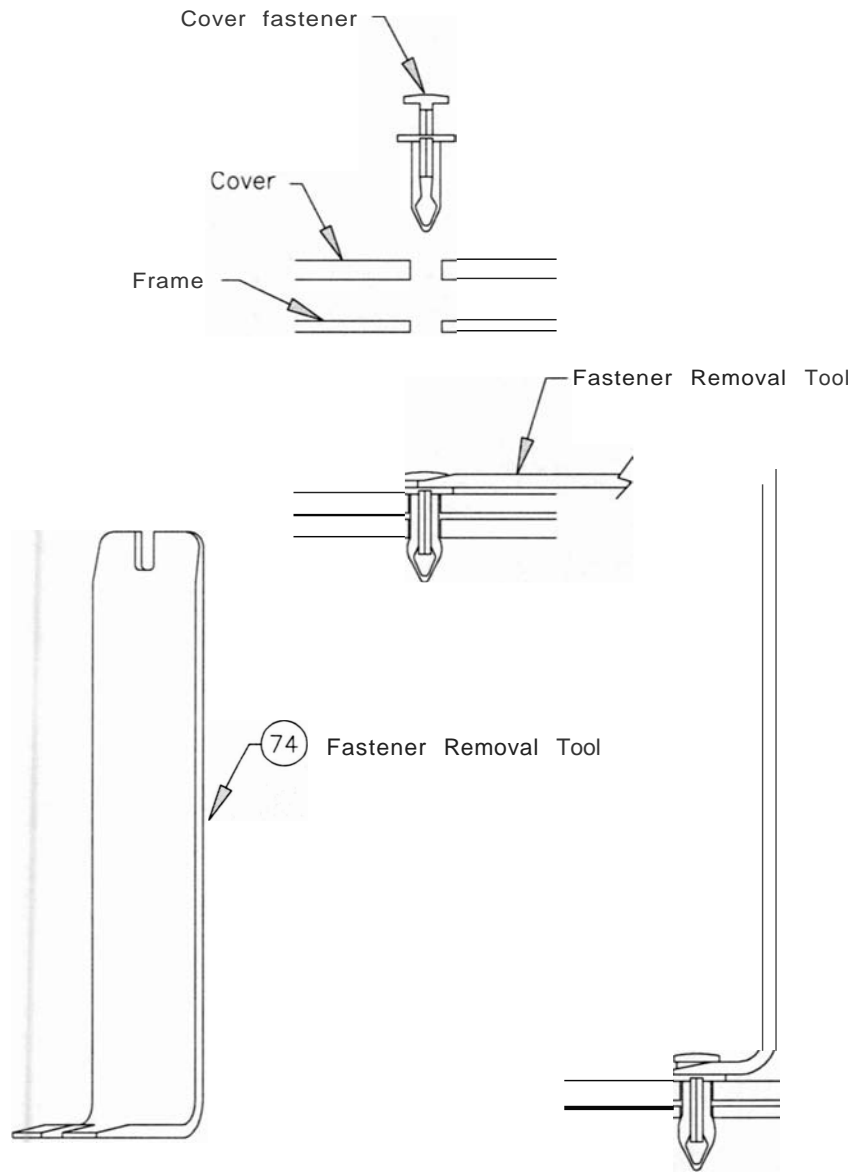

9 1261-A  
9/29/94 1=2

FIGURES

Figure 14: Poly-V Belt Tension

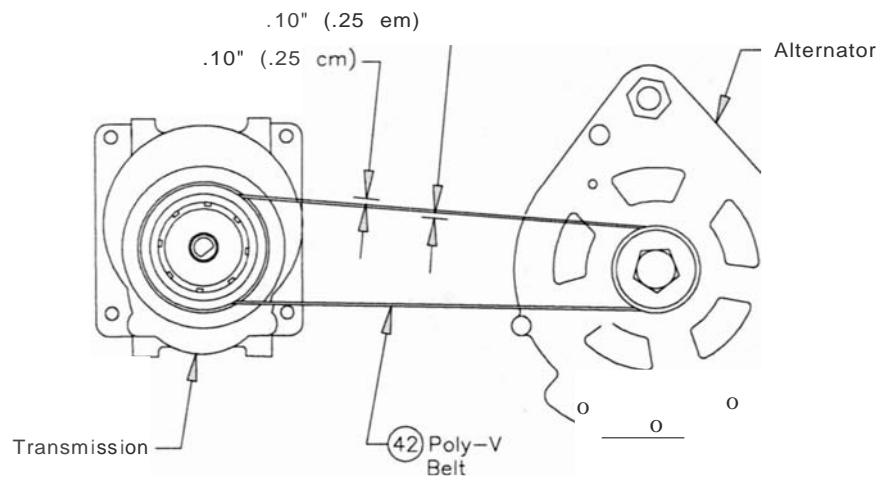

91186-A  
2/02/95 1=4

FIGURES

Figure 15: Drive Chain Assembly

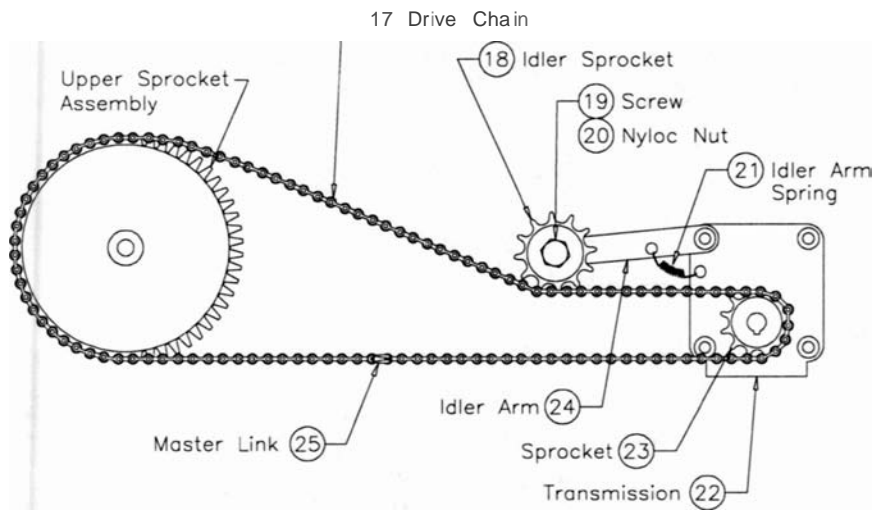

911 87-A  
4/26/95 1=14

FIGURES

Figure 16: Step Assembly

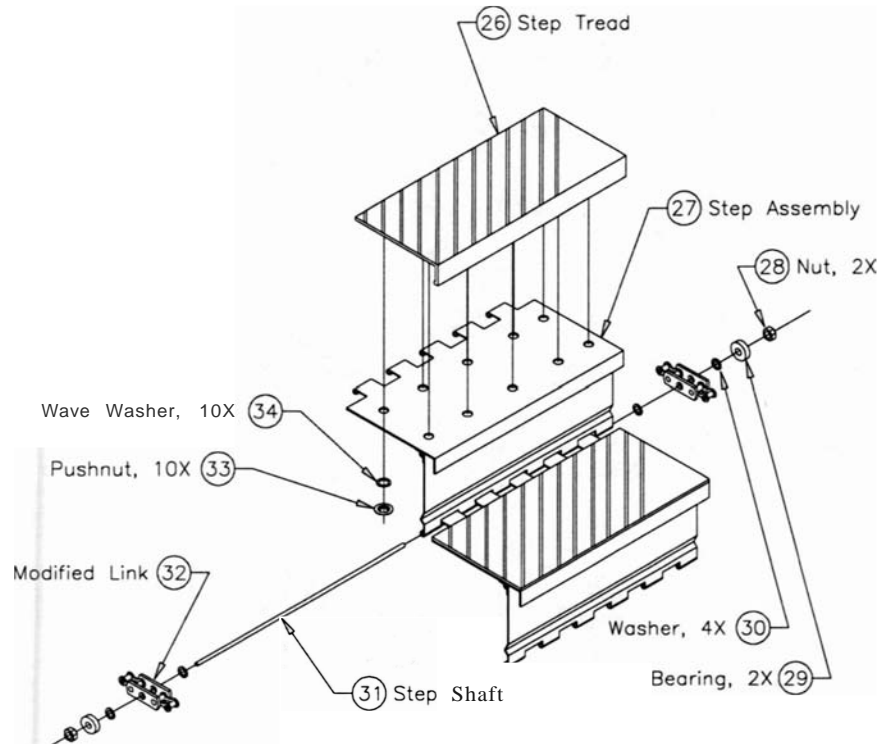

91188-A  
4/18/95 1-20

# FIGURES

Figure 17: Step Chain and Sprocket Assemblies

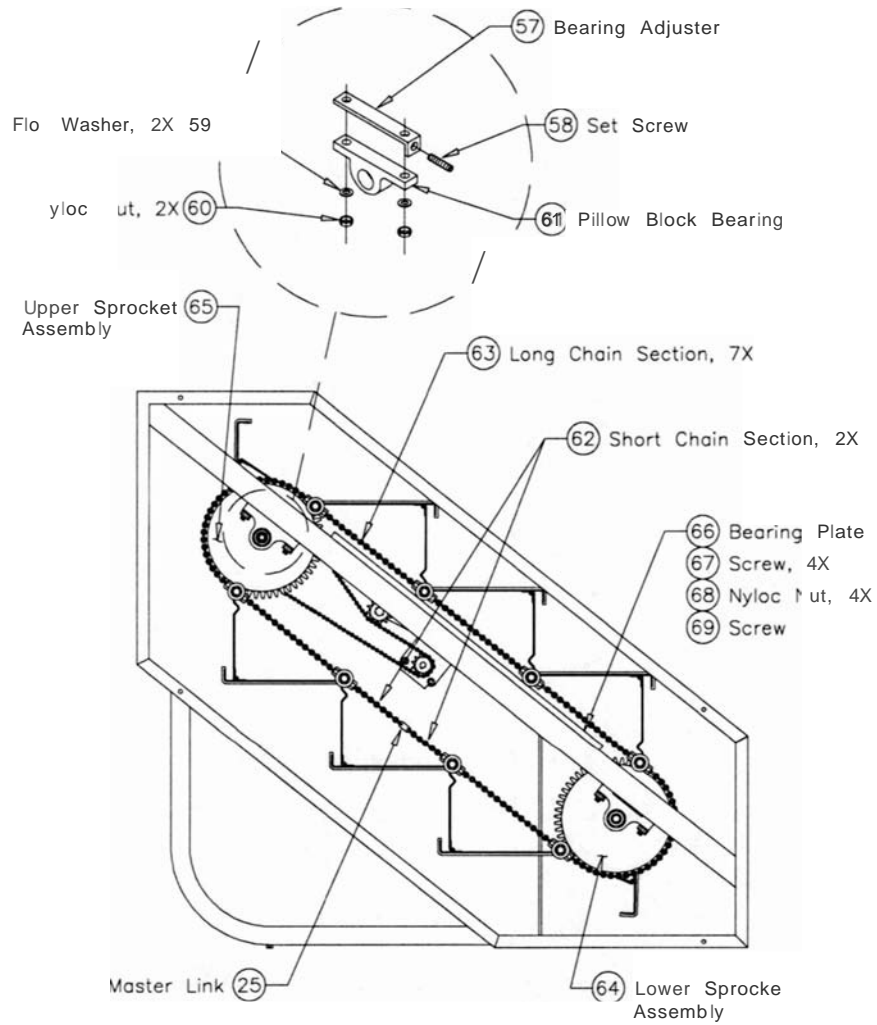

91189-A  
5/01/95 1=20

FIGURES

Figure 18: Transmission and Alternator Assemblies

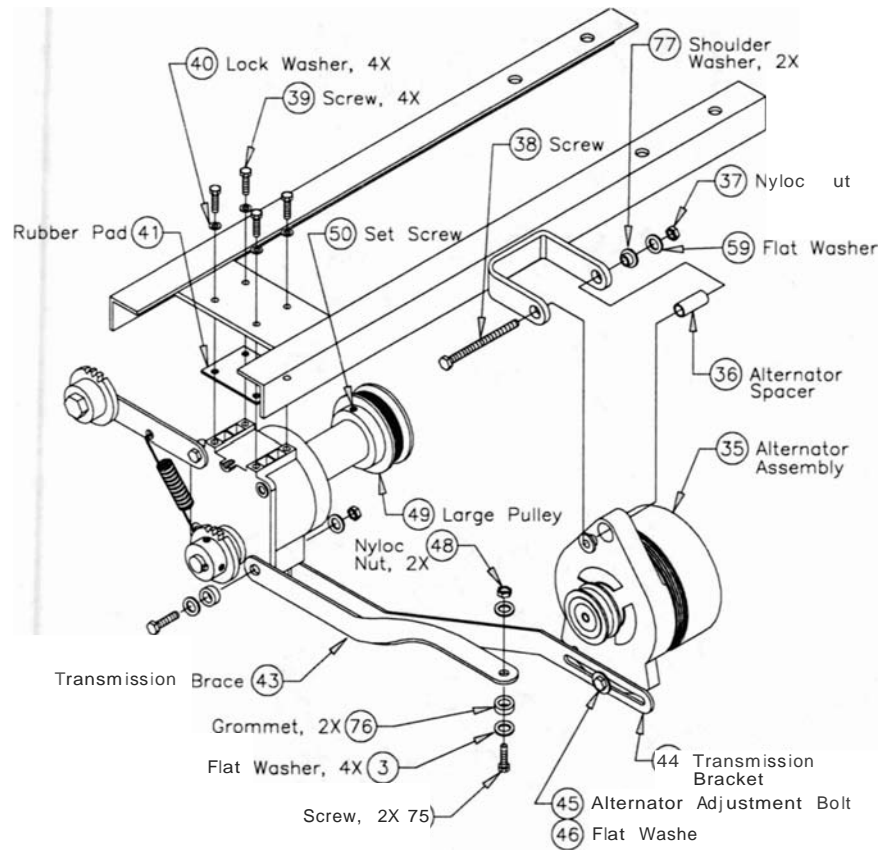

91191-A  
9/06/95 1=16



# WIRING DIAGRAMS

## Wiring Diagram 1

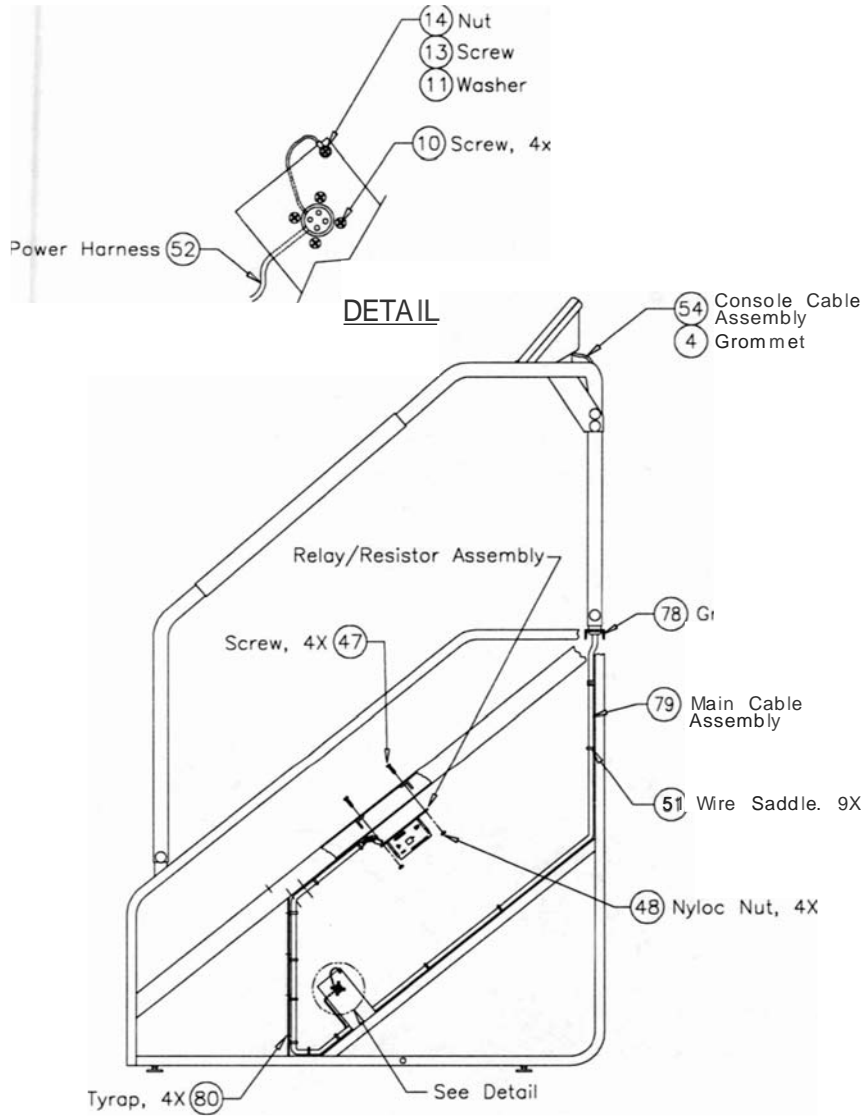

9 11 92-A  
9/06/95 I=20

# WIRING DIAGRAMS

## Wiring Diagram 2

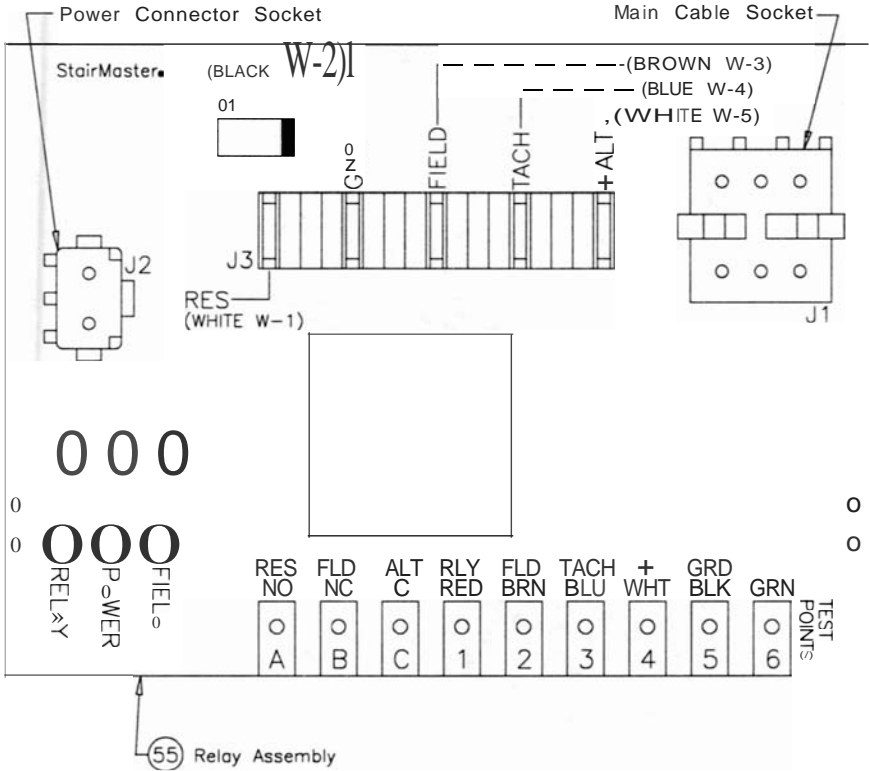

91260-A  
4/18/95 1=1

# WIRING DIAGRAMS

## Wiring Diagram 3

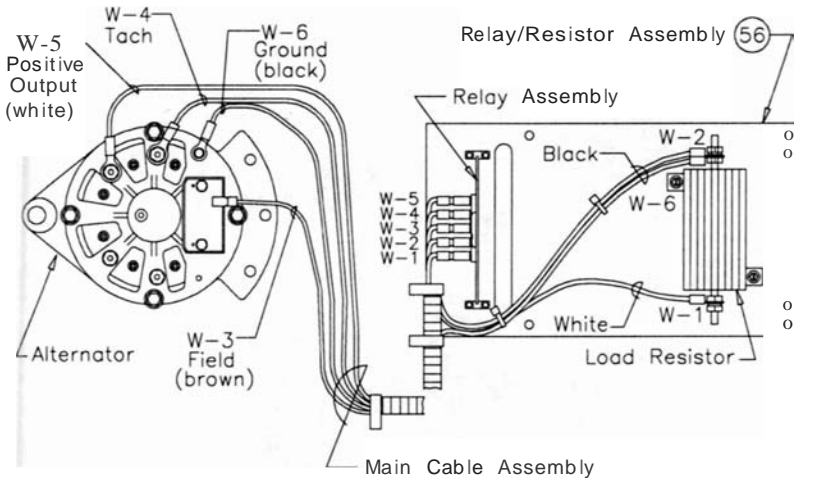

9 1193-A  
4/18/95 1-12

## KEY TO FIGURES AND WIRING DIAGRAMS

Q Number	Description	Part Number
1	Console assembly	24742 -
2	Leg levelers	20017
3	Flat washer, 1/4"	22038
4	Grommet	24663
5	Handrail, right	22946-03
	Handrail, left	22947-03 -
6	Back panel	21304
7	Bottom panel	21305 -
9	Top panel	21308 -
10	Screw, #6 x 3/8	24208
11	Internal tooth washer, #8	22109
12	Rivet	22086
13	Screw, #8 - 32 x 3/8	22134
14	Nut, #8 - 32	22110
15	Nut, 3/8 - 16, Low profile	24643
16	Side panel assembly, left (with decal)	24298 -
	Side panel assembly, right (with decal)	24299 -
17	Drive chain, #40 x 41 .5"	23257
18	Idler sorocket	20007
19	Screw, 1/2 - 13 x 2"	22043
20	Nyloc nut, 1/2 - 13	22042
21	Idler arm spring	20054
22	Transmission	20001
23	12T sprocket	23427
24	Idler arm	20693
25	#40 Master link	20157
26	Step tread	20541
27	Step assembly	10378-03
28	Nut 5/16 - 24	22063
29	Bearing	23082
30	Flat washer, 5/16"	22128
31	Step shaft	20762
32	Modified link	20548
33	Pushnut	20508
34	Wave washer	20528
35	Alternator assembly	21164
36	Alternator spacer	20114
37	Nyloc nut 1/2 - 13	22092
38	Screw, 1/2 - 13 x 3 3/4"	22090 -
39	Screw 1/4 - 20 x .63"	22028
40	Lock washer, 1/4"	22027

## KEY TO FIGURES AND WIRING DIAGRAMS

10 Number	Description	Part Number
41	Rubber pad	20808
42	Poly-V belt	20202
43	Transmission brace	10059
44	Transmission bracket	10860 -
45	Screw, 5/16 - 18 x 1 1/4"	22146
46	Flat washer, 5/16"	22075
47	Screw, 1/4 - 20 x 1.0"	22026
48	Nyloc nut, 1/4 - 20	22036
49	Large pulley	20208
50	Set screw	22037
51	Wire saddle	23792
52 ~	Main power harness assembly	22957
54 -	Console cable assembly	22428
55 =	Relay assembly	23544 -
56	Relay/resistor assembly	23546
57	Bearing adjuster	10037 -
58	Screw, 3/8 - 16 x 1"	22039
59	Flat washer, 3/8"	22030
60	Nyloc nut 3/8 - 16	22029
61	Pillow block bearing	20101 -
62	Chain section, #40 x 5 1/2"	20532
63	Chain section, #40 x 11 1/2"	20531
64	Lower sprocket assembly	10205-03
65	Upper sprocket assembly	23424-03
66	Bearing plate	20682
67	Screw, 5/16 - 18 x 1"	22071
68	Nyloc nut, 5/16 - 18	22032
69	Screw, 5/16 - 24 x 3/8"	22072
70	Finishing Cap	22323
71	Console mounting knob	24677
72	Finishing washer, 3/8"	22213
73	Screw 3/8 - 16 x 3.25	22097
74	Fastener removal tool	23853
75	Screw, 1/4 - 20 x 1.25	22164
76	Grommet, 1/4" 10	22435
77	Shoulder washer, .38 10	22191
78	Grommet, 7/8"	15034
79 =	Main cable assembly	22956
80	Tyrap	20473
81	Screw 3/8 - 16 x 3.5	22937



## KEY TO FIGURES AND WIRING DIAGRAMS

ID Number	Description	Part Number
82	Screw, 3/8 - 16 x 1.75	24640
	Power Supply, PS-7	24683
	Power Supply, IPS-3	14072 -
	Touch-up kit	21211 -



# STP MILL® 7000

## OWNER'S MANUAL



**StairMaster**  
THE RESULTS YOU WANT™



Printed in the United States.  
© 1996, 2001 StairMaster® Health & Fitness Products, Inc.  
All rights reserved.

**Corporate Headquarters**  
12421 Willows Road N.E., Suite 100  
Kirkland, WA 98034

(800) 635-2936  
(425) 823-1825  
Fax (425) 823-9490  
[www.stairmaster.com](http://www.stairmaster.com)

**StairMaster**



**P/N 22440 - B**

© 1996, 2001 StairMaster Health & Fitness Products, Inc. StairMaster and Stepmill are registered trademarks or trademarks of StairMaster Health & Fitness Products, Inc. in the United States and/or other countries. All other trademarks are trademarks of their respective companies. StairMaster is a Rutledge Capital company.





## **A FEW REASONS WHY MORE HEALTH AND FITNESS FACILITIES CHOOSE STAIRMASTER® EQUIPMENT**

### **OUTSTANDING QUALITY**

Equipment you can depend upon, week after week, for heavy commercial use – instead of a sign that says "out of order."

### **EXCEPTIONAL PERFORMANCE**

Generates exceptional customer satisfaction – allowing you to retain existing club members and attract new ones.

### **IMMEDIATE CUSTOMER RECOGNITION**

An excellent first impression is critical to attracting new club members to your facility. The StairMaster name on your equipment reinforces your club's reputation for quality and effectiveness.

### **NATIONAL SALES SUPPORT**

StairMaster is one of the few organizations that maintains its own fully staffed national sales organization. These individuals will bend over backwards to make sure you are satisfied.

### **FACTORY-TRAINED SERVICE NETWORK**

The StairMaster service staff is on call to quickly address any product concerns. Service is just a toll-free call away.

### **AFFORDABLE LEASING PROGRAM**

We help you make the most of your money, with several types of leasing programs available.

### **FACILITY PLANNING**

Cordless units. Space-efficient designs. Exciting facility layout plans. Our staff works closely with you to maximize the equipment layout of your club or fitness area.

### **MARKETING SUPPORT**

Lots of sizzle – with StairMaster product catalogs, posters, promotional kits, and seasonal promotions.

## A FULL LINE OF EXCEPTIONAL PRODUCTS

### STAIRCLIMBERS

*The Best in the Industry*

Our popular FreeClimber® stairclimber line now offers you 5 different models to choose from. These models include the new fully featured FreeClimber 4600 PT and the cordless FreeClimber 4600 CL, along with the FreeClimber 4400 PT and the cordless FreeClimber 4400 CL with Polar® Heart Rate Monitor, and the cost-efficient FreeClimber 4200 PT – all designed especially for health clubs.

Other StairMaster® stairclimbers include the Stepmill® 7000 PT – for the most challenging stairclimbing workout – as well as the legendary StairMaster 4000 PT®.

### ELLIPTICAL STRIDING SYSTEMS

*The New StairMaster FreeRunner*

Introducing the StairMaster FreeRunner™ 5400 ESS – a revolutionary new design that allows you to vary your stride length from 10" to 40." Not only does this unique VSL feature accommodate all users, it also provides enhanced lower-body conditioning – with greater involvement of the glutes, quadriceps, and hamstrings.

For total-body conditioning, club members will love the fact they can use the handles on the StairMaster FreeRunner 5400 for an effective upper-body workout. These handles can also be easily disengaged to rest on the side of the machine.



# A FULL LINE OF EXCEPTIONAL PRODUCTS

## TREADMILLS

*The Highest Quality*

In response to many requests we received from our customers for a high quality treadmill, StairMaster® has selected the Quinton® treadmill as a new addition to our product line – with four different models to choose from – the ClubTrack® 510, the ClubTrack® 510 Plus, the ClubTrack® 612 and the ClubTrack® 612 Plus. Only Quinton could match the StairMaster reputation for maximum performance, durability, and product safety.

## STRATUS EXERCISE BIKES

*New Models & Prices*

At last – a cordless line of variable resistance exercise bikes that not only provide the exciting workout programs that StairMaster is famous for, but are designed with such uncompromising attention to every biomechanical detail, they offer you extraordinary safety and comfort.

Introducing Stratus exercise bikes – a new cordless variable resistance line from StairMaster – that are available with either an upright or recumbent seat. Just like StairMaster's legendary stairclimbers, Stratus exercise bikes are very different from other models – simply because they feel so good to use.

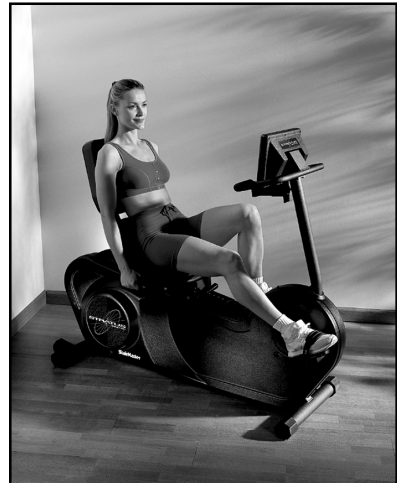

## A FULL LINE OF EXCEPTIONAL PRODUCTS

### **CROSSROBICS® 1650 LE**

*The Ultimate Exercise Machine*

The StairMaster® Crossrobics product is an innovative machine that combines aerobic exercise with a weight stack for strength conditioning. Available only from StairMaster, the Crossrobics machine provides the ultimate workout.

The Crossrobics 1650 LE features an easy-to-operate, first-time user option and a quick-start feature.

### **STAIRMASTER STRENGTH SYSTEMS**

*Feel the Difference*

Club members will feel the difference the first time they use StairMaster® strength equipment – designed to work the way your body works.

Consisting of the Gravitron® 2000 AT and the new Arcuate® and Linear™ lines, StairMaster offers you 17 different strength training products to choose from. To ensure the highest quality, all StairMaster strength equipment is now manufactured at our own factory in Tulsa, Oklahoma.

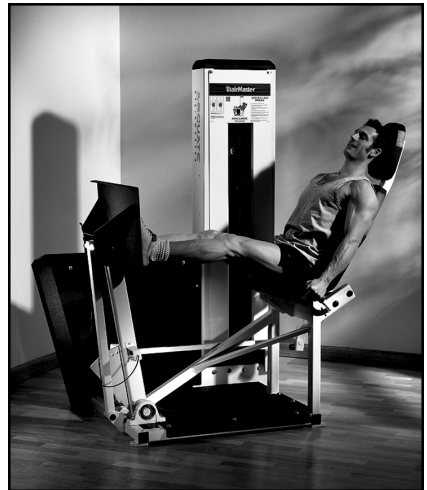



## WARRANTY

This is to certify that the StairMaster® Stepmill® 7000 PT exercise system is warranted by StairMaster Health & Fitness Products, Inc. to be free of all defects in materials and workmanship. This warranty does not apply to any defect caused by negligence, misuse, accident, alteration, improper maintenance, or an “act of God”. This warranty is non-transferable from the original owner.

If, within three years from the date of purchase, any part of the StairMaster Stepmill exercise system should fail to operate properly (except any accessories), contact our Customer Service Department to report the problem. When calling, please be prepared to provide the customer service representative with the following information:

- Your name, customer number, shipping address, and telephone number
- The model and serial number of the inoperable machine
- The date(s) of purchase for the inoperable machine(s)
- Your billing address

This information will ensure that you are the only one ordering parts under your warranty protection. If warranty replacement parts are shipped to you, you may be required to return the inoperable part. To facilitate this process, the following policy has been established:

- Please call our Customer Service Department to receive a return materials authorization prior to shipment.
- StairMaster Health & Fitness Products, Inc. will incur all freight charges for warranty parts ordered for a machine that is less than 45 days old. The parts will be shipped to you via an overnight courier.\*
- You are responsible for freight charges on warranty parts for machines that are more than 45 days old. You will not be responsible for the return shipment of the inoperable parts.
- Some inoperable warranty parts must be promptly returned to our Customer Service Department. We will pay the shipping cost for the inoperable warranty parts. Detailed instructions are included with each warranty replacement part.

StairMaster Health & Fitness Products, Inc. neither makes, assumes nor authorizes any representative or other person to make or assume for us, any other warranty whatsoever, whether expressed or implied, in connection with the sale, service, or shipment of our products. We reserve the right to make changes and improvements in our products without incurring any obligation to similarly alter products previously purchased. In order to maintain your product warranty and to ensure the safe and efficient operation of your machine, only authorized replacement parts can be used. This warranty is void if parts other than those provided by StairMaster Health & Fitness Products, Inc. are used.

\* Note: Aerosol products cannot be transported via air.



## PREFACE

The StairMaster® Stepmill® 7000 PT exercise system is a safe, functional, and effective exercise modality for developing aerobic fitness and increasing the strength of the major muscle groups of the lower body. It is designed for use by individuals of all ages and fitness levels. Your purchase of this machine is a positive affirmation of your commitment to use the best available methods for enhancing your functional fitness capabilities. In order to derive optimal benefits from your machine, you should read this manual thoroughly and adhere closely to the instructions.

### WHAT IS IN THIS MANUAL?

Following the information on installation and a brief explanation of how the Stepmill 7000 PT exercise system works, this manual contains two major sections. The first section provides an explanation of how the machine should be used to achieve maximum results. The second section offers instructions and advice on how to properly maintain your machine. The “Appendix” contains additional information for the owner.

Throughout this Manual, whenever you are required to enter information into the console, the console keypad keystrokes are enclosed in [ ]. The names of the buttons and special console operational modes are shown in capital letters. For example, your machine is ready for use when the console is in the ATTRACT mode. You are then required to press the [MANUAL] button to start the MANUAL exercise program.

### WHAT IS THE STAIRMASTER STEPMILL 7000 PT EXERCISE SYSTEM?

The StairMaster Stepmill 7000 PT exercise system is a vertical climbing machine with a rotating staircase which provides an aerobic workout equivalent to climbing stairs, without the impact loads and skeletal trauma common to most aerobic activities. Regular use of the Stepmill 7000 PT exercise system strengthens and conditions the heart and the following lower body muscle groups: gluteals, quadriceps, hamstrings, and calf muscles.



# CONTENTS

<b>SAFETY GUIDELINES .....</b>	<b>1</b>
<b>INSTALLATION INSTRUCTIONS .....</b>	<b>3</b>
<b>BASIC OPERATING INSTRUCTIONS .....</b>	<b>6</b>
General Guidelines for Safe Operation .....	6
Your First Workout on the StairMaster® Stepmill® 7000 PT Exercise System .....	6
The ATTRACT Mode .....	6
Basic Instructions for First-Time Users .....	7
End-of-Workout Summary .....	8
<b>POLAR® HEART RATE .....</b>	<b>9</b>
<b>7000 PT CONSOLE .....</b>	<b>10</b>
The Text Bar .....	10
The Display .....	10
The Function Keypad .....	11
The Exercise Program Keypad .....	12
The Quick Start Option .....	13
The Submaximal Fitness Test .....	13
The Stair Climb Test for Fire Fighters .....	14
Turning the CPAT Stair Climb Test on .....	15
Turning the NYCFD Stair Climb Test on .....	15
Preset Exercise Programs .....	16
The Jackpot Option .....	16
Turning the Jackpot Option On and Off .....	17
Customizing Your Exercise Program .....	17
Programming Your Workout .....	17
Using a Custom Program .....	18
Customizing The Text Bar Scrolling Message .....	18
Editing the Scrolling Message .....	19
Changing the Console Units and Prompt Language .....	20
Console Codes .....	20

# CONTENTS

<b>MAINTENANCE INSTRUCTIONS .....</b>	<b>22</b>
Helpful Hints .....	22
Tool List .....	22
Maintenance Records .....	22
Initial Service .....	23
Preventative maintenance .....	23
Cleaning and Inspecting .....	23
Lubrication .....	24
<b>TROUBLESHOOTING .....</b>	<b>27</b>
General Troubleshooting Guidelines .....	27
Troubleshooting the Electrical System .....	27
The Console Fails to Power Up .....	27
Console Diagnostics Tests .....	30
The Display Test .....	30
The Speaker Test .....	30
The Keypad Test .....	31
The Speed Test .....	31
The Software Revision Level Test .....	31
The Polar® Heart Rate Test .....	32
Speed Control Problems .....	33
Load Resistor Test .....	37
Troubleshooting the Drive Train .....	38
<b>PARTS REMOVAL AND REPLACEMENT .....</b>	<b>41</b>
Covers .....	41
Side Covers .....	41
Top Cover .....	41
Back Cover .....	42
Bottom Cover .....	42
Console .....	42
Poly-V Belt .....	43
Drive Chain .....	43
Step Assembly .....	44
Step Chain Assembly .....	45
Upper (and Lower) Sprocket Assembly .....	47
Cable Assembly .....	49





# CONTENTS

Transmission Assembly .....	50
Alternator Assembly .....	51
Relay/Resistor Assembly .....	52

## **GROUNDING INSTRUCTIONS ..... 54**

## **FCC COMPLIANCE ..... 55**

## **CANADIAN DOC CLASS A COMPLIANCE ..... 55**

### **APPENDICES**

Important Phone Numbers .....	56
Figures 1 - 7 .....	57

### **LIST OF TABLES**

Table 1. Dimensions and Specifications for the StairMaster® 7000 PT Exercise System .....	3
Table 2. Fitness Rating Norms .....	14
Table 3. Character Codes for the Scrolling Message .....	19
Table 4. Console Codes .....	21
Table 5. Recommended Preventive Maintenance Schedule .....	27

### **LIST OF ILLUSTRATIONS**

Figure 1: Side Cover and Handrail Assemblies .....	57
Figure 2: Cover Fasteners .....	58
Figure 3: Step Assembly .....	59
Figure 4: Step Chain and Sprocket Assemblies .....	60
Figure 5: Transmission and Alternator Assemblies .....	61
Figure 6: Wiring Diagram .....	62
Figure 7: Relay Board .....	63

# SAFETY GUIDELINES

**WHEN USING ELECTRICAL EQUIPMENT, ALWAYS FOLLOW THESE BASIC PRECAUTIONS:**

## IMPORTANT SAFETY INSTRUCTIONS



This symbol appearing throughout this manual means Attention! Be Alert! Your safety is involved.

The following definitions apply to the words "Danger" and "Warning" found throughout this manual:

**DANGER** - Used to call attention to IMMEDIATE hazards which, if not avoided, will result in immediate, serious personal injury or loss of life.

**WARNING** - Used to call attention to POTENTIAL hazards that could result in personal injury or loss of life.

### READ ALL INSTRUCTIONS BEFORE USING THE MACHINE.



#### **DANGER**

To reduce the risk of electrical shock, always unplug the external power supply from the AC wall outlet before cleaning, maintaining, or repairing.



#### **WARNING**

To reduce the risk of burns, electric shock, or injury to persons:

1. The external power supply should always be unplugged from the AC wall outlet before removing or installing parts. Never make adjustments or repairs while an exercise program is in progress.
2. Close supervision is necessary whenever the machine is used by, on, or near children, invalids, or disabled persons.
3. Keep your hands away from all moving parts and keep your feet on the pedals while exercising. Do not operate with the side covers removed.



## SAFETY GUIDELINES

4. Use this machine only for its intended use as described in this manual. Do not use attachments or accessories other than those provided by StairMaster® Health & Fitness Products, Inc.
5. Do not use the external power supply if it has a damaged cord or plug, if it is not working properly, if it has been dropped or damaged, or dropped into water. Contact our Customer Service Department at (800) 331-3578 to replace a damaged part. International customers should contact their local distributor; refer to the Appendix for the appropriate phone number.
6. Connect the external power supply to a properly grounded AC wall outlet; refer to the "Grounding Instructions" section of this manual. Keep all cords away from heated surfaces.
7. Never drop or insert any object into any opening on the machine.
8. Do not use the machine outdoors.
9. Do not operate where aerosol (spray) products are being used.
10. To disconnect the external power supply, remove the plug from the AC wall outlet.

The safety level given by the design of this equipment can only be maintained when the equipment is regularly examined for damage and wear. Inoperable components should be replaced immediately or the equipment should be put out of use until it is repaired.

Failure to follow all guidelines may compromise the effectiveness of the exercise experience, expose yourself (and possibly others) to injury, and reduce the longevity of the machine.

**SAVE THESE INSTRUCTIONS**

# INSTALLATION INSTRUCTIONS

Before leaving the manufacturing facility in Tulsa, Oklahoma, your StairMaster® Stepmill® 7000 PT exercise system was thoroughly inspected and tested for proper operation. To minimize shipping damage, careful attention was given to making your machine ready for shipment.

The dimensions of the machine are listed in Table 1. Throughout this manual, all references to the left or right side and to the front or back are made as if you were on the machine, ready to exercise. For example, the white function keypad is located on the right side of the console.

**Table 1. Dimensions and Specifications for the StairMaster 7000 PT Exercise System**

<b>Physical Dimensions:</b>	
Length	50.0 inches (127 cm)
Width	29.0 inches (74 cm)
Height	78.0 inches (198 cm)
Weight	409 pounds (186 kg)
<b>Power Supply Specifications:</b>	
Output Voltage	12 to 19 VDC
Output Current Capacity	2.5 amps
Input Power Consumption	55 watts

The machine requires minor assembly before operation. You will need a pair of diagonal cutters or a pair of heavy-duty scissors. The Stepmill 7000 PT exercise system must be placed on a solid, level floor near an AC wall outlet. A minimum ceiling height of 9 feet (2.8 meters) and a doorway width of 29 inches (74 cm) is required.

1. Roll the machine to its desired location on its temporary wheels.
2. Have an assistant tilt the machine forward until the wheels are off the floor. Make sure the assistant can support the machine so you can remove the temporary wheels.

## INSTALLATION INSTRUCTIONS

- Remove the clevis pin from each wheel (See Drawing Below) and remove the wheels from the frame.

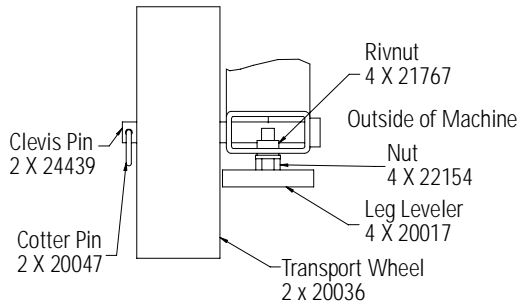

- Help your assistant lower the machine to the floor. Install and adjust the leg levelers as necessary to level the machine (see Above).
- If your machine was shipped outside North America, it will need additional assembly (if this is not the case, skip to step #6).
  - Use the fastener removal tool to remove the 8 fasteners on the back panel.
  - Mount both handrails onto the frame as shown in Figure 6.
  - Push the console cable assembly through the grommet in the frame and connect it to the main cable assembly (refer to Figure 6).
  - Install the console mount onto the handrails (refer to Figure 6).
  - Install the console and connect the console cable.
  - Reinstall the back panel and go to step #6.
- Unwrap the power supply assembly from the console and connect the DC power cable from the power supply to the power connector located on the bottom cover.
- Place the power supply on the floor near an AC wall outlet. To reduce the hazard of electrical shock, place the power supply in a location away from the machine and away from exposure to perspiration. You should not place your power supply on a carpet because it may overheat.
- Check to be sure that the input AC power rating marked on the power supply matches the available power. If it does not, obtain the matching power supply from StairMaster® Health & Fitness Products, Inc. before proceeding any further.

# INSTALLATION INSTRUCTIONS



## WARNING

TO REDUCE THE RISK OF ELECTRICAL SHOCK AND FIRE AND TO PREVENT SEVERE DAMAGE TO THE MACHINE, USE ONLY THE POWER SUPPLY APPROVED FOR USE WITH THIS EQUIPMENT. IN ADDITION, YOUR MACHINE MUST BE PROPERLY GROUNDED.

9. Connect the AC power cord to the AC wall outlet. Refer to the “Grounding Instructions” section of the Manual if the AC wall outlet does not accept a three-prong plug.
10. Watch the console. It should produce an audible sound when plugged in and then display a simulated EKG signal after the software revision level scrolling message. If it does not, unplug the power supply and then plug it back in. If the sound and/or the display are still not present, contact the Customer Service Department at (800) 331-3578. International customers should call their local distributor; refer to the Appendix for the phone number of the office nearest you.
11. When the console displays the simulated EKG signal, your Stepmill® 7000 PT exercise system is in the ATTRACT mode.
12. The console is set at the manufacturing facility to English language prompts and English units. While the console is in the ATTRACT mode, you can set the console for foreign language prompts or metric units. To change the language of the prompts, press [+ INCREASE], [7], [4], [2], [4], [ENTER]. Press the code number corresponding to the desired language according to Table 4 and then [ENTER].  
  
To change the console to metric units, press [+ INCREASE], [9], [7], [6], [0], [ENTER]. Press [1], [ENTER] to set the console to metric units. Press [0], [ENTER] to set the console to English units.
13. Custom-length DC cables and other accessories are available. Refer to the Appendix for the phone number of the office nearest you.

# BASIC OPERATING INSTRUCTIONS

## GENERAL GUIDELINES FOR SAFE OPERATION



### WARNING

THESE GUIDELINES ARE DIRECTED TO YOU, AS THE OWNER OF THE MACHINE. YOU SHOULD INSIST THAT ALL USERS FOLLOW THE SAME GUIDELINES. YOU SHOULD MAKE THIS MANUAL AVAILABLE TO ALL USERS.

1. Obtain a complete physical examination from your medical doctor and enlist a health/fitness professional's aid in developing an exercise program suitable for your current health status.
2. When working out for the first time, use the MANUAL exercise program at the lower speeds until you feel comfortable and capable of faster speeds.
3. The speed and duration of your exercise program should always be subject to how you feel. Never permit peer pressure to exceed your personal judgment while exercising.
4. Overweight or severely deconditioned individuals should be particularly cautious when using the machine for the first time. Even though such individuals may not have histories of serious physical problems, they may perceive the exercise to be far less intense than it really is, resulting in the possibility of overexertion or injury.
5. Although all equipment manufactured by StairMaster Health & Fitness Products, Inc. has been thoroughly inspected by the manufacturing facility prior to shipment, proper installation and regular maintenance are required to ensure safety. Maintenance is the sole responsibility of the owner.

## YOUR FIRST WORKOUT ON THE STAIRMASTER® STEPMILL® 7000 PT EXERCISE SYSTEM

### The ATTRACT Mode

The StairMaster Stepmill 7000 PT exercise system is ready to use when the console is in the inactive or ATTRACT mode. The ATTRACT mode is denoted by a

# BASIC OPERATING INSTRUCTIONS

simulated EKG signal in the display or a scrolling message in the text bar.

You can program your own message to scroll across the text bar. Refer to the “Customizing the Text Bar Scrolling Message” section of this Manual. A diagram of the console is shown in Figure 1.

## Basic Instructions for First-Time Users

1. Warm up with light calisthenics and easy stretching exercises for at least five minutes before beginning your exercise program.



### WARNING

IF AT ANY TIME DURING YOUR WORKOUT YOU FEEL CHEST PAIN, EXPERIENCE SEVERE MUSCULAR DISCOMFORT, FEEL FAINT, OR ARE SHORT OF BREATH, STOP EXERCISING IMMEDIATELY. IF THE CONDITION PERSISTS, YOU SHOULD CONSULT YOUR MEDICAL DOCTOR IMMEDIATELY.

2. Hold onto the handrails and step up onto the staircase. Stand up straight. The steps will rotate slowly.
3. Select the MANUAL exercise program so you can control the pace of your first workout and get used to the exercise motion.
4. Press [MANUAL] and then [ENTER]. The console will return to the ATTRACT mode if you do not press [ENTER] within ten seconds.
5. The console will prompt you to enter your body weight. Enter your weight in pounds (or kilograms if the console is set up for metric units). Correct entry errors by pressing [CLEAR] before you press [ENTER].
6. The console will prompt you to enter the workout time in one-minute increments between five and 60 minutes. Press [1], [0], [ENTER] to exercise for ten minutes.
7. Step up with one foot at a time. Try to stay towards the top of the staircase. When you begin to exercise, the console will display a single flashing light in the first interval.





## BASIC OPERATING INSTRUCTIONS

8. The flashing column shows which interval is active. Everything to the left of the active interval indicates completed intervals. As you become comfortable with the exercise motion, try pressing [+ INCREASE] and [- DECREASE] to adjust your speed.
9. Relax as much as possible while exercising and maintain an erect posture. Use the handrails for balance. Don't lock your elbows or lean on the console. Supporting your weight will reduce the exercise intensity and the console will overestimate the number of calories burned.
10. Select a speed (or intensity level) that allows you to step towards the top of the staircase. Faster is not always better. Exercise at a level that is consistent with your fitness level.
11. You can stop and rest for up to two minutes at any time during the workout. To rest, simply stop climbing and step down to the floor or press [START/STOP] (the stairs will continue to rotate very slowly). To resume your workout, press [YES] and begin climbing. To return the console to the ATTRACT mode, press [NO] during the pause. The console returns to the ATTRACT mode if you rest longer than two minutes or take two rest breaks.
12. When you have completed the last interval of the workout, the machine will slow down to the slowest speed. Step off the machine and cool down by walking or stretching for at least five minutes.

### End-of-Workout Summary

1. At the end of your workout, the message "GOAL ATTAINED" will scroll across the text bar. The total number of Calories you burned during your workout is then displayed for ten seconds. During this time, you may press any of the function keypad buttons to receive feedback concerning your workout. Refer to the "Function Keypad" section of this manual for details.
2. The summary information is stored in the console memory until the next person begins an exercise program. Press [WORKOUT STATS] to recall the summary for the last workout.



## POLAR® HEART RATE

The StairMaster® Stepmill® 7000 PT features Polar® heart rate monitoring. The system consists of the receiver located on the stepper, and a transmitter belt (purchased separately) worn across your chest. The transmitter belt senses your heart beat and sends a signal to the receiver. Your heart rate, in beats per minute, is shown on the console text bar.

Before you put the transmitter belt on, wet the two contact patches (the grooved rectangles on the reverse side of the belt). Secure the transmitter belt as high under the pectoral muscles (chest) as is comfortable. The transmitter belt should fit snugly and comfortably and allow normal breathing.

When the console detects a heart rate signal, heart rate is shown in the display automatically. The word "PULSE", your heart rate in beats per minute, and a pulsing heart icon are displayed in the text bar.

If you display a statistic other than heart rate during your workout, you can return to heart rate by pressing the white [0] key. Heart rate is part of the workout stats scrolling display. Average heart rate is shown at the end of your workout. If you wear a transmitter strap during the Fit Test, the average heart rate at the end of each stage is automatically used when estimating maximum aerobic capacity.

# 7000 PT CONSOLE

The StairMaster® Stepmill® 7000 PT exercise system console is divided into four sections: the text bar, display, the function keypad, and the exercise program keypad (refer to Drawing below).

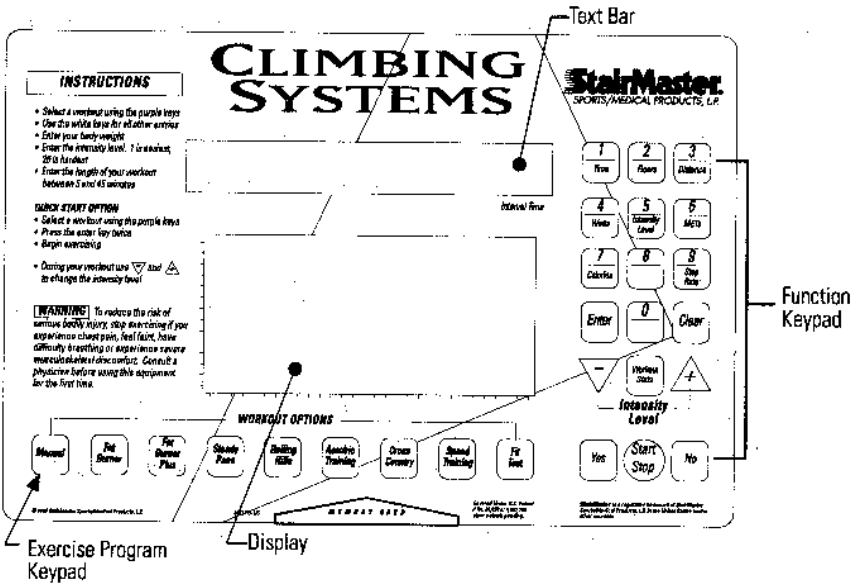

## THE TEXT BAR

Information regarding workout statistics and data entry is displayed or scrolled across the text bar. A countdown timer is located directly above the words "Interval Time". The timer shows the number of seconds remaining in the current interval.

## THE DISPLAY

For all exercise program options except MANUAL, a profile of the selected program appears in the display. A flashing interval column indicates where on the profile you are currently exercising (the active interval). The flashing, active column moves left to right across the display area as you complete each interval.

## THE FUNCTION KEYPAD

The function keypad is located on the right side of the console. Eight of the buttons have two pieces of information on them — a number and a workout statistic. Before the exercise program begins, the numbers are used to enter data in response to the console prompts. During the exercise program, the buttons are used to display workout statistics on the text bar.

**Time.** Displays the elapsed time of your workout, in minutes and seconds.

**Floors.** Shows the total number of floors you have climbed. There are 16 eight-inch steps per floor.

**Distance.** Provides the equivalent horizontal distance you would have traveled if you used the same amount of energy. There are 48 floors per horizontal mile.

**Watts.** Displays the power output in watts (746 watts = 1 horse power). Since power is a rate, watts will not accumulate over time. During a workout, this key displays the power output at that moment. Average power is shown for the workout summary.

**Intensity Level.** Shows the current level between 1 (the easiest) and 20 (the hardest). Shows the number of lights in the MANUAL program between 1 and 14.

**METs.** Gives you the relative energy cost of exercise. MET stands for multiples of the resting metabolic rate. While you are sitting quietly, your body consumes oxygen at the rate of about 3.5 milliliters per kilogram of body mass per minute. When you exercise, your body needs more oxygen in order to function. For example, exercising at 10 METs requires ten times the resting rate of oxygen consumption, or about 35 milliliters per kilogram per minute. During a workout, this key shows the current MET level. During the workout summary, the average MET level is displayed.

**Calories.** Provides a running total of the number of Calories burned during a workout.

## 7000 PT CONSOLE

**Step Rate.** Indicates the climbing speed in steps per minute. It is based on an average eight-inch step.

**Enter.** Confirms workout selections and stores the information used by the console to calculate workout statistics.

**Zero.** Press this key to see your heart rate during your workout. Press it during the workout summary to see your average heart rate.

**Clear.** Erases information from the console memory if pressed before [ENTER].

**[+ INCREASE] / [- DECREASE].** Increases or decreases the intensity level.

**Yes/No.** Respond to console prompts.

**Start/Stop.** If pressed while the console is in the ATTRACT mode, the console will display the "SELECT A PROGRAM" prompt.

## THE EXERCISE PROGRAM KEYPAD

The purple exercise keypad is located below the display and to the left of the function keypad. While the console is in the ATTRACT mode, press one of the exercise program keys to preview the desired workout.

The sequence of prompts for the preset exercise programs is slightly different than the sequence described earlier for the MANUAL program. After you press one of the exercise program buttons, the exercise program profile is scrolled across the display.

After the profile is scrolled, the prompts are:

- **"PRESS ENTER KEY TO SELECT"**
- **"ENTER BODY WEIGHT"** -- type in your body weight in pounds (or kilograms if your console is set to metric units).
- **"ENTER LEVEL 1 - 20"** -- select your intensity level with level 1 being the easiest and level 20 the hardest.

- **"ENTER TIME 5 - 60"** -- select the workout duration in one minute increments from five to 60.

### **The Quick Start Option**

You can quickly start any workout by first pressing one of the purple exercise program keys and then pressing [ENTER] twice. You do not have to enter any other information. The length of the workout is set automatically and varies with the program. Quick starting MANUAL gives you a 15 minute workout. The preprogrammed workouts last five minutes for every thirty intervals. So, a 60 interval program will last 10 minutes. All workout stats displayed at the end of a workout are based on a 175 lb. body weight. *The Submaximal Fitness Test does not have a quick start option.*

### **The Submaximal Fitness Test**

The Fit Test is a program that estimates your maximal aerobic capacity based on your heart rate response to submaximal exercise. Start the Fit Test by pressing [FIT TEST] while the console is in the ATTRACT mode. You will be prompted to enter your age and gender after a short message is scrolled across the display.

Once you have entered the required information, you will step at the rate of 43 steps per minute for three minutes. At the end of the three minutes, you will need to enter your heart rate. The console will prompt you to find your pulse; use the artery below your thumb in your wrist or the artery in the side of your neck. Start counting the beats when the console prompts you—the first beat you feel is zero and then one and so on. Enter the number of beats you counted in the ten seconds. If you are using a heart rate monitor, enter your heart rate directly into the console.

You will continue to exercise for three minute bouts of increasing intensity until you reach a point where you have entered two heart rate responses between 19 and 25 counts (115-150 beats per minute). The test typically lasts from nine to 15 minutes.

## 7000 PT CONSOLE

At the end of the Fit Test, your results scroll across the display area. Prior to a three-minute cool down, your estimated aerobic capacity, expressed in metabolic equivalents (METs), is shown in the display area. Next, your results will be compared to normative values for others of your age and gender. These normative values are based on values developed by the world renowned exercise physiologist, Dr. Per Olaf Åstrand, and are shown in Table 2. Your results are stored in the console until the next person starts an exercise program. Press [WORKOUT STATS] to review your results.

**Table 2. Fitness Rating Norms**

Rating	Low	Fair	Average	Above Average	Superior
<b>Gender/Age</b>					
<b>Men</b>					
20-29	<10.8	11.1-12.3	12.6-16.0	16.3-19.7	20.0+
30-39	<9.7	10.0-11.1	11.4-14.6	14.8-18.3	18.6+
40-49	<8.6	8.8-10.0	10.3-13.4	13.7-17.1	17.4+
50-59	<7.1	7.4-8.8	9.1-12.3	12.6-15.7	16.0+
60-69	<6.0	6.3-7.4	7.7-11.1	11.4-14.0	14.3+
<b>Women</b>					
20-29	<8.0	8.3-9.7	10.0-13.7	14.0-16.8	17.1+
30-39	<7.7	8.0-9.4	9.7-13.4	13.7-16.6	16.8+
40-49	<7.1	7.4-8.8	9.1-12.8	13.1-16.0	16.3+
50-59	<6.0	6.3-7.7	8.0-11.7	12.0-14.0	14.3+
60-69	<4.8	5.1-6.3	6.6-10.3	10.6-12.6	12.8+

### The Stair Climb Test for Fire Fighters

The StairMaster® Stepmill® 7000 PT is routinely used to assess the aerobic fitness levels of fire fighter candidates in full protective gear carrying heavy equipment. The Candidate's Physical Ability Test (CPAT), approved by the International Association of Fire Fighters (IAFF) and reviewed by the U.S. Justice Department, requires each candidate to step on the 7000 PT at a predetermined stepping pace for a specific period of time. There are two fire fighter specific Stair Climb Test programs in the 7000 PT console. The first test is the CPAT Stair Climb Test. The second test is a modified version of the CPAT test that is used by the New York City Fire Department (NYCFD).

**CPAT Stair Climb Test:** The first phase is a warm-up interval at intensity level three and lasts twenty-seconds. At the end of the first interval the time counter will reset to zero. The second phase continues through nine twenty-second intervals at intensity level four. The CPAT Stair Climb Test has a total of ten intervals and lasts for three minutes, twenty seconds.

**NYCFD Stair Climb Test:** The first phase is a warm-up interval at intensity level three and lasts sixty-seconds. You will then have a sixty-second rest period. At the end of the rest period the time counter will reset to zero. The second phase is at intensity level four and lasts for five minutes, twelve seconds.

### **Turning on the CPAT Stair Climb Test**

1. The console must be in the ATTRACT mode (noted by a simulated EKG signal in the console display). Press [+INCREASE], [7], [7], [0], [8], [ENTER], [1], [ENTER] on the console keypad. Make sure to press in the middle of each key and be aware that the corresponding numbers will not show in the console display.
2. Start the Stair Climb Test by pressing [FIT TEST] on the console program key pad.

***Note: The steps will start to rotate immediately after pressing [FIT TEST].***

### **Turning on the NYCFD Stair Climb Test**

1. The console must be in the ATTRACT mode (noted by a simulated EKG signal in the console display). Press [+INCREASE], [7], [7], [0], [8], [ENTER], [2], [ENTER] on the console keypad. Make sure to press in the middle of each key and be aware that the corresponding numbers will not show in the console display.
2. Start the Stair Climb Test by pressing [FIT TEST] on the console program key pad.

***Note: The steps will start to rotate immediately after pressing [FIT TEST].***





## 7000 PT CONSOLE

### Preset Exercise Programs

There are seven preset exercise programs. The exercise speed during the programs varies automatically over 14 increments within each of the 20 different intensity levels. Varying the intensity of an exercise program does not change the profile shown on the display. Change the intensity level of your workout by pressing [+ INCREASE] or [- DECREASE]. For each level, the average energy cost of all programs is about the same.

The **FAT BURNER** program is a 60 interval workout designed for people just starting a weight control program.

The **FAT BURNER PLUS** program is similar but has 90 intervals. It is meant for the longer workouts you will need as your fitness level increases.

The **STEADY PACE** and **ROLLING HILLS** programs are 30 interval workouts with gradual speed changes. They are geared for those who are just starting to exercise or for those who need an easy day of recovery exercise.

The **AEROBIC TRAINING** program is a 60 interval workout with slightly more varied speed changes. It is ideal for those long, slow workouts to increase your aerobic capacity.

The **CROSS COUNTRY** and **SPEED TRAINING** programs are 90 interval workouts with lots of speed changes

### THE JACKPOT OPTION

When you finish your workout, a "GOAL ATTAINED" message is normally displayed in the text bar. This message may be replaced by a Native American casino style slot machine. When the wheels of the slots stop turning, the console display will spell out either "YOU WIN" or "THE END". The odds of winning may be programmed anywhere from 1-in-1 to 1-in-999. The computer will then randomly select a winner and display "YOU WIN", otherwise it will display "THE END." Workout statistics are shown, as usual, after the jackpot message.

Commercial owners often use the jackpot option to further stimulate consumer interest in their establishment and to add variety to their overall workout program. Many such owners offer a prize or some tangible incentive for individuals who win while using the jackpot option. If there is only one prize, you should remember to disable the option after there is a winner. The jackpot option remains in effect until disabled by entering zero odds. StairMaster® assumes no liability stemming from the use of the jackpot option. Laws or ordinances in your area may govern the use of this option.

### **Turning On and Off the Jackpot Option**

1. The console must be in the ATTRACT mode. Press [INCREASE], [7707], [ENTER].
2. The prompt "ENTER ODDS" will appear in the console display. Enter the numeric odds you have selected, between 1 and 999.
3. The jackpot results are saved in the console memory until the next workout is started. Press [WORKOUT STATS] to review the results.
4. Program the odds to zero to turn the jackpot option off and to return to having the "GOAL ATTAINED" message appear after you finish your workout.

### **CUSTOMIZING YOUR EXERCISE PROGRAM**

The StairMaster® Stepmill® 7000 PT exercise system console has enough memory space for nine exercise programs of your design. Only the exercise profile is saved, your body weight, the intensity level and the workout time must be entered each time the custom program is used.

### **Programming Your Workout**

1. The console must be in the ATTRACT mode. Press [+ INCREASE], [1], [6], [5], [0], [ENTER]. Press the exercise program keypad button that you want to assign to your custom program.
2. If you select an exercise program keypad button that is already



## 7000 PT CONSOLE

programmed, the profile will appear; it can be modified or completely rewritten. If the exercise program keypad button was not previously programmed, you will see a single row of dots along the bottom of the display.

3. The flashing dot or column indicates which interval can be modified. Press the [+ INCREASE] or [- DECREASE] to make the column taller or shorter. Press [ENTER] to move one column to the right and [CLEAR] to move one column to the left.
4. When all of the intervals are correctly programmed, press [YES] to save the profile. Press [START/STOP] to abort the programming process without saving the profile.

### Using a Custom Program

1. Press [- DECREASE] and the exercise program keypad button you assigned to the custom program.
2. Enter your body weight, the intensity level and the workout time in response to the prompts.

### CUSTOMIZING THE TEXT BAR SCROLLING MESSAGE

The message that scrolls across the text bar during the ATTRACT mode can be replaced with a message of your choice. The console accepts messages up to 128 characters in length, including spaces. To program your message:

1. Encode your message using the character codes listed in Table 3.
2. While the console is in the ATTRACT mode, press [+ INCREASE], [7], [6], [0], [7], [ENTER].
3. Enter the two-digit code for each letter of your message. The letter will appear in the text bar as you press the second digit of each code. Do not press [ENTER] between the code numbers. If you make a mistake while entering the codes, press [CLEAR] to erase the last character entered.

4. For example, to program the message "EXERCISE IS FUN", press [+ INCREASE], [7], [6], [0], [7], [ENTER]. Then press [1], [5], [3], [4], [1], [5], [2], [8], [1], [3], [1], [9], [2], [9], [1], [5], [1], [0], [1], [9], [2], [9], [1], [0], [1], [6], [3], [1], [2], [4], [ENTER]. At that point, your message will begin scrolling.

**Table 3. Character Codes for the Scrolling Message**

Character	Code	Character	Code	Character	Code
0	00	M	23	í	46
1	01	N	24	À	47
2	02	O	25	Î	48
3	03	P	26	È	49
4	04	Q	27	Â	50
5	05	R	28	Ç	51
6	06	S	29	Ê	52
7	07	T	30	¿	53
8	08	U	31	+	54
9	09	V	32	\$	55
SPACE	10	W	33	.	56
A	11	X	34	,	57
B	12	Y	35	%	58
C	13	Z	36	?	59
D	14	Ä	37	´	60
E	15	Ü	38	!	61
F	16	Ö	39	-	62
G	17	ß	40	#	63
H	18	Å	41	:	64
I	19	Á	42	;	65
J	20	Ó	43	)	66
K	21	É	44	(	67
L	22	Ñ	45	/	68

### Editing the Scrolling Message

1. While the console is in the ATTRACT mode, press [+ INCREASE], [7], [6], [0], [7], [ENTER] to display the first character of the message onto the text bar.
2. Press [+ INCREASE] or [- DECREASE] to scroll through the message character-by- character.



## 7000 PT CONSOLE

3. Press [CLEAR] to delete the last character displayed on the text bar. Press [ENTER] to end the editing process.
4. To edit multiple characters at one time, press [9], [9], [ENTER] to erase all of the characters to the right of the last character displayed on the text bar.
5. To erase the entire message, press [+ INCREASE], [1], [0], [5], [ENTER] while in the ATTRACT mode.
6. The edited message will scroll across the text bar. If you have erased the entire message, the text bar area will be blank during the ATTRACT mode.
7. Press [+ INCREASE], [2], [1], [2], [3], [ENTER] to display the default scrolling message on the text bar.
8. Press [+ INCREASE], [2], [1], [2], [1], [ENTER] to display your custom scrolling message on the text bar.

## CONSOLE CODES

The console codes and the corresponding functions are listed in Table 4. Press [+ INCREASE] before pressing the code's number keys, and then press [ENTER]. Some codes, like the one to change the language of the console prompts, have options that require you to press a number and then [ENTER] to select that number.

## CHANGING THE CONSOLE UNITS AND PROMPT LANGUAGE

The console is set at the manufacturing facility to English language prompts and English units. While the console is in the ATTRACT mode, you can set the console for foreign language prompts or metric units.

1. To change the prompt language, press [+ INCREASE], [7], [4], [2], [4], [ENTER]. Press the code number for the desired language and then press [ENTER].
2. To change the console to metric units, press [+ INCREASE], [9], [7], [6], [0], [ENTER] and then [1]. Press [+ INCREASE], [9], [7], [6], [0], [ENTER], [0] to change back to English units.

Table 4. Console Codes

Code	Function
105	Clears the custom programmed scrolling message
107	Activates the Diagnostic mode
0	Display test
1	Speaker test
2	Keypad test
3	Speed test
4	Software revision test
108	Heart rate software test
1650	Programs a custom workout
2121	Turns on the custom scrolling message
2123	Turns off the custom scrolling message
7424	Changes the language of the console prompts
7607	Turns on the custom message option
99	Text bar scrolling message editing function
7703	Displays machine usage information
7704	Turns the console speaker on or off
0	Turns the speaker on
1	Turns the speaker off
7705	Turns the Heart Rate feature on or off
0	Turns the Heart Rate feature on
1	Turns the Heart Rate feature off
7708	Changes the Fitness Test options
0	Turns the Submaximal Fitness Test on
1	Turns the CPAT Stair Climb Test on
2	Turns the NYCFD Stair Climb Test on
9760	Change the units displayed by the console
0	Changes the console to English units
1	Changes the console to metric units
9766	Change the software version
0	Changes to 4400 PT software
1	Changes to 7000 PT software
97405	Changes the maximum workout time
52475	Resets time limit to 60 minutes



# MAINTENANCE INSTRUCTIONS

## HELPFUL HINTS

Read all maintenance instructions thoroughly before beginning work. In some cases, an assistant is required to perform the necessary tasks. The safety level given by the design of this equipment can only be maintained when the equipment is regularly examined for damage and wear. Inoperable components shall be replaced immediately or the equipment shall be put out of use until it is repaired.

All references to the right or left side and to the front or back are made as if you were on the machine ready to exercise. For example, the power supply is plugged into the connector near the bottom of the right side cover.

## TOOL LIST

The following tools are needed to perform service and maintenance:

- Standard screwdriver
- Combination wrenches (sizes 7/16 - 3/4")
- Combination pliers
- Shop goggles or other eye protection
- Allen wrench set (sizes 5/64 - 1/4")
- Socket set or nut driver set (sizes 1/4 - 3/4" in 1/16" increments)
- Phillips screwdriver
- Adjustable wrench
- External snap ring pliers
- Wire stripper/crimper tool
- Volt-ohm meter (multimeter)
- Locking pliers

## MAINTENANCE RECORDS

The console will keep track of the following data on machine usage:

- The number of hours the power supply was turned on.
- The number of hours the machine was in use.
- The total number of floors climbed.
- The number of exercise programs started.
- The hours of MANUAL use.

To display the data, press [+ INCREASE], [7], [7], [0], [3], [ENTER] while the console is in the ATTRACT mode. The console will display the data in the sequence listed above. The machine may show a few hours of use due to testing at the manufacturing facility.

# MAINTENANCE INSTRUCTIONS

## INITIAL SERVICE

Upon receiving your machine, use a soft, clean towel to wipe off the dust which may have accumulated during shipping. Your new machine will require minor assembly. Refer to the “Installation Instructions” section of this Manual for details.

## PREVENTIVE MAINTENANCE

The procedures for performing the recommended preventive maintenance are summarized in Table 5. The schedule is based on normal usage in a commercial health club environment; adjust the schedule to meet actual machine usage. Refer to the “Parts Removal and Replacement” section of this Manual for all disassembly and assembly instructions.



### WARNING

TO AVOID INJURY DUE TO SLIPPERY PEDAL SURFACES, DO NOT USE PETROLEUM-BASED CLEANERS OR ARMORALL-TYPE PROTECTANTS ANYWHERE ON THIS MACHINE OR THE FLOOR MATS.

## Cleaning and Inspecting

1. DO NOT USE GLASS CLEANERS OR ANY OTHER HOUSEHOLD CLEANER ON THE CONSOLE. Clean the console daily with a water-dampened cloth and wipe dry after cleaning.
2. Clean the exterior of your Stepmill® 7000 PT exercise system daily with soap and water.
3. Thoroughly clean the entire machine at least once a week.
4. Inspect the painted surfaces of the exposed frame for any rust, bubbling or chips during the weekly cleaning. The salt in perspiration can damage the unpainted surfaces. Repair the damaged area with a rust-inhibitor paint. Contact our Customer Service Department at (800) 331-3578 to order a touch-up paint kit.



# MAINTENANCE INSTRUCTIONS

5. Clean the step hinges carefully. Perspiration tends to accumulate in the hinges, and this can lead to eventual corrosion.
6. Inspect the Poly-V belt for excessive wear during the weekly cleaning. Adjust the belt tension if necessary.

## Lubrication

The StairMaster® Stepmill® 7000 PT exercise system has six components that require periodic lubrication: the drive chain, the two step chains, the two bearing plates and the step hinges. These parts are shown in the figure below. You will need to remove the side covers to lubricate the chains and the bearing plates.

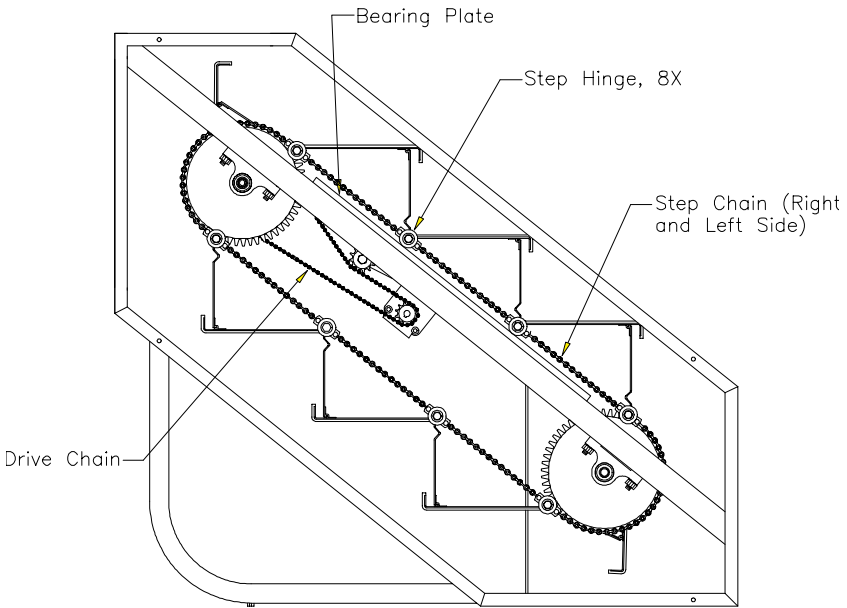

1. Place a protective mat on the floor while you are lubricating your machine. A rubber floor mat is available from StairMaster Health & Fitness Products, Inc.

## MAINTENANCE INSTRUCTIONS

2. Lubricate the chains monthly with 30W motor oil. Drip the oil onto the chain plates and rollers. Let the oil soak in for a few minutes and then remove any excess oil with a dry rag.
3. Remove the chains every three months to thoroughly clean and lubricate them. Use a mild degreaser and a stiff brush to remove dirt and corrosion from the chain. Read the instructions on the degreaser container before using.
4. Clean each bearing plate and lubricate it with multipurpose grease every three months. The plate is lubricated to reduce friction when the step shaft bearings roll over the plate.
5. Once per month, use 30W motor oil or brush light bearing grease into the step hinges to lubricate the hinges and to prevent corrosion. Wipe off all excess lubricant.



### **WARNING**

TO REDUCE THE POSSIBILITY OF SLIPPING, BE SURE THE STEP AREA IS FREE OF GREASE OR OIL. WIPE ANY EXCESS OIL OFF THE MACHINE SURFACES.

# MAINTENANCE INSTRUCTIONS

**Table 5. Recommended Preventive Maintenance Schedule**

PART	RECOMENDED ACTION	FREQUENCY	CLEANER	LUBRICANT
Exterior Surfaces	Clean	Daily	Soap & water	N/A
Console	Wipe Clean	Daily	Water	N/A
Poly-V Belt	Inspect and adjust if necessary	Weekly or after 70 hours of use	N/A	N/A
Step Chain Assembly	Lubricate	Monthly or after 300 hours of use	N/A	30W motor oil
	Clean and lubricate	Quarterly or after 900 hours of use	Mild degreaser	30W motor oil
Drive Chain	Lubricate	Weekly or after 70 hours of use	N/A	30W motor oil
	Clean and lubricate	Quarterly or after 900 hours of use	Mild degreaser	30W motor oil
Step Hinges	Lubricate	Monthly or after 300 hours of use	N/A	30W motor oil
Bearing Plate	Clean and lubricate	Quarterly or after 900 hours of use	Clean, dry rag	Multipurpose grease

**\*Note:** Use of lubricants other than those so specified will result in diminished performance and a shorter life span for that part.

### GENERAL TROUBLESHOOTING GUIDELINES

This section outlines several tests to systematically identify and isolate the cause of problems in the electrical system and the drive train. This troubleshooting section is organized into four basic problem sections: Electrical System, Console Diagnostics, Speed Control, and the Drive Train. The first step is to identify the problem. Once you have identified the problem, perform all the tests in exactly the same order as written. Refer to the “Parts Removal and Replacement” section of this Manual for all disassembly and assembly instructions. To order a replacement part, or to get help with the troubleshooting process, contact our Customer Service Department at (800) 331-3578. International customers should contact their local distributor or call (425) 823-1825.

### TROUBLESHOOTING THE ELECTRICAL SYSTEM

The electrical system consists of: the power supply, main cable, relay board, load resistor, and the console. In order to identify the component that is causing the problem, you must systematically test the system. You will need a volt-ohm meter (multimeter) to conduct portions of the following procedures. The console and power supply are not serviceable by the owner. If either of these parts are inoperable, they must be replaced. Opening the console or the power supply will void the warranty.

#### The Console Fails to Power Up

- A. Perform a visual check of the machine. Check the following things first:
  - 1. Is the power supply plugged in?
  - 2. Is the indicator light lit on the power supply? If it is, proceed to step #3. If the light is not on, go to step B.
  - 3. Replace or exchange your console with a console you know is good and retest the machine.
- B. Verify AC power.
  - 1. Disconnect the AC power cord from the AC wall outlet.

## TROUBLESHOOTING THE ELECTRICAL SYSTEM

2. Verify that the AC wall outlet is supplying the correct power in one of two ways: a) Use an AC voltmeter to verify that the AC line voltage is between 100 and 120 VAC (or between 220 and 240 VAC, if applicable) at the AC wall outlet; or b) Plug in an alternate AC-powered device (a lamp, for example). If the AC wall outlet is supplying the correct power, proceed to step #3. If the voltage is outside the range or if the device does not work when plugged into the AC wall outlet, consult an electrician for further assistance and then retest the AC wall outlet.
3. Plug the AC power cord into the wall outlet and proceed to the next section.

### C. Verify DC power.

1. Make sure that the AC power cord is plugged in and that the AC wall outlet is delivering the proper voltage.
2. The indicator light should be lit. If it is, proceed to step #3. If the indicator light is still not lit, replace the power supply and test the new power supply.
3. Disconnect the cable from the DC power connector located on the bottom cover. Use a DC voltmeter to verify 12-19 VDC at the end of the DC cable. Pin #1 is positive and pin #2 is negative. Proceed to step #4 if the VDC is within the range. Replace the power supply if the VDC is outside the range and test the new power supply.
4. Remove the right side cover. Reconnect the DC power cable to the machine. Locate the relay/resistor circuit board located just inside the frame, midway between the top and bottom steps (refer to Wiring Diagram 1). There are three red indicator lights along the bottom edge of the relay assembly circuit board. They are labeled, from top to bottom: Field, Power, and Relay. Ensure the black and white wire power connector (labeled J2 on the relay resistor circuit board) is securely connected to the relay resistor circuit board.
  - a. The Power light should be lit. If it is, go to step #5. If it is not, disconnect the power connector from the J2 position on the relay

## TROUBLESHOOTING THE ELECTRICAL SYSTEM

assembly circuit board (refer to Wiring Diagram 2). Use a DC voltmeter to measure the VDC at the power connector. Hole #1 (the white wire) is positive and hole #2 (the black wire) is negative. The reading should be between 12 and 19 VDC. If you are not getting power to the connector, replace the power connector assembly and retest.

- b. If you are getting the correct voltage at the power connector, reconnect it to the J2 position on the relay assembly circuit board. Disconnect the main cable connector at the J1 position of the relay assembly circuit board. Check the VDC reading at the silver tabs on the relay assembly circuit board. Tab #4 (labelled +/WHT) is positive and tab #5 (labelled GND/BLK) is negative (refer to Wiring Diagram 2). You should get a reading between 12 and 19 VDC. If your reading is not within the range, replace the relay assembly circuit board and retest.
  - c. If you are getting the correct voltage at tabs #4 and #5, check the VDC reading at the connector labeled position J1 on the relay assembly circuit board. Pin #4 is positive and pin #5 is negative. You should get a reading between 12 and 19 VDC. If your reading is not within the range, replace the relay assembly circuit board and retest.
  - d. If all of the above power tests produce VDC readings that are within range and the Power indicator light is still not lit, the Power indicator light is probably inoperable. Replace the relay assembly circuit board, reconnect all wires, and retest.
5. Remove the console and disconnect the console cable. Use a DC voltmeter to measure the VDC at pin #9 (positive) and pin #1 (negative) of the console cable connector. You should get a reading between 12 and 19 VDC. If the reading is not within the range, replace the cable assembly and retest.
  6. If your console still does not power up, contact the Customer Service Department at (800) 331-3578.



## CONSOLE DIAGNOSTIC TESTS

The following tests must be performed while the console is in the DIAGNOSTIC mode. To activate the DIAGNOSTIC mode, press [+ INCREASE], [1], [0], [7], [ENTER]. The numbers will not appear on the display area as you enter them. If the console fails any test, the console should be replaced or exchanged. To return to the ATTRACT mode, press either [CLEAR] or [START/STOP] while in the DIAGNOSTIC mode.

### THE DISPLAY TEST

Use this test if the console display or text bar exhibits blank spots during use. This test checks for inoperable Light Emitting Diodes (LEDs) in the console display and the text bar. If any LED will not light, replace the console.

1. Press [0] to start the test.
2. All LEDs in the console display will flash on and off as a block.
3. Press [CLEAR] to end the test.

### THE SPEAKER TEST

Use this test to make sure the console speaker is fully operational. The speaker will ascend and then descend through the musical scale.

1. Press [1] to start the test.
2. Press [ENTER] to pause the test. Press [CLEAR] to end the test.

### THE KEYPAD TEST

Perform this test if you are having trouble entering data into the console. If you cannot enter the DIAGNOSTIC mode due to an inoperable keypad, replace the console.

1. Press [2] to start the test.
2. The display LEDs will light up in an L-shaped formation, representing the keypad matrix. Pressing a button on either the exercise program keypad or



## CONSOLE DIAGNOSTIC TESTS

the function keypad will light an LED within the outline on the display that corresponds to that button's position on the console.

3. Firmly press each button. If the LED corresponding to the button you pushed does not light up, the keypad is bad and the console should be replaced.
4. Press [CLEAR] to test the LED and then end the test.

### THE SPEED TEST

Use this test to verify the electronic speed control routines of the console. You will need to briefly exercise on the machine for this test.

1. Press [3] to start the test.
2. The console will be set at a certain speed. The alternator speed, in RPM, is displayed on the text bar as "Target" and a single column of lights will light up on the display.
3. Begin exercising. As the stairs rotate, the text bar will alternately show the actual RPM and the target RPM.
4. Press [CLEAR] to return to the DIAGNOSTIC mode.

### THE SOFTWARE REVISION LEVEL TEST

This test allows you to check the version number of the software installed in the console.

1. Press [4] to start the test.
2. The software version number will be scrolled across the text bar. The console will automatically return to the DIAGNOSTIC mode.
3. Contact the Customer Service Department for the most current software revision update.



# CONSOLE DIAGNOSTIC TESTS

## THE POLAR® HEART RATE TEST

The Polar heart rate system is made up of the console, the heart rate receiver, and the chest strap (available separately). You can test each component by performing the following steps:

1. You will need to put a chest strap on in order to test the Polar heart rate. Before you put the chest strap on, wet the two contact patches. Secure the chest strap as high under your pectoral muscles (chest) as is comfortable. The chest strap should fit snugly, comfortably, and allow normal breathing.
2. While the console is in the ATTRACT mode (noted by a simulated EKG signal in the console display), or at the "SELECT A WORKOUT" prompt, press [+INCREASE], [1], [0], [8], [ENTER].
3. A flashing ♥ should be displayed in the console text bar. Your heart rate, in beats per minute, will show next to the heart icon. If the heart icon does not show, or if your heart rate is not displayed in the text bar then you have a problem with either the console, chest strap, or heart rate receiver.
4. Test your chest strap with a machine that you know is working, or with a heart rate watch that you know is working.
5. If possible, replace or exchange your console with a console (from the same type of machine) that you know is working and retest the machine.
6. Visually check that the heart rate receiver is positioned correctly in the neck cover. The heart rate receiver jack should point down. Ensure that the heart rate receiver is connected to the console, and that the connection is not loose. If possible, swap the heart rate receiver with one from another machine.
7. If the problem still exists, contact the Customer Service Department at 800-331-3578.

# SPEED CONTROL PROBLEMS

If you have problems with erratic speed control while operating the machine, the cause may be either electrical or mechanical in nature. You will have to remove the side covers to conduct most of these tests.

A. Perform a visual check of the machine. Check the following things first:

1. Inspect the Poly- V belt for proper tension and excessive wear. A loose belt will cause excessive noise and wear. The machine will run sluggishly if the belt is too tight.
2. Replace a worn or frayed Poly-V belt. Adjust the belt so that there is 1/10" (0.3 cm) deflection at a point midway between the alternator and transmission pulleys with fingertip pressure (See Drawing Below).

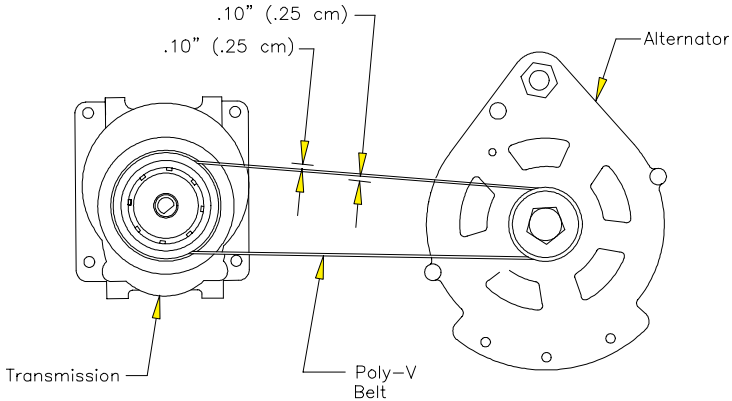

3. Check for proper wire connections on the alternator, relay assembly circuit board, and load resistor (See Drawing Below).

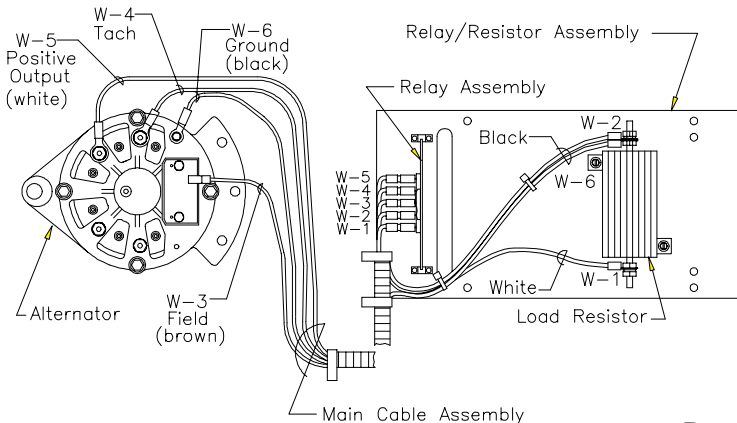

# SPEED CONTROL PROBLEMS

4. Replace or exchange the console with another console you know is good and retest the machine.
- B. Check the relay assembly circuit board while the console is in the ATTRACT mode. You will need an assistant to complete the test of the relay assembly circuit board.
1. Remove the right side cover. Locate the relay assembly circuit board located just inside the frame, midway between the top and bottom steps (refer to Wiring Diagram). There are three red indicator lights along the bottom edge of the circuit board. They are labeled, from top to bottom: Field, Power, and Relay. Ensure the black and white wire power connector (labeled J2 on the relay assembly circuit board) is securely connected to the relay assembly circuit board (refer to Figure Below).

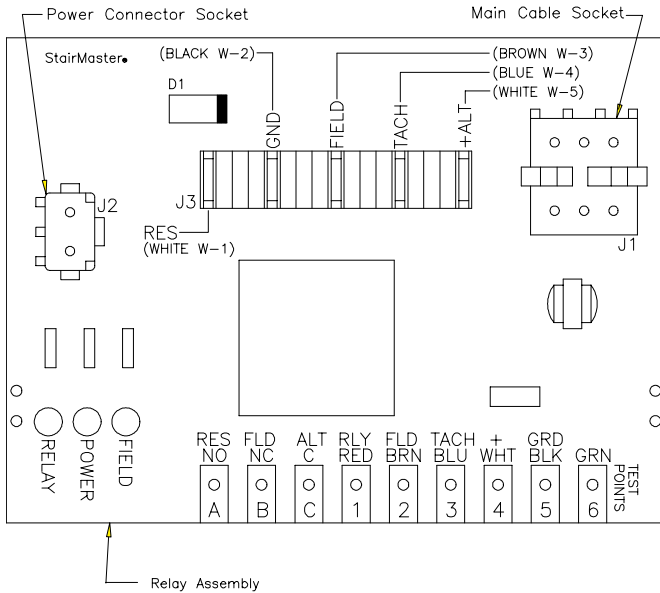

2. If the Power light is lit, go to step #3. If it is not, perform the tests as described in step 4b - c of the "Console Fails to Power Up" section.
3. The relay indicator light should be lit. If it is lit, proceed to step #5. If it is not, use a jumper wire on the relay assembly circuit board. Jump the silver tabs #1 (labeled RLY/RED) and #5 (labeled GRD/BLK) (refer

## SPEED CONTROL PROBLEMS

to Figure on page. 34). The relay indicator should light up. If it does, go to step #4. If the relay indicator does not light up, the relay assembly circuit board must be replaced. Replace the relay assembly circuit board and retest the machine.

4. You must check the cable assembly for continuity if the relay indicator lit up when you jumped tabs #1 and #5.
  - a. Unplug the main cable from the position labeled J1 on the relay assembly circuit board. Disconnect the console cable from the back of the console. Set your multimeter to the continuity check mode; on most meters, this will be the resistance or ohms setting.
  - b. Place one lead of the multimeter on pin #1 at the console connector end of the console cable (refer to Wiring Diagram). Place the other lead on pin #1 at the end of the main cable you disconnected from the relay assembly circuit board. You will get a reading of near zero ohms if there is continuity in the cable assembly.
  - c. Check continuity in both ends of the main cable assembly at pin #5.
  - d. If there is no continuity in the cable assembly at either pin, replace the cable assembly and retest. If there is continuity in the cable assembly at both pins and the relay resistor indicator is not lit, the console is inoperable and must be replaced.
5. Have your assistant step on the staircase (leave the console in the ATTRACT mode) while you check the field indicator light. It should be flickering. If it is and you still have a speed control problem, go to step #6.

If it is not flickering, ensure the following: the console cable is connected to the console; the console/main cable connection is secure; the connector at position J1 on the relay assembly circuit board is securely connected; that there is continuity in the cable assembly. To check for continuity:



## SPEED CONTROL PROBLEMS

- a. Unplug the connector at position J1 on the relay assembly circuit board. Disconnect the console cable from the back of the console. Set your multimeter to the continuity check mode; on most meters this will be the resistance or ohms setting.
  - b. Place one lead of the multimeter on pin #2 at the console connector end of the console cable. Place the other lead on pin #2 at the end of the main cable you disconnected from the relay assembly circuit board. You will get a reading of near zero ohms if there is continuity in the cable assembly.
  - c. If there is no continuity in the cable assembly, replace it and retest. If there is continuity in the cable assembly and the field indicator light is still not flickering, contact the Customer Service Department at (800) 331-3578 for further assistance.
6. If the field indicator was flickering while your assistant was on the machine and you still have a problem with speed control, you need to test the alternator.
- a. Disconnect the white wire (labeled positive output on the alternator) and the brown wire (labeled "Field" on the alternator). Use a jumper wire to jump the Field and positive output terminals of the alternator.
  - b. Have your assistant step onto the staircase. Does the staircase slow down? If it does not, you need to replace the alternator. If the staircase does slow down, contact the Customer Service Department for further assistance.
  - c. Replace or exchange the alternator with another alternator you know is good and retest the machine.
  - d. Test the load resistor as outlined in the "Load Resistor Test" section of this Manual. If the speed control problem still exists, contact the Customer Service Department at (800) 331-3578 for further assistance.

## LOAD RESISTOR TEST

The alternators are heavy-duty models designed to withstand the rigors of commercial use. One possible reason for repeated failure is an inoperable load resistor. To test the load resistor:

1. Unplug the AC power cord from the AC wall outlet.
2. Locate the load resistor mounted to the relay board assembly just under the staircase.
3. Disconnect one black wire from the resistor (See Drawing Below).
4. Set your multimeter for R x 1 or the lowest available resistance range. If you have an analog multimeter, touch the two leads together and adjust the meter for a zero reading.
5. Place one lead on Tab A and one lead on Tab 5 of the relay assembly circuit board (See Drawing Below). You should get a reading of approximately 1.0 ohm or less.
6. Replace the load resistor if the reading is out of range and retest the new load resistor.
7. Reconnect the AC power cord and reinstall the right side cover.
8. If the problem still exists, contact the Customer Service Department at (800) 331-3578 for further assistance.

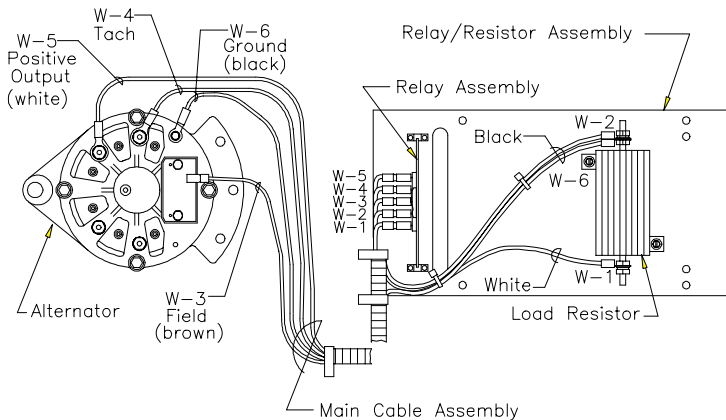

## TROUBLESHOOTING THE DRIVE TRAIN

If you hear a grinding or clicking noise, or experience excessive vibration during exercise, or if the steps are not functioning properly, you probably have a problem in the drive train. Attempt to isolate the problem area by performing the following tests in precisely the order listed below. Refer to the "Parts Removal and Replacement" Section of this Manual for all disassembly and assembly instructions.

1. Unplug the power supply from the AC wall outlet and remove the side covers.



### WARNING

TO REDUCE THE RISK OF INJURY, DO NOT OPERATE THE MACHINE WHILE THE SIDE COVERS ARE REMOVED. DO NOT ROTATE THE STAIRS WHILE ANYONE'S HANDS ARE INSIDE THE MACHINE.

2. Check the condition and the tension level of the Poly-V belt. Replace the belt if it is excessively worn.
  - a. Adjust the tension level so that you can deflect either side of the belt 1/10" (0.3 cm) at the center between the alternator and the transmission pulleys (See Drawing Below). Noise can be generated by a belt that is too tight or too loose.

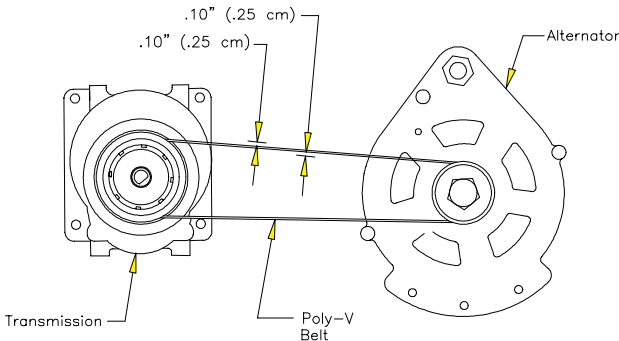

- b. If the noise is still present, remove the Poly-V belt and rotate the staircase without standing on it. With the Poly-V belt removed, the staircase will rotate very quickly.
- c. If the noise no longer exists, replace the alternator.

## TROUBLESHOOTING THE DRIVE TRAIN

3. Check the condition of the alternator.
  - a. Unplug the alternator from the relay board and remove the Poly-V belt.
  - b. Spin the alternator pulley with your fingers. It should spin freely and remain spinning for at least one and one-half revolutions. If it does not spin as it should, the bearings may be bad and the alternator should be replaced.
  - c. If the pulley does spin freely, check the alternator for noise, roughness, or the presence of black powder inside the alternator or near the outside of the case. If any of these conditions exist, the brushes may be bad and the alternator should be replaced.
  - d. Reconnect the Poly-V belt and adjust the belt tension.
4. Check the drive chain mechanism. Rotate the stairs and look for chain links that do not flex as the chain travels over the sprockets. If the links are frozen or sticking, replace the chain.
5. Check the transmission.
  - a. Rotate the steps by hand and listen for the noise.
  - b. If you hear the noise, remove the drive chain and the Poly-V belt. Rotate the steps by hand again and listen for the noise. If the noise has gone away, replace the transmission.
6. Check the step chain assemblies.
  - a. Have your assistant slowly exercise on the machine. Observe the staircase. If the staircase moves to the left or right during exercise, ensure the set screws in the bearing adjusters are tight.
  - b. Rotate the stairs and look for chain links that do not flex as the chain travels over the sprockets. If the links are frozen or sticking, replace the chain.



## TROUBLESHOOTING THE DRIVE TRAIN

7. Check the condition of the upper and lower sprocket assemblies. Replace the sprocket assembly if it is worn excessively, has broken teeth, or if it is bent.
8. Check the alignment of the upper and the lower sprocket assemblies. The outside face of the upper and lower sprockets should be 1-11/16" (4.3 cm) from the outside edge of the left frame rail. Loosen the nuts on the pillow block bearing collars and tighten or loosen the bearing adjuster set screws until the distance to both sprockets is correct. Tighten the pillow block bearing nuts and verify the distance.
9. Check the step assembly.

- a. Rotate the steps and check the hinges, step shafts, washers, and bearings (See Figure to Right) for wear, corrosion and lack of lubrication. Replace any worn parts.
- b. Ensure the nuts at each step shaft end are tight.

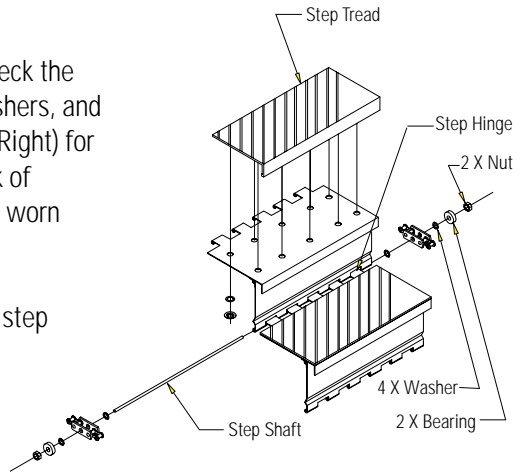

10. Reinstall all parts. If the problem still exists, contact the Customer Service Department at (800) 331-3578 for further assistance.

# PARTS REMOVAL AND REPLACEMENT

## COVERS



### WARNING

TO REDUCE THE RISK OF INJURY, DO NOT OPERATE THE MACHINE WHILE THE SIDE COVERS ARE REMOVED. DO NOT ROTATE THE STAIRS WHILE ANYONE'S HANDS ARE INSIDE THE MACHINE.

There are five covers on the machine: two side covers, a back cover, a bottom cover, and a top cover. The side covers overlap the top cover. The side covers must be removed before the top cover and/or the bottom cover can be removed.

All covers are held in place with reusable plastic fasteners (refer to Figure 5 for their location). To remove the fasteners, slide either end of the fastener removal tool under the edge of the pin head (refer to Figure 6). The pin should not be removed. Pull the cover away from the frame. Do NOT use the fastener removal tool or any other sharp tool to pry out the fastener base because you may damage the covers - use the fastener removal tool to remove the pin.

To reinstall the fastener, insert the base of the fastener through the cover and into the frame. When the base is in place, push the pin in all the way to secure the fastener.

### Side Covers

1. Remove the 14 fasteners on each side cover.
2. Pull the cover away from the frame.

### Top Cover

1. Remove both side covers.
2. Lift the top cover away from the frame.
3. Set the top cover in place. Secure the side covers to complete reinstallation.

# PARTS REMOVAL AND REPLACEMENT

## Back Cover

1. Remove the 8 fasteners and lift the back cover away from the frame.
2. Align the holes in the frame and the back cover. Secure the back cover with the 8 fasteners.

## Bottom Cover

1. Remove both side covers to gain access to the bottom cover fasteners.
2. Disconnect the DC power cable.
3. Remove the six fasteners and remove the bottom cover from the frame.
4. Reinstall the bottom cover, then the two side covers. Remember to connect the DC power cable.

## CONSOLE

1. Locate the mounting knobs on the back of the console (See cutaway view Below).
2. Loosen and remove the four mounting knobs and lock washers.
3. Lift up the console and unplug the console cable from the back of the console. Unplug the Polar® cable from the heart rate receiver.
4. Remove the console from the frame.
5. Reinstall the console by reversing the steps.

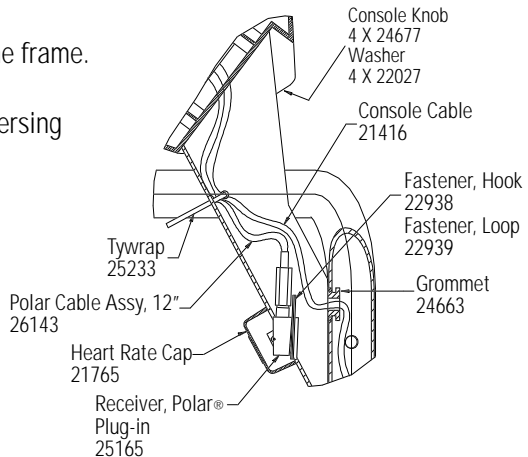

# PARTS REMOVAL AND REPLACEMENT

## POLY-V BELT



THE POLY-V BELT MUST BE ADJUSTED SO THAT THE CENTER OF EITHER SIDE CAN BE DEFLECTED 1/10" (0.3 CM) FROM ITS CENTER LINE WITH FINGER-TIP PRESSURE. A TIGHT BELT WILL CAUSE SLOW AND SLUGGISH OPERATION; A LOOSE BELT WILL CAUSE EXCESSIVE NOISE AND BELT WEAR.

1. Remove the left side cover.
2. Loosen the adjustment bolt that mounts the alternator to the slotted alternator brace then loosen the pivot nut.
3. Pivot the alternator forward to loosen the belt. Remove the Poly-V belt.
4. When reinstalling the Poly-V belt, pivot the alternator forward or back as necessary to allow 1/10" (0.3 cm) of play on either side of the belt (See Figure Below).

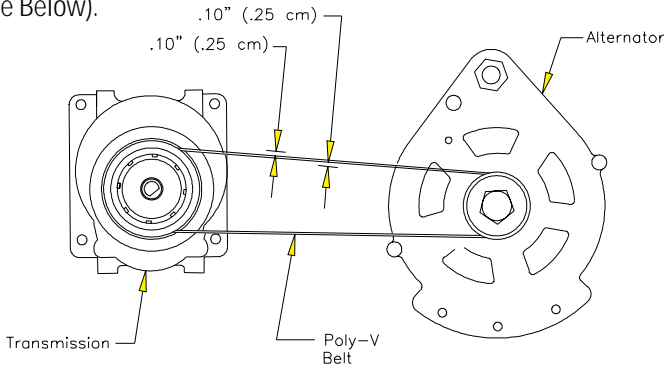

5. Tighten the adjustment bolt and verify the Poly-V belt tension.

## DRIVE CHAIN

1. Remove the left side cover.
2. Remove the retaining clip and retaining plate from the drive chain master link. Do not remove the master link from the drive chain yet.

## PARTS REMOVAL AND REPLACEMENT

3. Push up on the idler arm with one hand to relieve the tension on the drive chain (See Drawing Below). Remove the master link from one end of the drive chain and remove the drive chain from the sprockets.

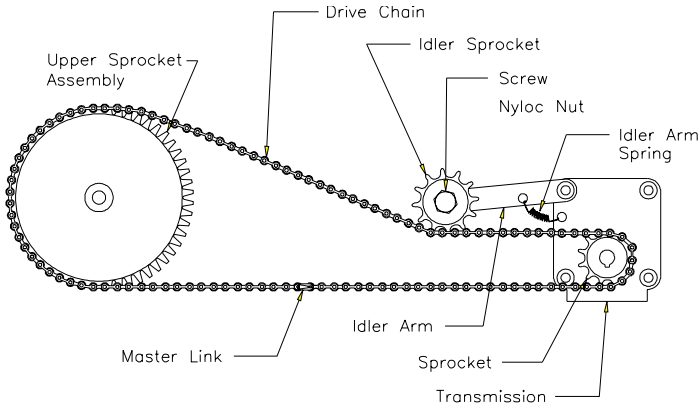

4. Install the new drive chain by reversing the steps.

### STEP ASSEMBLY

1. Remove the right and the left side covers.
2. Rotate the stairs until the step you want to remove is positioned in the middle of the staircase.
3. Loosen and remove the nut from one end of the step shaft on both the upper and the lower hinges of that step (See Figure to Right).
4. Remove the bearing and the washer from each step shaft.
5. Grasp the opposite step retaining nut with pliers or locking pliers. Pull the step shaft out of the upper and lower step hinges.

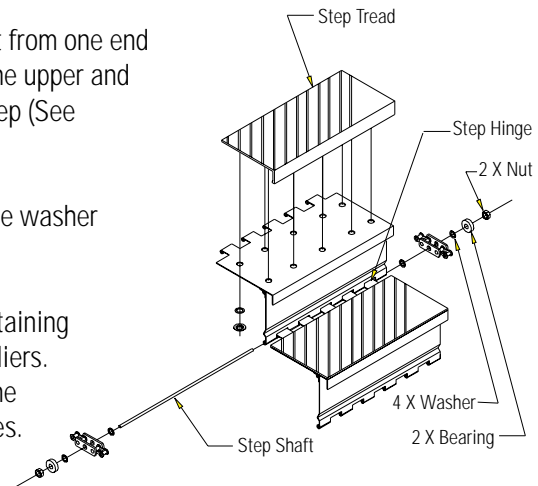

# PARTS REMOVAL AND REPLACEMENT

Be careful to not lose the washer located between the step and the modified link.

**Note:** Each step assembly weighs approximately 15 lbs. Be aware of finger placement when removing the step assembly.

6. Reinstall the step by reversing the procedures.

## STEP CHAIN ASSEMBLY

1. Remove the right and the left side covers.
2. Rotate the stairs to position the step chain master link on the lower span of the chain. It may be necessary to reduce the chain tension to remove the master link. Perform the following steps to reduce the chain tension:
  - Count and write down the number of exposed threads on the top bearing adjuster set screw for a reference when you reassemble the parts (See Figure Below).

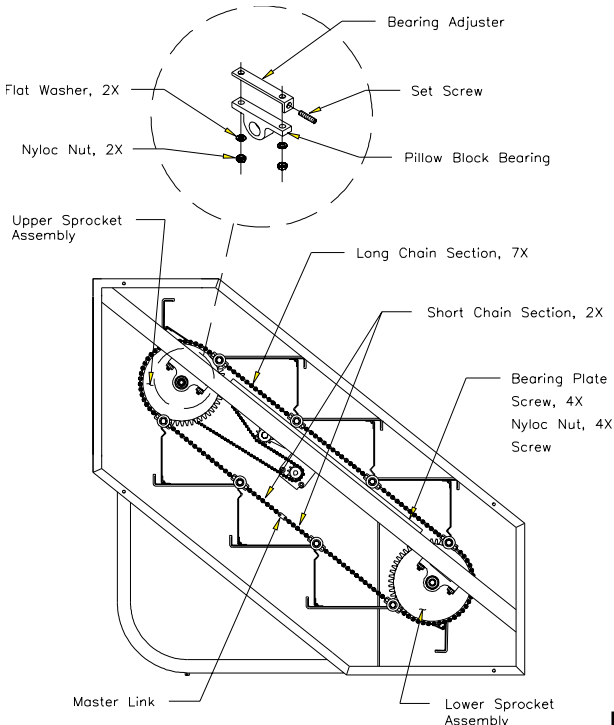



## PARTS REMOVAL AND REPLACEMENT

- Loosen the nuts on the pillow block bearing housing.
  - Loosen the bearing adjustment set screw until the chain tension level is relieved to a point where the master link may be disconnected.
3. Remove the master link.
  4. Using the old master link, connect the new chain assembly to the lower half of the old chain assembly.
  5. Remove the nut from the step shaft above the master link. It may be necessary to place another 5/16"-18 nut on the opposite end of the step shaft to gain leverage and remove the nut.
  6. Remove the bearing, the outer step shaft washer and the modified link of the old step chain assembly from the step shaft.
  7. Place the modified link of the new step chain assembly on the step shaft. Reinstall the outer step shaft washer, bearing and nut.
  8. Rotate the steps until the next step shaft is in approximately the same place as the previous step shaft.
  9. Repeat steps 6-8 until the new chain assembly is installed on the remaining step shafts.
  10. Remove the master link connecting the old chain with the new chain.
  11. Connect the new chain assembly together with the master link. Tighten the bearing adjustment set screw until the same number of threads as in step 2 are exposed. Tighten the nuts on the pillow block bearing housing.
  12. You should consider replacing the opposite step chain so that both chains will wear equally.
  13. Reassemble the machine in reverse order.

# PARTS REMOVAL AND REPLACEMENT

## UPPER (AND LOWER) SPROCKET ASSEMBLY

1. Remove the right and left side covers.
2. Remove all of the steps.
3. Remove the drive chain if you are removing the upper sprocket assembly.
4. Count and write down the number of exposed threads on the bearing adjuster set screws on both sides of the machine for a reference when you reassemble the parts (See Drawing Below).

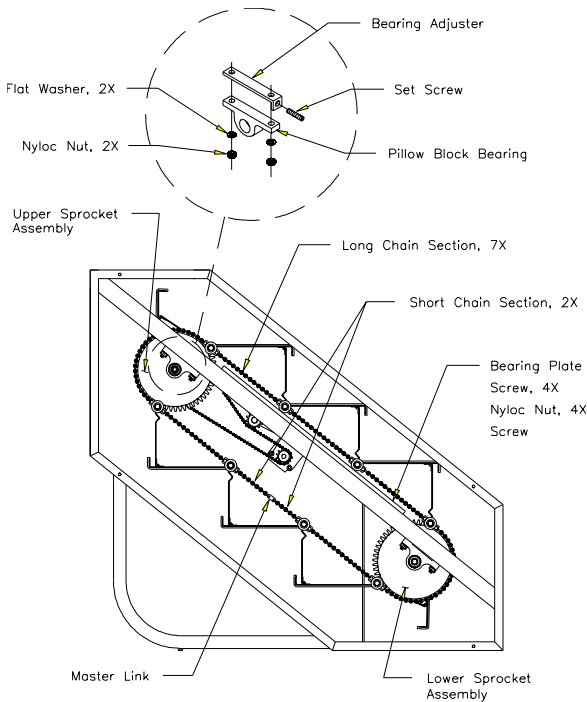

5. Remove the right and left step chain assemblies.
6. Loosen the adjustment screws until the tips of the screws are flush with the inside face of the bearing adjusters.





## PARTS REMOVAL AND REPLACEMENT

7. Have an assistant support the sprocket assembly. Loosen and remove the nuts on the pillow block bearing housing.
8. Remove the sprocket assembly from the frame.
9. Loosen the two set screws on both of the pillow block bearing collars and remove the pillow block bearings from the sprocket axle.
10. To reinstall the sprocket assembly:
  - Slide the pillow block bearings on both ends of the sprocket axle. Do not tighten the set screw on the pillow block bearing collars yet.
  - Place the bearing adjusters and the sprocket assembly onto the frame and start the pillow block bearing housing nuts onto the frame.
  - Slide the sprocket assembly toward the front of the machine while tightening the pillow block bearing housing nuts.
  - Align the sprocket assembly. The outside face of the left sprocket should be 1-11/16" (4.3 cm) from the outside edge of the left frame rail. Move the sprocket axle within the pillow block bearing collar as needed to get the correct distance.
  - When the distance is correct, tighten the pillow block bearing collar set screw on the left and right sides of the machine.
  - Loosen the pillow block bearing housing nuts slightly. Tighten the bearing adjuster set screws until the exact number of threads are exposed (refer to your notes taken earlier). Tighten the pillow block bearing housing nuts.
  - Check the alignment of the other sprocket at this time. If the distance from the outside edge of the left frame rail to the outside face of the sprocket is not 1-11/16" (4.3 cm), loosen the set screws on the left and right side pillow block bearing collars and adjust the axle. Tighten the pillow block bearing collar set screws on the machine and then go to step 11.

## PARTS REMOVAL AND REPLACEMENT

11. Complete the reassembly of the machine by performing steps 1- 4 in reverse order.

### CABLE ASSEMBLY

1. Remove the right side cover.
2. Remove the console and unplug the console cable and the Polar® heart rate cable from the back of the console (See Drawing Below). Unplug the plastic connectors at the console cable/main cable junction.

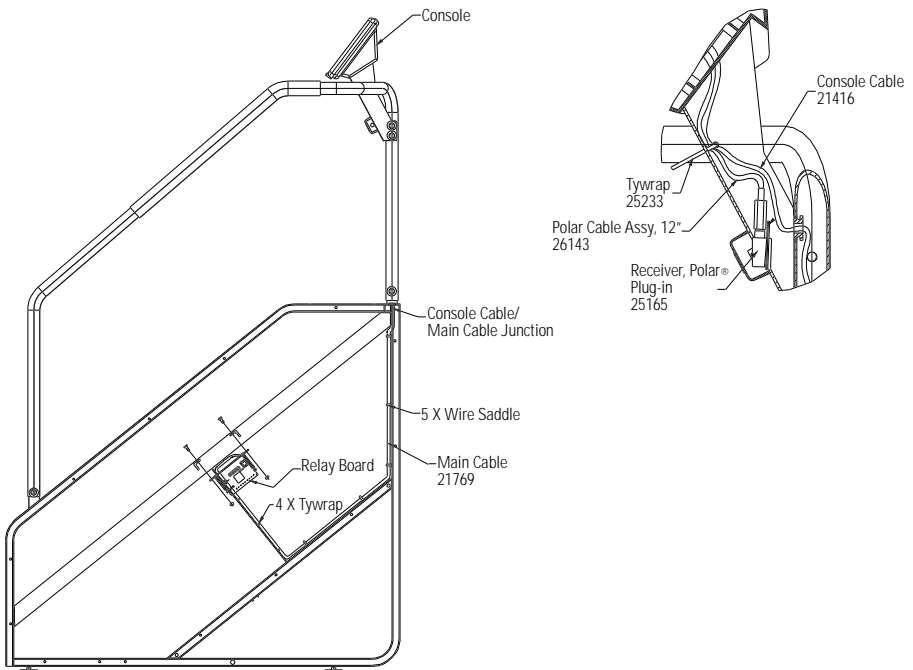

3. Hold the console connector and pull the console cable up and out of the handrails.
4. Reinstall the console cable by pushing the white plastic connector end down through the handrails. Do not connect the console, Polar heart rate, and the main cables.
5. Remove the main cable from the wire saddles.



## **PARTS REMOVAL AND REPLACEMENT**

6. Unplug the white plastic connector labeled J1 on the relay assembly circuit board.
7. Cut the four tyrap on the vertical support.
8. Remove the main cable from the frame.
9. To reinstall, place the main cable into the wire saddles. Reattach the cable to the vertical support with four tyrap.
10. Plug the white plastic connector of the main cable into the relay assembly circuit board at the spot labeled J1.
11. Plug the console cable into the back of the console. Reattach the console to the handrail mount. Plug the connectors together at the main cable/console cable junction.
12. Reinstall the right side cover. Reconnect the DC power cable.

## **TRANSMISSION ASSEMBLY**

1. Remove the left and right side covers.
2. Remove the step positioned in the middle of the staircase.
3. Remove the drive chain.
4. Remove the Poly-V belt. Inspect the belt for wear. Replace the belt if it is cracked, worn, torn, or cut.
5. Remove the transmission bracket by loosening and removing the mounting hardware on the alternator and the transmission.
6. Remove the transmission brace by loosening and removing the mounting hardware from the transmission and the frame.

## PARTS REMOVAL AND REPLACEMENT

- Support the transmission while loosening and removing the four transmission mounting bolts. Remove the transmission and rubber pad from the frame (See Drawing Below).

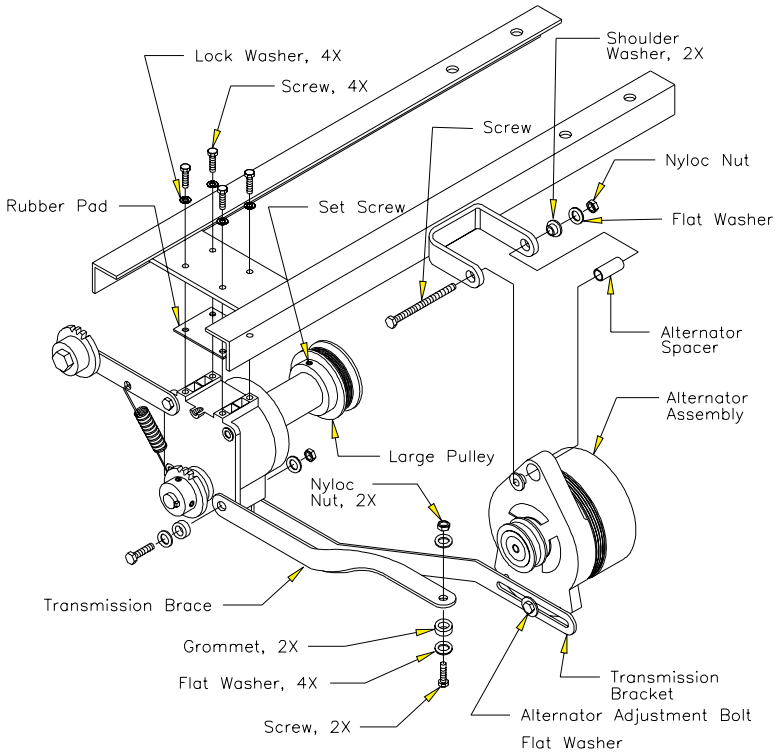

- Reinstall the transmission by reversing the removal procedures.
- Ensure the Poly-V belt is tensioned according to the procedures outlined in the "Poly-V Belt" section of this Manual.

### ALTERNATOR ASSEMBLY

- Remove the right and left side covers.
- Remove the step positioned in the middle of the staircase.
- Remove the wiring from the alternator terminals, noting the origin and color of the wires removed from each terminal.

## PARTS REMOVAL AND REPLACEMENT

4. Remove the Poly-V belt. Inspect the belt for wear. Replace the belt if it is cracked, worn, torn, or cut.
5. Remove the alternator adjustment bolt (See Drawing on Pg. 51).
6. Remove the nut, bolt and mounting hardware from the alternator bracket. Remove the alternator from the frame.
7. Reinstall the alternator by reversing the removal procedures. Be sure to verify the wiring connections.
8. Ensure the Poly-V belt is tensioned correctly (See Drawing Below).

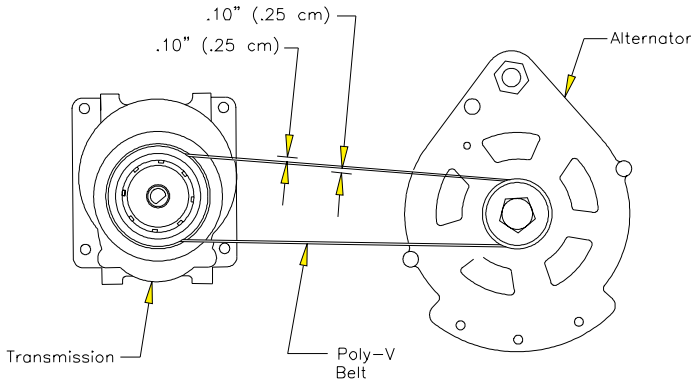

## RELAY/RESISTOR ASSEMBLY

1. Remove the left side cover.
2. Remove the step positioned in the middle of the staircase.
3. Remove the wiring from the alternator terminals, noting the origin and color of the wires that are removed from each terminal.
4. Unplug the main cable connector from the J1 position on the relay circuit board.

# PARTS REMOVAL AND REPLACEMENT

- Unplug the power connector from the J2 position on the relay circuit board.

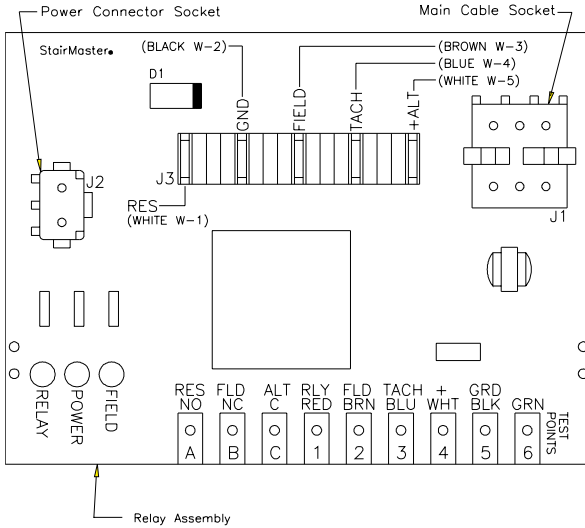

- Loosen and remove the four mounting bolts and remove the relay/resistor assembly from the frame.
- Reinstall the relay/resistor assembly in the reverse order. Verify the wiring connections before attaching the side cover.

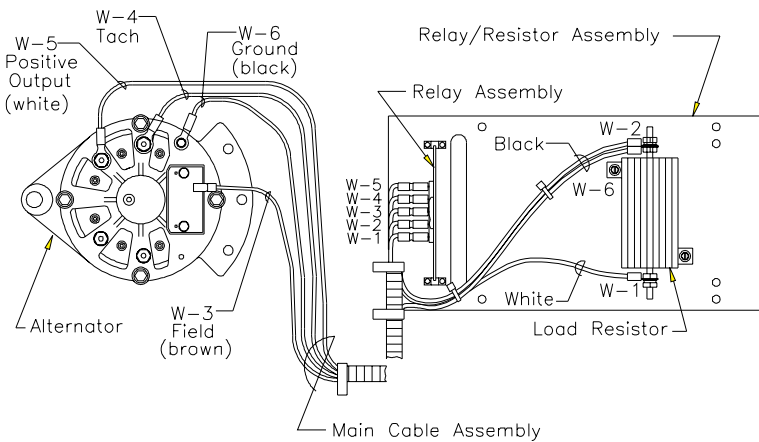

# GROUNDING INSTRUCTIONS

The machine must be grounded. If it should malfunction or break down, grounding provides the path of least resistance for the electric current, thereby reducing the risk of electric shock. This machine is equipped with a cord having an equipment-grounding conductor and a grounding plug that looks like the plug illustrated in sketch A in the Drawing below. International machines may vary. It must be plugged into an appropriate outlet that is properly installed and grounded in accordance with all local codes and ordinances.



**DANGER**

IMPROPER CONNECTION OF THE EQUIPMENT-GROUNDING CONNECTOR CAN RESULT IN THE RISK OF ELECTRIC SHOCK. CHECK WITH A QUALIFIED ELECTRICIAN OR SERVICE PERSON IF YOU ARE IN DOUBT AS TO WHETHER THE MACHINE IS PROPERLY GROUNDED. DO NOT MODIFY THE PLUG PROVIDED WITH THIS MACHINE. IF IT WILL NOT FIT THE AVAILABLE OUTLET, HAVE A PROPER OUTLET INSTALLED BY A QUALIFIED ELECTRICIAN.

A temporary adapter that looks like the adapter illustrated in sketches B and C may be used to connect this plug to a two-pole receptacle as shown in sketch B if a properly grounded outlet is not available. The temporary adapter should be used only until a properly grounded outlet (sketch A) can be installed by a qualified electrician. The green colored lug extending from the adapter must be connected to a permanent ground such as a properly grounded outlet box cover. Whenever an adapter is used, it must be held in place by a metal screw.

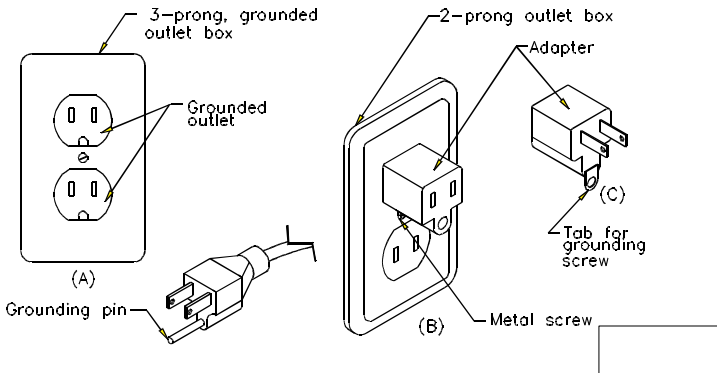

**Grounding System**

## FCC COMPLIANCE

This equipment has been tested and found to comply with the limits for a Class A digital device, pursuant to Part 15 of the FCC rules. These limits are designed to provide reasonable protection against harmful interference when the equipment is operated in a commercial environment. This equipment generates, uses, and can radiate radio frequency energy and, if not installed and used in accordance with the instruction manual, may cause harmful interference to radio communications. Operation of equipment in a residential area may cause harmful interference in which case the user will be required to correct the interference at his own expense.



### **WARNING**

CHANGES OR MODIFICATIONS TO EQUIPMENT NOT EXPRESSLY APPROVED BY STAIRMASTER® HEALTH & FITNESS PRODUCTS, INC. COULD VOID THE USER'S AUTHORITY TO OPERATE THIS EQUIPMENT.

## **CANADIAN DOC CLASS A COMPLIANCE**

This digital apparatus does not exceed the Class A limits for radio emissions from digital apparatus set out in the radio interference regulations of the Canadian Department of Communications.

La présent appareil numérique ne dépasse pas les limites établies pour les bruits radioélectriques applicables aux appareils numériques de la Class A prescrites dans les règlements sur le brouillage radioélectrique édicté par le Ministère des Communications du Canada.





## IMPORTANT PHONE NUMBERS

If you need assistance, please have both the serial number of your machine and the date of purchase available when you contact the appropriate StairMaster® Health & Fitness Products, Inc. office listed below.

### OFFICES IN THE UNITED STATES

#### CORPORATE HEADQUARTERS

12421 Willows Road NE, Suite 100  
Kirkland, WA 98034  
(800) 635-2936 or (425) 823-1825  
FAX: (425) 823-9490  
www.stairmaster.com

#### CUSTOMER SERVICE

12421 Willows Road NE, Suite 100  
Kirkland, WA 98034  
(800) 331-3578  
FAX: (425) 814-0601  
E-mail: customerservice@stairmaster.com

### INTERNATIONAL OFFICES AND DISTRIBUTORS

For technical assistance and a list of distributors in your area, please call or fax one of the following numbers.

#### INTERNATIONAL DIVISION

(425) 823-1825  
FAX: (425) 820-7505  
E-Mail: intlservice@stairmaster.com

#### ASIA PACIFIC HEADQUARTERS

Telephone/Fax: +81-45-590-5686  
E-mail: stairintl@aol.com

#### EUROPE: HEADQUARTERS

+41-91-827-3801  
FAX: +41-91-827-8902  
E-Mail: stairmasterch@swissonline.ch

#### GERMANY: HEADQUARTERS

+49-2204/610-27  
FAX: +49-2204/628-90  
E-Mail: stairmaster.de@t-online.de

#### U.K.: HEADQUARTERS

+44-1908/267-345  
FAX: 44-1908/267-346  
E-mail: stairmasteruk@msn.com

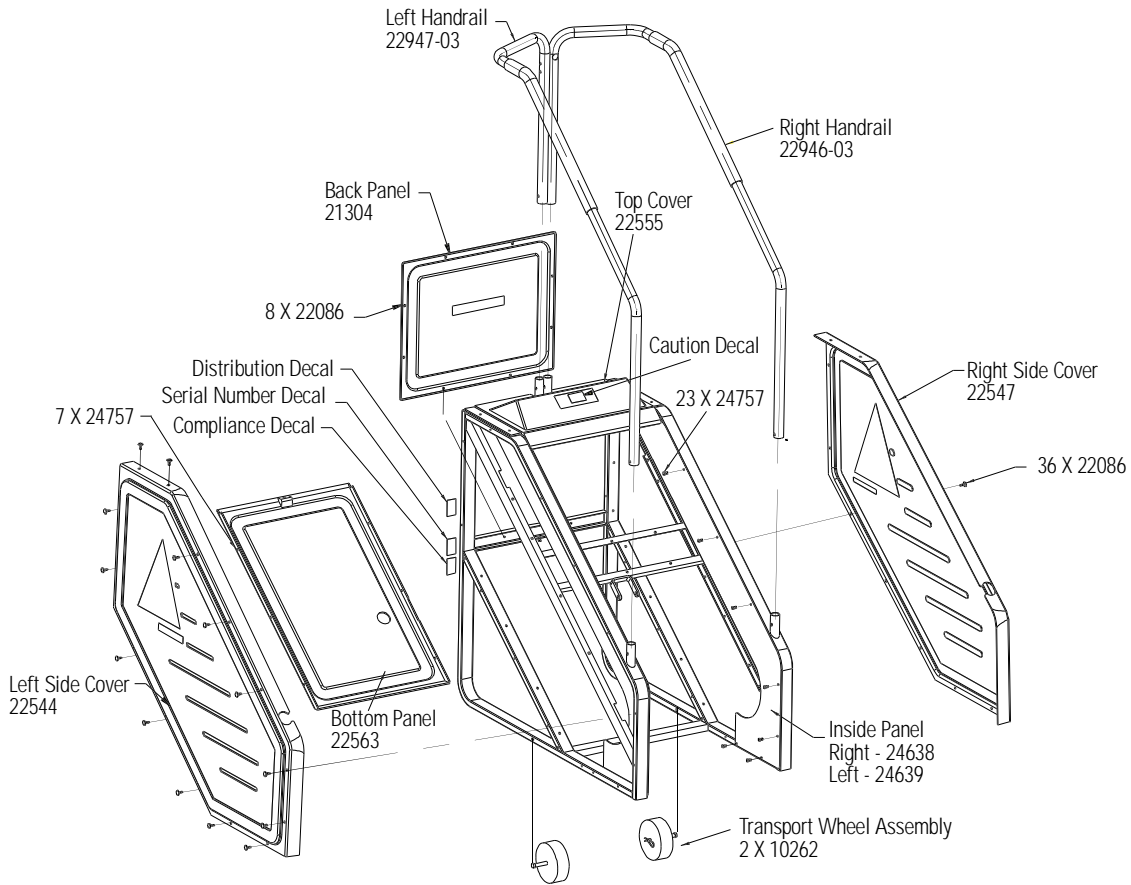

Figure 1: Side Cover and Handrail Assemblies



# FIGURES

## Figure 2: Cover Fasteners

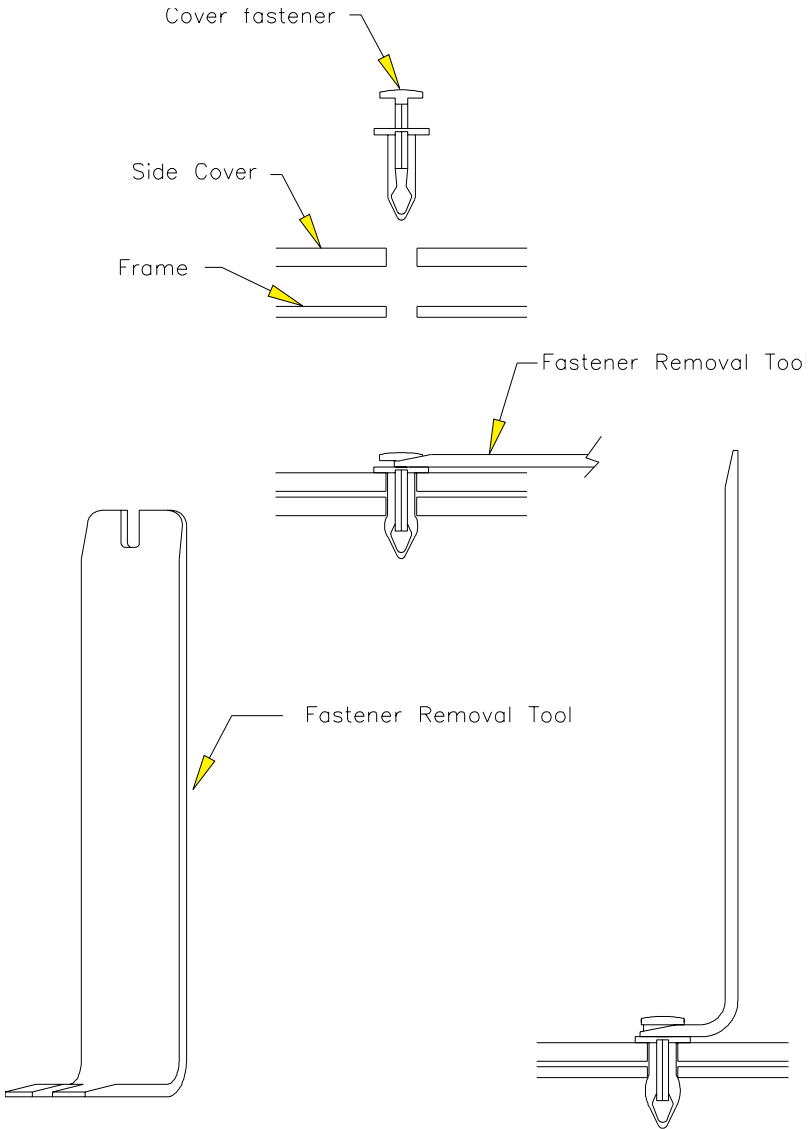

Figure 3: Step Assembly

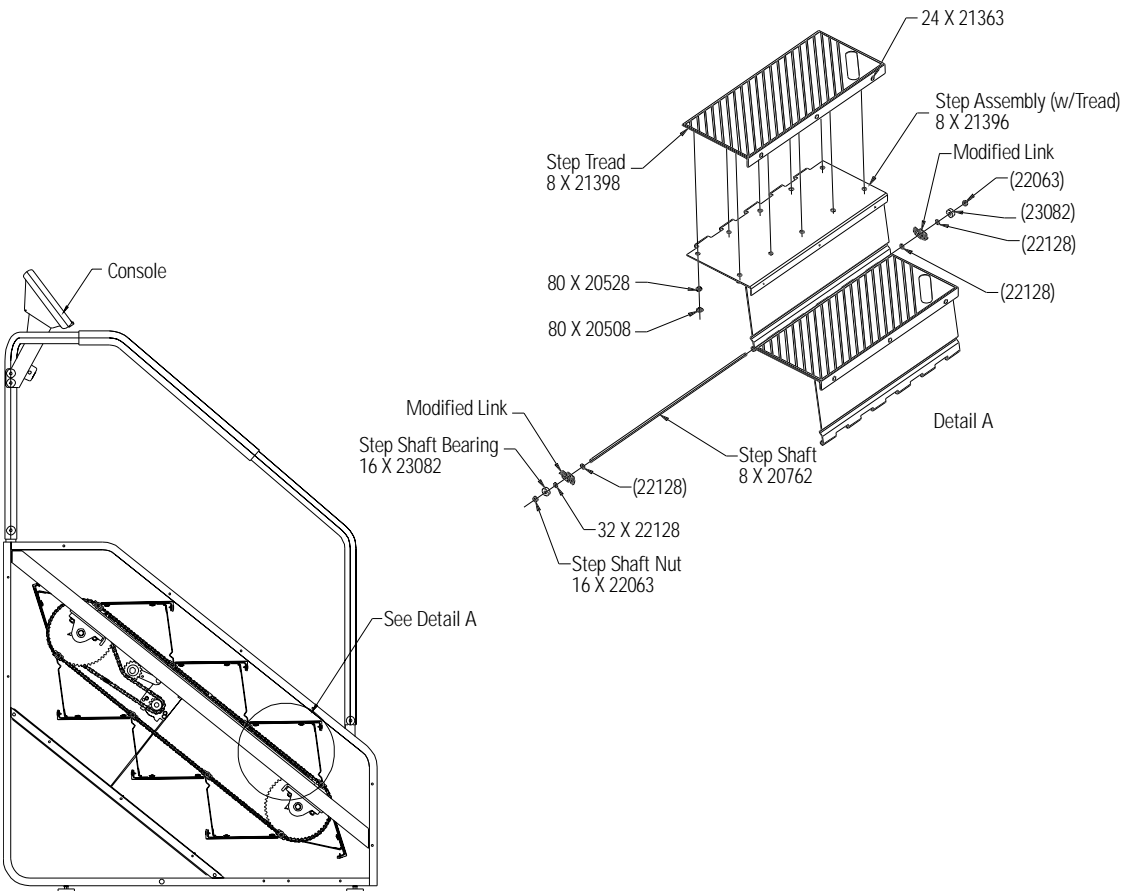
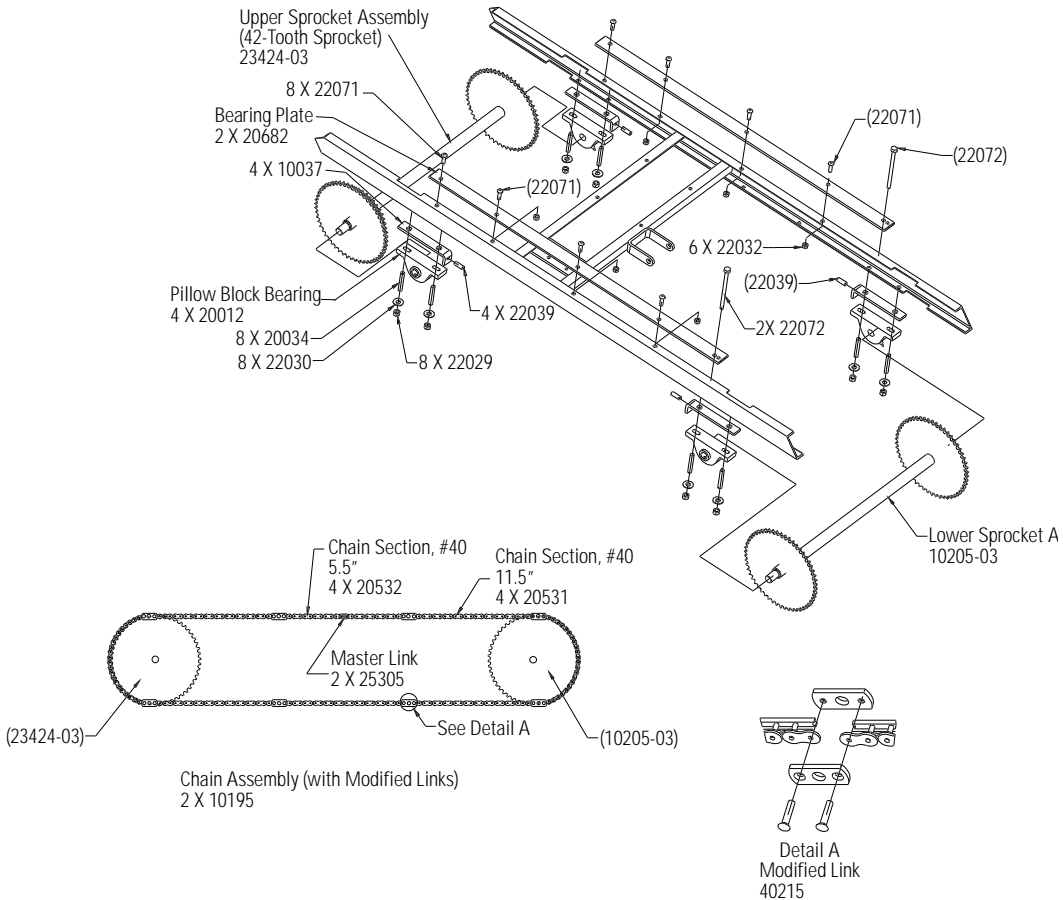
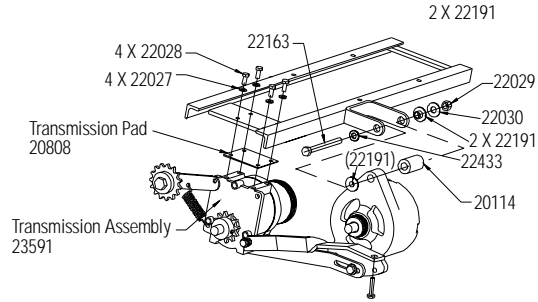

Figure 4: Step Chain and Sprocket Assemblies



**Figure 5: Transmission and Alternator Assemblies**



Transmission Assembly Mounting to the Frame

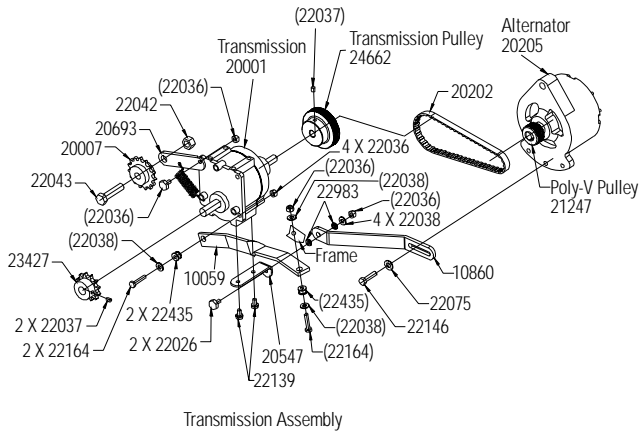

Transmission Assembly

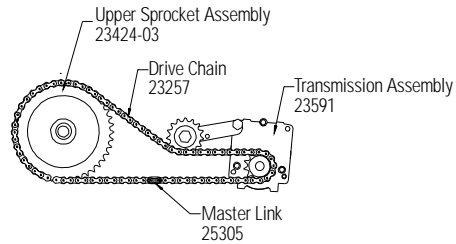

Drive Chain Assembly

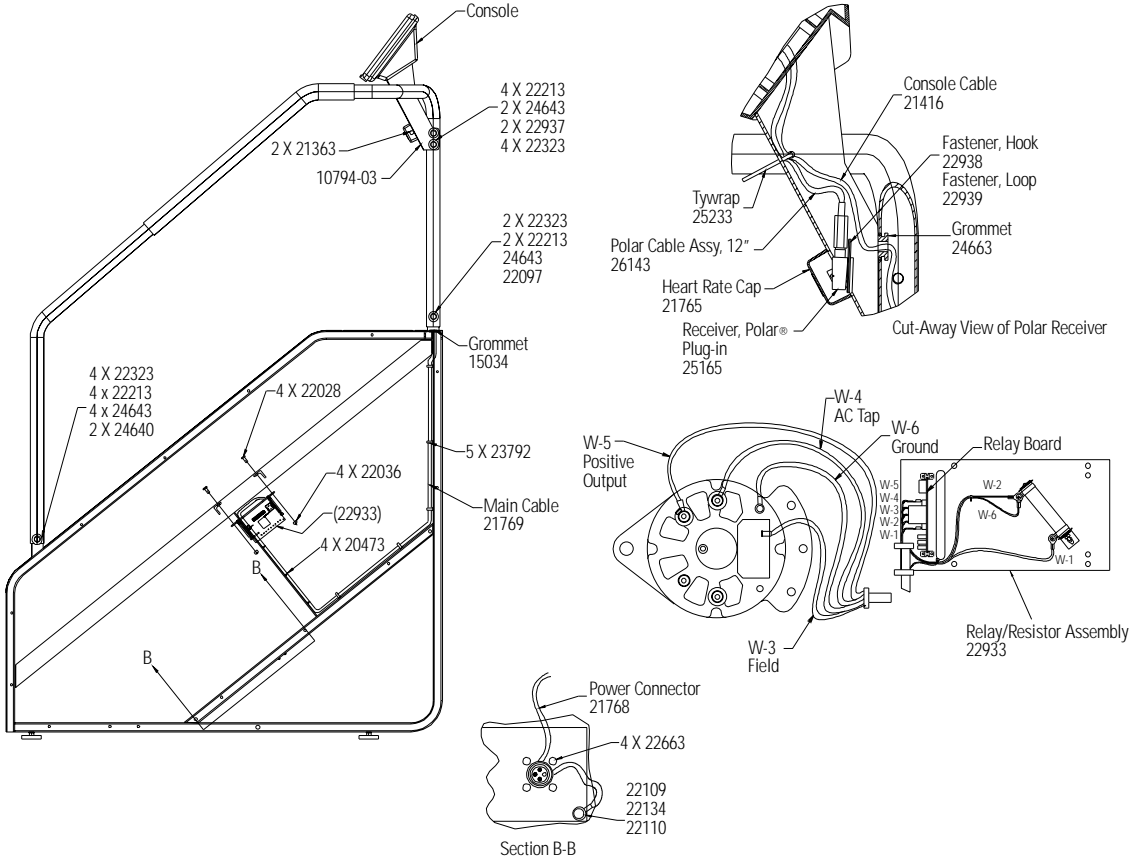
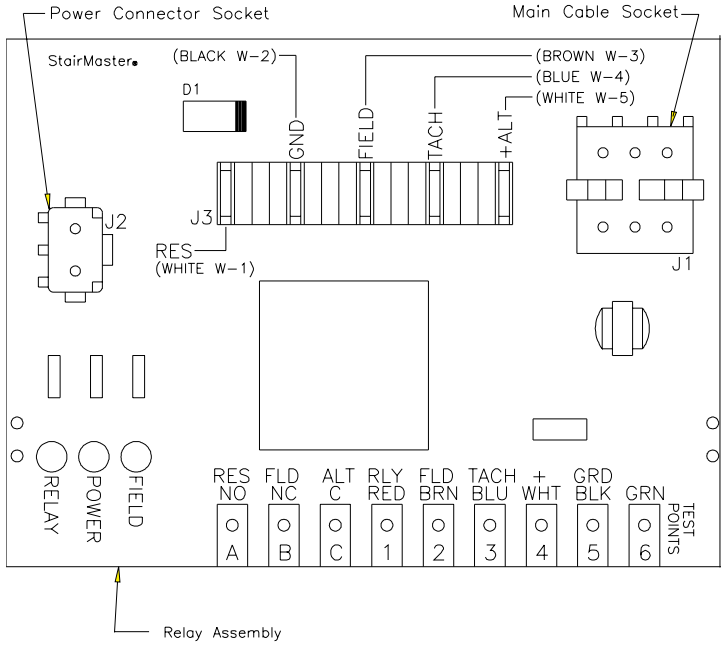

Figure 6: Wiring Diagram

Figure 7: Relay Board







# STePMILL® 7000

## OWNER'S MANUAL



**StairMaster®**  
THE RESULTS YOU WANT™



Printed in the United States.

© 2001 StairMaster® Health & Fitness Products, Inc.

All rights reserved.

**Corporate Headquarters**

12421 Willows Road N.E., Suite 100

Kirkland, WA 98034

(800) 635-2936

(425) 823-1825

Fax (425) 823-9490

[www.stairmaster.com](http://www.stairmaster.com)

**StairMaster®**



**P/N 22869 - A**

© 2001 StairMaster Health & Fitness Products, Inc. StairMaster and Stepmill are registered trademarks or trademarks of StairMaster Health & Fitness Products, Inc. in the United States and/or other countries. All other trademarks are trademarks of their respective companies. StairMaster is a Rutledge Capital company.

## WARRANTY

This is to certify that the StairMaster® Stepmill® 7000 PT exercise system is warranted by StairMaster Health & Fitness Products, Inc. to be free of all defects in materials and workmanship. This warranty does not apply to any defect caused by negligence, misuse, accident, alteration, improper maintenance, or an “act of God”. This warranty is non-transferable from the original owner.

If, within three years from the date of purchase, any part of the StairMaster Stepmill exercise system should fail to operate properly (except any accessories), contact our Customer Service Department to report the problem. When calling, please be prepared to provide the customer service representative with the following information:

- Your name, customer number, shipping address, and telephone number
- The model and serial number of the inoperable machine
- The date(s) of purchase for the inoperable machine(s)
- Your billing address

This information will ensure that you are the only one ordering parts under your warranty protection. If warranty replacement parts are shipped to you, you may be required to return the inoperable part. To facilitate this process, the following policy has been established:

- Please call our Customer Service Department to receive a return materials authorization prior to shipment.
- StairMaster Health & Fitness Products, Inc. will incur all freight charges for warranty parts ordered for a machine that is less than 45 days old. The parts will be shipped to you via an overnight courier.\*
- You are responsible for freight charges on warranty parts for machines that are more than 45 days old. You will not be responsible for the return shipment of the inoperable parts.
- Some inoperable warranty parts must be promptly returned to our Customer Service Department. We will pay the shipping cost for the inoperable warranty parts. Detailed instructions are included with each warranty replacement part.

StairMaster Health & Fitness Products, Inc. neither makes, assumes nor authorizes any representative or other person to make or assume for us, any other warranty whatsoever, whether expressed or implied, in connection with the sale, service, or shipment of our products. We reserve the right to make changes and improvements in our products without incurring any obligation to similarly alter products previously purchased. In order to maintain your product warranty and to ensure the safe and efficient operation of your machine, only authorized replacement parts can be used. This warranty is void if parts other than those provided by StairMaster Health & Fitness Products, Inc. are used.

\* Note: Aerosol products cannot be transported via air.



## PREFACE

The StairMaster® Stepmill® 7000 PT exercise system is a safe, functional, and effective exercise modality for developing aerobic fitness and increasing the strength of the major muscle groups of the lower body. It is designed for use by individuals of all ages and fitness levels. Your purchase of this machine is a positive affirmation of your commitment to use the best available methods for enhancing your functional fitness capabilities. In order to derive optimal benefits from your machine, you should read this manual thoroughly and adhere closely to the instructions.

### **WHAT IS IN THIS MANUAL?**

Following the information on installation and a brief explanation of how the Stepmill 7000 PT exercise system works, this manual contains two major sections. The first section provides an explanation of how the machine should be used to achieve maximum results. The second section offers instructions and advice on how to properly maintain your machine. The "Appendix" contains additional information for the owner.

Throughout this Manual, whenever you are required to enter information into the console, the console keypad keystrokes are enclosed in [ ]. The names of the buttons and special console operational modes are shown in capital letters. For example, your machine is ready for use when the console displays "SELECT WORKOUT." Press the [MANUAL] button to start the MANUAL exercise program.

### **WHAT IS THE STAIRMASTER STEPMILL 7000 PT EXERCISE SYSTEM?**

The StairMaster Stepmill 7000 PT exercise system is a vertical climbing machine with a rotating staircase which provides an aerobic workout equivalent to climbing stairs, without the impact loads and skeletal trauma common to most aerobic activities. Regular use of the Stepmill 7000 PT exercise system strengthens and conditions the heart and the following lower body muscle groups: gluteals, quadriceps, hamstrings, and calf muscles.



# CONTENTS

<b>SAFETY GUIDELINES .....</b>	<b>1</b>
<b>INSTALLATION INSTRUCTIONS .....</b>	<b>3</b>
<b>BASIC OPERATING INSTRUCTIONS .....</b>	<b>6</b>
General Guidelines for Safe Operation .....	6
Your First Workout on the StairMaster® Stepmill® 7000 PT Exercise System .....	7
Basic Instructions for First-Time Users .....	7
Rest periods .....	8
<b>HEART RATE MONITORING .....</b>	<b>10</b>
Locked/Non-Locked Option .....	10
Error Messages .....	11
<b>TELEMETRY (POLAR®) HEART RATE .....</b>	<b>12</b>
Using the Transmitter Belt .....	12
Maintaining the Transmitter Belt .....	13
<b>7000 PT CONSOLE .....</b>	<b>14</b>
The Display Window .....	14
The Numeric Keypad .....	15
The Entertainment Keypad .....	15
The Intensity Level Keys .....	15
The Stop Key .....	15
The Workout Statistics .....	16
The Exercise Program Keypad .....	17
The Quick Start Option .....	17
The Manual Program .....	17
The Fat Burner Program .....	18
The Aerobic Training Program .....	18
The Speed Intervals Program .....	18
The Constant Heart Rate Program .....	19
The Fitness Test Programs .....	20
Understanding Submaximal Exercise Testing .....	20
Pretest Screening .....	22
The StairMaster Submaximal Fit Test .....	22
The Firefighter's Stair Climb Tests .....	25

# CONTENTS

Turning the CPAT Stair Climb Test on .....	26
Turning the NYCFD Stair Climb Test on .....	26
Console Codes .....	27
<b>MAINTENANCE INSTRUCTIONS .....</b>	<b>31</b>
Helpful Hints .....	31
Tool List .....	31
Maintenance Records .....	31
Initial Service .....	32
Preventative maintenance .....	32
Cleaning and Inspecting .....	32
Lubrication .....	33
<b>TROUBLESHOOTING .....</b>	<b>36</b>
General Troubleshooting Guidelines .....	36
Troubleshooting the Electrical System .....	36
The Console Fails to Power Up .....	36
Console Diagnostics Tests .....	39
The Display Test .....	39
The Keypad Test .....	39
The Serial Port test .....	40
The Alternator Test .....	40
The Tach Test .....	41
Error Reporting .....	41
The Telemetry (Polar®) Heart Rate Test .....	42
Speed Control Problems .....	43
Load Resistor Test .....	47
Troubleshooting the Drive Train .....	48
<b>PARTS REMOVAL AND REPLACEMENT .....</b>	<b>51</b>
Covers .....	51
Side Covers .....	51
Top Cover .....	51
Back Cover .....	52
Bottom Cover .....	52
Console .....	52
Poly-V Belt .....	53
Drive Chain .....	53

# CONTENTS

Step Assembly .....	54
Step Chain Assembly .....	55
Upper (and Lower) Sprocket Assembly .....	57
Cable Assembly .....	59
Transmission Assembly .....	60
Alternator Assembly .....	61
Relay/Resistor Assembly .....	62

<b>GROUNDING INSTRUCTIONS .....</b>	<b>64</b>
-------------------------------------	-----------

<b>FCC COMPLIANCE .....</b>	<b>65</b>
-----------------------------	-----------

<b>CANADIAN DOC CLASS A COMPLIANCE .....</b>	<b>65</b>
--	-----------

## APPENDICES

Important Phone Numbers .....	66
Figures 6 - 12 .....	67

## LIST OF TABLES

Table 1. Dimensions and Specifications for the StairMaster® 7000 PT Exercise System .....	3
Table 2. Fitness Rating Norms .....	14
Table 3. Recommended Preventive Maintenance Schedule .....	35

## LIST OF ILLUSTRATIONS

Figure 1: Correct Exercise Position .....	9
Figure 2: Transmitter Belt .....	13
Figure 3: The Stepmill 7000 PT Console .....	14
Figure 4: StairMaster Fitness Protocol .....	24
Figure 5: Grounding System .....	64
Figure 6: Side Cover and Handrail Assemblies .....	67
Figure 7: Cover Fasteners .....	68
Figure 8: Step Assembly .....	69
Figure 9: Step Chain and Sprocket Assemblies .....	70
Figure 10: Transmission and Alternator Assemblies .....	71
Figure 11: Wiring Diagram .....	72
Figure 12: Relay Board .....	73

# SAFETY GUIDELINES

WHEN USING ELECTRICAL EQUIPMENT, ALWAYS FOLLOW THESE BASIC PRECAUTIONS:

## IMPORTANT SAFETY INSTRUCTIONS



This symbol appearing throughout this manual means Attention! Be Alert! Your safety is involved.

The following definitions apply to the words "Danger" and "Warning" found throughout this manual:

**DANGER** - Used to call attention to IMMEDIATE hazards which, if not avoided, will result in immediate, serious personal injury or loss of life.

**WARNING** - Used to call attention to POTENTIAL hazards that could result in personal injury or loss of life.

### READ ALL INSTRUCTIONS BEFORE USING THE MACHINE.



#### **DANGER**

To reduce the risk of electrical shock, always unplug the external power supply from the AC wall outlet before cleaning, maintaining, or repairing.



#### **WARNING**

To reduce the risk of burns, electric shock, or injury to persons:

1. The external power supply should always be unplugged from the AC wall outlet before removing or installing parts. Never make adjustments or repairs while an exercise program is in progress.
2. Close supervision is necessary whenever the machine is used by or near children, invalids, or disabled persons.
3. Keep your hands away from all moving parts and keep your feet on the pedals while exercising. Do not operate the machine with the side covers removed.





## SAFETY GUIDELINES

4. Use this machine only for its intended use as described in this Manual. Do not use parts, attachments, or accessories other than those provided by StairMaster® Health & Fitness Products, Inc.
5. Do not use the external power supply if it has a damaged cord or plug, or if it is not working properly, if it has been dropped or damaged, or dropped into water. Contact our Customer Service Department at 1-800-331-3571 to arrange for the return of damaged parts.
6. Connect the external power supply to a properly grounded AC wall outlet; refer to the “Grounding Instructions” section. Keep all cords away from heated surfaces.
7. To disconnect the external power supply, remove the plug from the AC wall outlet.
8. Never drop or insert any object into any opening on the machine.
9. Do not operate where aerosol (spray) products are being used.
10. Always wear insulated gloves when handling batteries.
11. Do not use the machine outdoors.

The safety level given by the design of this equipment can only be maintained when the equipment is regularly examined for damage and wear. Inoperable components shall be replaced immediately or the equipment shall be put out of use until it is repaired. Failure to follow all guidelines may compromise the effectiveness of the exercise experience, expose yourself (and possibly others) to injury, and reduce the longevity of the machine. Follow all training instructions listed in the manual and/or on the machine. Physical injury may result from incorrect or excessive training.

**SAVE THESE INSTRUCTIONS**

# INSTALLATION INSTRUCTIONS

Before leaving the manufacturing facility in Tulsa, Oklahoma, your StairMaster® Stepmill® 7000 PT exercise system was thoroughly inspected and tested for proper operation. To minimize shipping damage, careful attention was given to making your machine ready for shipment.

The dimensions of the machine are listed in Table 1. Throughout this manual, all references to the left or right side and to the front or back are made as if you were on the machine, ready to exercise.

**Table 1. Dimensions and Specifications for the StairMaster 7000 PT Exercise System**

<b>Physical Dimensions:</b>	
Length	50.0 inches (127 cm)
Width	29.0 inches (74 cm)
Height	78.0 inches (198 cm)
Weight	409 pounds (186 kg)
<b>Power Supply Specifications:</b>	
Output Voltage	12 to 19 VDC
Output Current Capacity	2.5 amps
Input Power Consumption	55 watts

The machine requires minor assembly before operation. You will need a pair of diagonal cutters or a pair of heavy-duty scissors. The Stepmill 7000 PT exercise system must be placed on a solid, level floor near an AC wall outlet. A minimum ceiling height of 9 feet (2.8 meters) and a doorway width of 29 inches (74 cm) is required.

1. Roll the machine to its desired location on its temporary wheels.
2. Have an assistant tilt the machine forward until the wheels are off the floor. Make sure the assistant can support the machine so you can remove the temporary wheels.

## INSTALLATION INSTRUCTIONS

- Remove the clevis pin from each wheel (See Drawing Below) and remove the wheels from the frame.

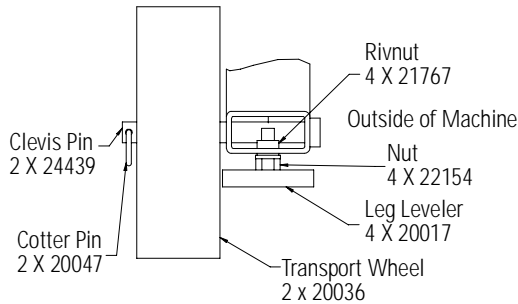

- Help your assistant lower the machine to the floor. Install and adjust the leg levelers as necessary to level the machine (see Above).
- If your machine was shipped outside North America, it will need additional assembly (if this is not the case, skip to step #6).
  - Use the fastener removal tool to remove the 8 fasteners on the back panel.
  - Mount both handrails onto the frame as shown in Figure 6.
  - Push the console cable assembly through the grommet in the frame and connect it to the main cable assembly (refer to Figure 6).
  - Install the console mount onto the handrails (refer to Figure 6).
  - Install the console and connect the console cable.
  - Reinstall the back panel and go to step #6.
- Unwrap the power supply assembly from the console and connect the DC power cable from the power supply to the power connector located on the bottom cover.
- Place the power supply on the floor near an AC wall outlet. To reduce the hazard of electrical shock, place the power supply in a location away from the machine and away from exposure to perspiration. You should not place your power supply on a carpet because it may overheat.
- Check to be sure that the input AC power rating marked on the power supply matches the available power. If it does not, obtain the matching power supply from StairMaster® Health & Fitness Products, Inc. before proceeding any further.

# INSTALLATION INSTRUCTIONS



## WARNING

TO REDUCE THE RISK OF ELECTRICAL SHOCK AND FIRE AND TO PREVENT SEVERE DAMAGE TO THE MACHINE, USE ONLY THE POWER SUPPLY APPROVED FOR USE WITH THIS EQUIPMENT. IN ADDITION, YOUR MACHINE MUST BE PROPERLY GROUNDED.

9. Connect the AC power cord to the AC wall outlet. Refer to the “Grounding Instructions” section of the Manual if the AC wall outlet does not accept a three-prong plug.
10. Watch the console. The console should display a software revision code and then show “SELECT WORKOUT.” If it does not, unplug the power supply and then plug it back in. If the sound and/or the display are still not present, contact the Customer Service Department at 800-331-3578. International customers should call their local distributor; refer to the Appendix for the phone number of the office nearest you.
11. When the console displays “SELECT WORKOUT”, your Stepmill® 7000 PT exercise system is ready to use.
12. Custom-length DC cables and other accessories are available. Refer to the Appendix for the phone number of the office nearest you.

# BASIC OPERATING INSTRUCTIONS

## GENERAL GUIDELINES FOR SAFE OPERATION



### WARNING

THESE GUIDELINES ARE DIRECTED TO YOU, AS THE OWNER OF THE MACHINE. YOU SHOULD INSIST THAT ALL USERS FOLLOW THE SAME GUIDELINES. YOU SHOULD MAKE THIS MANUAL AVAILABLE TO ALL USERS.

1. Obtain a complete physical examination from your medical doctor and enlist a health/fitness professional's aid in developing an exercise program suitable for your current health status.
2. When working out for the first time, use the MANUAL exercise program at the lower speeds until you feel comfortable and capable of faster speeds.
3. The speed and duration of your exercise program should always be subject to how you feel. Never permit peer pressure to exceed your personal judgment while exercising.
4. Overweight or severely deconditioned individuals should be particularly cautious when using the machine for the first time. Even though such individuals may not have histories of serious physical problems, they may perceive the exercise to be far less intense than it really is, resulting in the possibility of overexertion or injury.
5. Although all equipment manufactured by StairMaster Health & Fitness Products, Inc. has been thoroughly inspected by the manufacturing facility prior to shipment, proper installation and regular maintenance are required to ensure safety. Maintenance is the sole responsibility of the owner.

# BASIC OPERATING INSTRUCTIONS

## YOUR FIRST WORKOUT ON THE STAIRMASTER® STEPMILL® 7000 PT EXERCISE SYSTEM

### Basic Instructions for First-Time Users

1. Warm up with light calisthenics and easy stretching exercises for at least five minutes before beginning your exercise program.



### WARNING

IF AT ANY TIME DURING YOUR WORKOUT YOU FEEL CHEST PAIN, EXPERIENCE SEVERE MUSCULAR DISCOMFORT, FEEL FAINT, OR ARE SHORT OF BREATH, STOP EXERCISING IMMEDIATELY. IF THE CONDITION PERSISTS, YOU SHOULD CONSULT YOUR MEDICAL DOCTOR IMMEDIATELY.

2. Hold onto the handrails and step up onto the staircase. Stand up straight. The steps will rotate slowly.
3. Select the MANUAL exercise program so you can control the pace of your first workout and get used to the exercise motion.
4. Press [MANUAL] and then [ENTER]. The console will return to the start screen if you do not press [ENTER] within ten seconds.
5. The console will prompt you to enter your body weight. Enter your weight in pounds (or kilograms if the console is set up for metric units). Correct entry errors by pressing [CLEAR] before you press [ENTER].
6. The console will prompt you to enter the workout time in one-minute increments between five and 99 minutes. Press [1], [0], [ENTER] to exercise for ten minutes.
7. Step up with one foot at a time. Try to stay towards the top of the staircase. As you become comfortable with exercise motion, press [LEVEL: ^] and [LEVEL: v] to adjust your climbing speed.



## **BASIC OPERATING INSTRUCTIONS**

8. Relax as much as possible while exercising and maintain an erect posture. Use the handrails for balance. Don't lock your elbows or lean on the console. Supporting your weight will reduce the exercise intensity and the console will overestimate the number of calories burned.
9. Select a speed (or intensity level) that allows you to step towards the top of the staircase. Faster is not always better. Exercise at a level that is consistent with your fitness level.

### **Rest Periods**

10. You can stop and rest as many times as necessary for up to one minute for each rest period during all programs. To stop, either press [STOP] or step off the machine. The console returns to the start screen if you rest longer than the allotted rest period. Follow the onscreen prompt to continue your work out after a rest period.

### **Cool Down**

11. When you are finished with your workout, the machine will slow down and the message "GOAL ATTAINED" will be displayed. You can cool down on the machine by continuing to step. The console timer will continue to count up from the selected time, and the intensity level will default to level 3. If there is a time limit set on the console, the timer will last only until the maximum time has been met. For example, if the time limit was set for 30 minutes and you worked out for 25 minutes, the cool down period would last for 5 minutes, or until you stepped off the machine.
12. You can also cool down by getting off the machine walking or stretching for at least five minutes.

# BASIC OPERATING INSTRUCTIONS

Figure 1: Correct Exercise Position

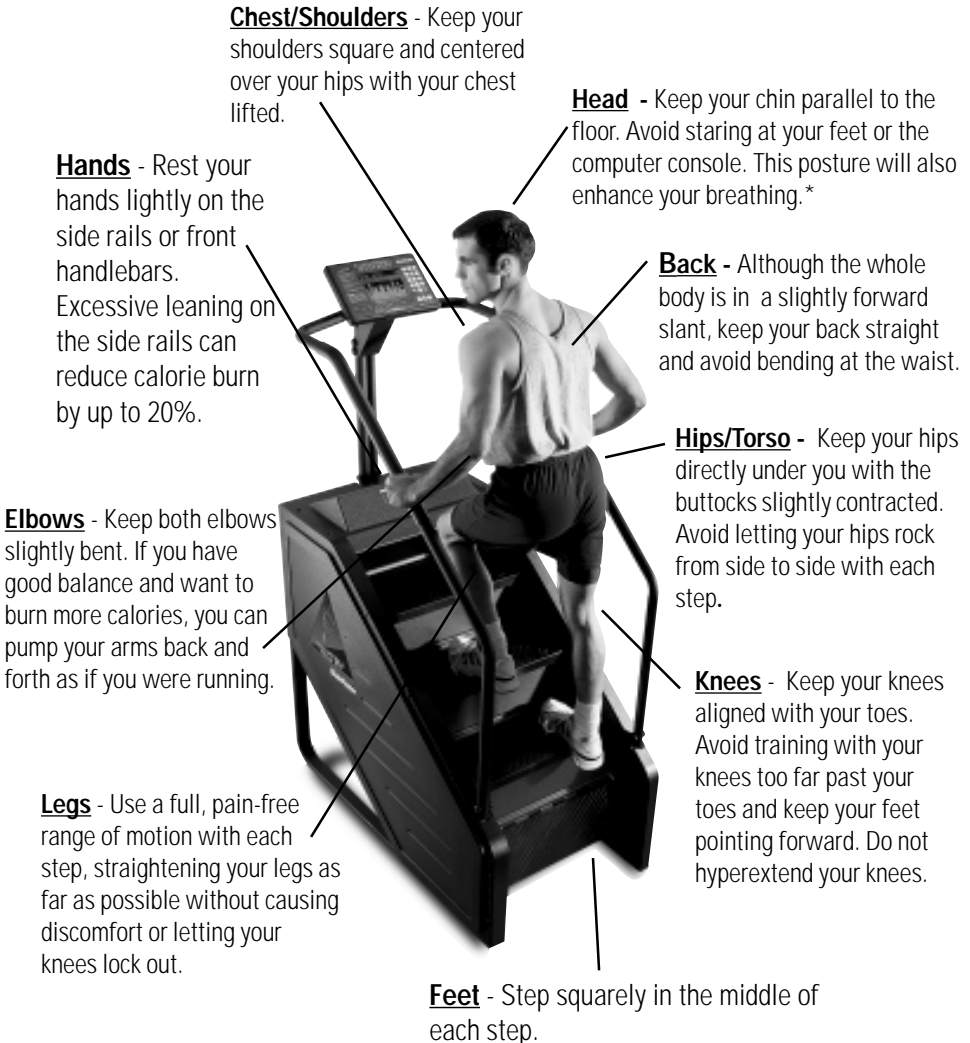

*\*Please note that in the photo the person has his head turned - keep your head facing forward as you exercise.*





# HEART RATE MONITORING

## HEART RATE INPUT

The 7000 PT console uses telemetry (e.g., Polar®) heart rate signal detection. Ensure that your console is set up for telemetry signal detection only. There is a short “lock out” period at the beginning of each workout session during which the console first detects a signal and then validates the signal type.

- Telemetry heart rate - after the initial belt signal is detected, the console will enter a validation phase in which four good heart beat signals within four seconds are required before locking on telemetry heart rate signals for the duration of the workout session. During the validation phase the console will not recognize contact heart rate signals.

### Locked/Non-locked Option

When the “not locked” option is selected the heart rate source signal is not fixed during the exercise (if the signal is lost either input will be valid). If the “locked” option is selected then the heart rate source signal is locked on the first detected signal during the workout. To set a heart rate signal input, or to turn off the heart rate option all together, perform the following steps:

1. On the console keypad, press [LEVEL: ^], [3], [2]. At this point the screen will display “HR INPUTS.” Press [ENTER] to select this option.
2. There are 4 options to handle heart rate input signals. Only 2 of those options are appropriate for the 7000 PT; “Both HR Off”, and “Telemetry Only.” Press the [SELECT] key to scroll past the other options until you find either “Both HR Off” or “Telemetry Only.” Press the [ENTER] key to select the desired option.



## HEART RATE MONITORING

**“TELEMETRY ONLY”** - locks out contact heart rate signals and will only detect telemetry signals. Set your console to this default.

**“BOTH HR OFF”** - turns off the ability to detect any signal at all. Used in rare situations where there is excessive interference with the heart rate signals. This option turns off disables the Constant HR program and the Fitness Test program.

### Error Messages

Text line messages are only seen in the Constant Heart Rate and Fitness Test programs due to the design of the program that necessitates a valid heart rate signal at all times during the program.

**“CHECK HR BELT ”** - The heart rate signal has been missing for the last 30 seconds in telemetry signal detection.

**“HR BELT NEEDED”** - No telemetry belt signal been sensed during the initial setup time.

**“HR MODE DISABLED”** - No heart rate signal is allowed due to the set up option that was chosen. Heart rate monitoring is not possible.

# TELEMETRY HEART RATE

## TELEMETRY HEART RATE

The StairMaster® Stepmill® 7000 PT features telemetry (Polar®) heart rate monitoring. The system consists of the receiver, located on the stepper, and a transmitter belt (purchased separately) worn across your chest. The monitoring function is activated as soon as you strap on the chest belt and step within range of the receiver in the machine. Two electrodes on the underside of the chest belt sense the heart rate signal and send it to the receiver. The heart symbol on the console pulses to indicate that the console is receiving a valid signal. A microprocessor in the console calculates the heart rate and displays it, in beats per minute, on the console.

### Using the Transmitter Belt



#### **WARNING**

**PACEMAKER USERS SHOULD NOT USE THE POLAR TRANSMITTER BEFORE CONSULTING THEIR DOCTOR.**

Before you put the transmitter belt on, wet the two electrode patches (the grooved rectangles on the reverse side of the belt). Secure the transmitter belt as high under the pectoral muscles (chest) as is comfortable. The transmitter belt should fit snugly and comfortably, and allow normal breathing. When the console detects a heart rate signal, heart rate is shown in the display automatically. Your heart rate in beats per minute and a pulsing heart icon are displayed on the console.

After the initial belt signal is detected, the console will enter a validation phase in which four good heart beat signals lasting four seconds each are required before locking on telemetry heart rate signals for the duration of the workout session. During the validation phase the console will not recognize contact heart rate signals. If you do not see a heart rate on the console, try one of the following:

- Move closer to the console.

## TELEMETRY HEART RATE

- Tighten the elastic part of the chest belt.
- Adjust the belt higher or lower on your chest.
- Remoisten the electrodes.
- Test your chest strap with a machine that you know is working, or with a heart rate watch that you know is working.
- If possible, replace or exchange your console with a console (from the same type of machine) that you know is working and retest the machine.
- Visually check that the heart rate receiver is positioned correctly in the neck cover. The heart rate receiver jack should point down. Ensure that the heart rate receiver is connected to the console, and that the connection is not loose. If possible, swap the heart rate receiver with one from another machine.

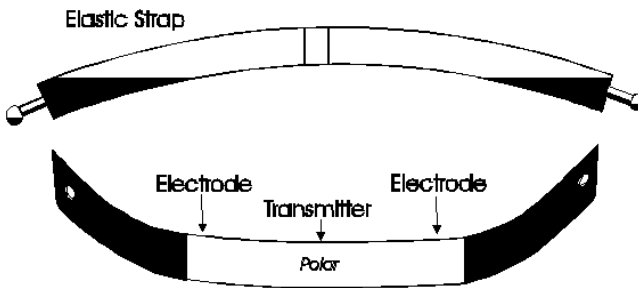

**Figure 2: Transmitter Belt**

### Maintaining the Transmitter Belt

Clean the chest belt regularly with mild soap and water, then dry thoroughly - residual sweat and moisture keep the transmitter active and drain the battery in the transmitter. Do not use abrasives or chemicals such as steel wool or alcohol for cleaning, as they can damage the electrodes permanently. You can order replacement belts from StairMaster, Polar Electro, Inc., or your local fitness store:

StairMaster	800-331-3578	P/N 64000
Polar Electro, Inc.	800-227-1314	

## 7000 PT CONSOLE

The StairMaster® Stepmill® 7000 PT exercise system console is divided into seven sections: the display window, the workout options, the numeric keypad, the entertainment keypad, the workout statistics, the stop key, and the intensity level keys (see Figure 3).

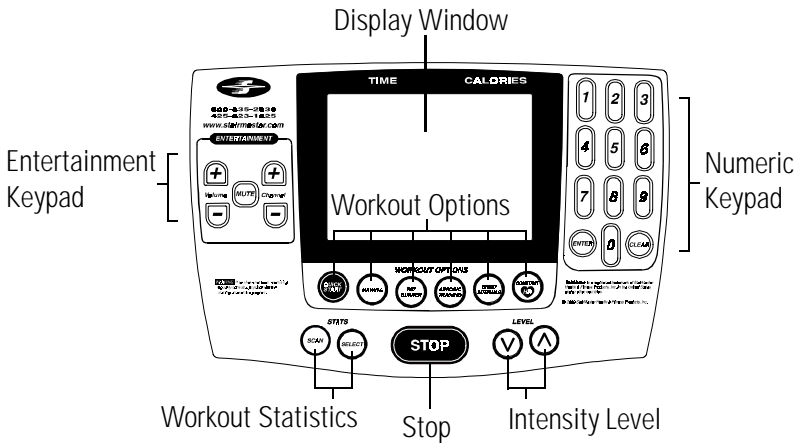

Figure 3: The Stepmill 7000 PT Console

### THE DISPLAY WINDOW



- **Time** - The selected workout time is displayed in the upper left section of the display window. Once the time is entered, the timer will count down, in minutes and seconds, until the workout is finished or stopped. If [0] is entered in the MANUAL or CONSTANT HEART RATE program, the timer will count up.
- **Calories** - The real-time amount of calories burned is continually updated and displayed in the upper right section of the display window.
- **Interval Timer** - The interval timer is displayed below the Time. The interval timer counts down time left within each interval.
- **Heart Rate** - Current heart rate is displayed below the Calories, next to the heart icon.
- **Workout Option Profile** - A profile of the selected exercise program appears in the lower section of the display window during a workout. The taller the column, the higher the intensity (watts) for that interval. The flashing column shows your current interval. The flashing column moves from left to right across the display as you complete each interval.

## THE NUMERIC KEYPAD

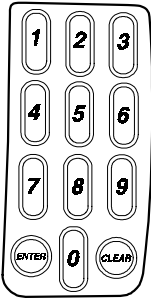

The numeric keypad is located on the right side of the console. Before the exercise program begins, the numbers are used to enter data in response to the console prompts.

- **Enter** - Confirms workout selections and stores the information used by the console to calculate workout statistics.
- **Clear** - Erases information from the console memory if pressed before [ENTER].

## THE ENTERTAINMENT KEYPAD

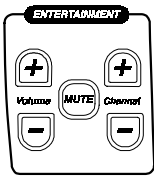

The FreeClimber comes equipped to facilitate the use of commercial entertainment systems. Using any of these keys will send an output signal through the Communication Specification for Fitness Equipment (C.S.A.F.E.) port to a connected C.S.A.F.E. or compatible system. If a system is not connected, pressing these keys will have no effect.

- **Volume Up/Down** - Increases or decreases the volume level of the audio source.
- **Mute** - Removes the audio sound from the headphones.
- **Channel Up/Down** - Changes the channel of the commercial entertainment system.

## THE INTENSITY LEVEL KEYS



The exercise intensity level may be changed at any time during a workout. Pressing the [∨] key decreases the intensity and pressing the [∧] key increases the intensity.

## STOP KEY



Press the [STOP] key any time you want to pause the exercise program for up to one minute. Press [STOP] a second time, or [1], and The console will return to the "SELECT WORKOUT" Prompt.

# 7000 PT CONSOLE

## THE WORKOUT STATISTICS

During the exercise program, the Stats keys are used to track workout statistics which are then shown in the display window. Pressing the [SELECT] key turns off the scanning feature and shows the statistic of choice in the display window. Pressing the [SCAN] key will prompt the console to cycle through the following statistics:

- **Distance** - Provides a cumulative total of the equivalent distance (in miles or kilometers), you would have traveled while riding a bicycle outdoors at the same relative intensity.
- **Calories/Hour** - Provides a running total of the number of calories burned during a workout.
- **Rate** - Displays the current steps per minute.
- **Floors** - Displays the equivalent number of floors climbed with an 8-inch step. There are 16 steps per floor, and 48 floors per mile.
- **Level** - Shows the current intensity level between 1 (the easiest) and 20 (the hardest).
- **Watts** - Displays the exercise intensity in watts (746 watts = 1 horsepower).
- **METs** - Gives you the relative energy cost of exercise. MET stands for multiples of the resting metabolic rate. While you are sitting quietly, your body consumes oxygen at the rate of about 3.5 milliliters per kilogram of body mass per minute. When you exercise, your body needs more oxygen in order to function. For example, exercising at 10 METs requires ten times the resting rate of oxygen consumption, or about 35 milliliters per kilogram per minute. During a workout, this key shows the current MET level. During the workout summary, the average MET level is displayed.
- **Target Heart Rate** - Available only during the Constant Heart Rate program. Shows the selected target heart rate.

At the completion of a workout, the statistic averages are calculated based on the accumulation of data during the workout program, and not including the cool down period.

## THE EXERCISE PROGRAM KEYPAD

The exercise keypad is located below the display and to the left of the function keypad. While the console is in the "SELECT WORKOUT" mode, press one of the exercise program keys to preview the desired workout. There are six workout programs with the following standard defaults (pressing [ENTER] without inputting data first will prompt the console to enter these values):

- **Weight** - 175 lbs.
- **Intensity Level** - 3
- **Workout Time** - The default time in the programmed workouts and Quick Start is 20 minutes. The Manual and Constant Heart Rate programs do not have a specified default time. In these programs, the console timer will count up to the maximum time of 99 minutes, and then return to 0.
- **Age** (Constant Heart Rate program only) - 40 years

Once you have selected a program, the prompts are:

- "**ENTER BODY WEIGHT**" - type in your body weight in pounds (or kilograms if your console is set to metric units).
- "**ENTER LEVEL 1 - 20**" - select your intensity level with level 1 being the easiest and level 20 the hardest.
- "**ENTER TIME 5 - 99**" - select the workout duration in one minute increments from 5 to 99. Press 0 in the MANUAL and CONSTANT HEART RATE program to workout for an unspecified amount of time.

### The Quick Start Program

Provides an immediate start, without having to enter any user information. This program uses the standard default settings for derivation of calories burned.

### The Manual Program

After pressing the [MANUAL] key, enter user and workout information. Begin exercising at the selected level. If desired, adjust the workout manually by using the intensity level arrow keys. The profile in the display window is divided into 15 equal intervals within the workout time. The profile is based



## 7000 PT CONSOLE

on the selected intensity level, with 2 levels equating to one vertical bar.

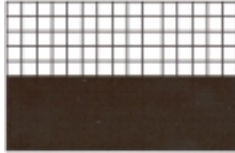

### The Fat Burner Program

The Fat Burner program is a 60-interval workout designed for people just starting a weight control program. The relative intensity level is indicated on the profile and any changes in the intensity level will continue for the remainder of the program.



### The Aerobic Training Program

The Aerobic Training program is a 60-interval workout designed to increase aerobic capacity. The relative intensity level is indicated on the profile and any changes in the intensity level will not change the look of the remaining profile.



### The Speed Intervals Program

The Speed Intervals program is a workout with 8-rest intervals and 7-exercise intervals that alternate speed/intensity level changes. You can change the REST interval speed/level and the EXERCISE interval speed/level independently, using the level keys. For example, if you decrease the intensity level during a rest interval then subsequent rest intervals will be the same. However, the EXERCISE interval remains at the same intensity level you started with. To change the intensity level of the EXERCISE interval, you must change the intensity level

during an EXERCISE interval. The intensity level shown during an EXERCISE interval is indicative of your current speed. However, the current speed during a REST interval is equal to a scaled percentage of the displayed intensity level. Note that the program profile does not change at any time during the workout session.

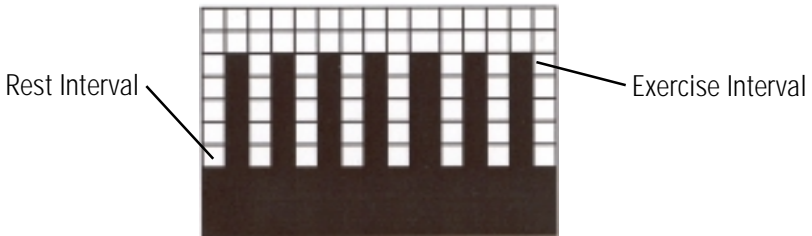

### The Constant Heart Rate Program

The Constant Heart Rate program maintains a chosen target heart rate by automatically varying the climbing speed during each workout. The default target heart rate is equal to 70% of your maximum heart rate which is calculated by the following equation:  $220 - (\text{Age}) \times .70$ . Choose a different target heart rate (between 80 and 180 beats per minute) at any time during the workout by using the numeric keypad to enter the new target heart rate, followed by the [ENTER] key. The following messages may be shown during a workout:

- **"CHECK HR BELT"** - The heart rate signal has been missing for the last 30 seconds in telemetry signal detection.
- **"HR BELT NEEDED"** - No telemetry belt signal has been sensed during the initial setup time.
- **"HOLD HR SENSORS"** - In contact heart rate signal situations this message will come every 30 seconds to prompt the user to hold the sensors.
- **"HR MODE DISABLED"** - No heart rate signal is allowed due to the set up option that was chosen. Heart rate monitoring is not possible.

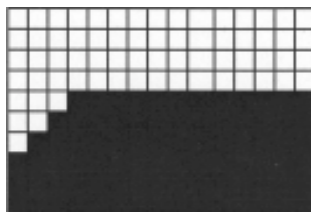

# 7000 PT CONSOLE

## The Fitness Test Programs

### Understanding Submaximal Exercise Testing

Before using the StairMaster FreeClimber for submaximal exercise testing, it should be noted that all submaximal fitness tests make several assumptions:

- That a steady-state heart rate is obtained for each exercise workload.
- That a linear relationship exists between heart rate, oxygen up take and workload.
- That the maximal heart rate for a given age is uniform.
- That the mechanical efficiency of the physical activity performed (i.e., oxygen uptake at a given workload) is the same for every one.

It should be kept in mind that any one or all of the above mentioned assumptions may not be met during a submaximal exercise test. If for any reason one of the assumptions is not met, then errors in predicting  $VO_{2\max}$  will occur.

Unfortunately, it is often quite difficult to meet all of the requirements for the four listed assumptions. For example, exercising at a given workload for only a few minutes can involve an insufficient amount of time for many individuals to achieve a true steady-state. To ensure that a steady-state has been achieved, the heart rate should be measured after two minutes of exercise at a given workload and again after the third minute of exercise at that workload. These two heart rates should then be compared. If a difference of more than five beats per minute between the two is found, the subject should continue to exercise at one-minute intervals at the same workload until two successive heart rates differ by less than five beats per minute.

It is also important that the submaximal heart rates obtained be between 115 and 150 beats per minute, because it is within this heart rate range that a linear relationship tends to exist between heart rate and oxygen uptake or workload for most adults. When the heart rate is less than 115, many external factors (e.g., talking, laughing, apprehension, etc.) can greatly influence heart rate. Once the heart rate reaches a level between 115 and

150, external factors no longer influence heart rate, and a linear relationship exists. As the heart rate rises above 150, the heart rate-oxygen uptake relationship becomes curvilinear.

The third assumption involves maximal heart rate. Maximal heart rate is the greatest heart rate that can be measured when an individual is exercising to the point of volitional fatigue (i.e., exhaustion) during a graded exercise test. Several equations have been developed to estimate the average maximal heart rate for humans:

- Maximal heart rate = 220 minus age (low estimate)
- Maximal heart rate = 210 minus [0.5 x age] (high estimate)
- Maximal heart rate = 226 minus age (estimate for older individuals)

Maximal heart rate can, however, vary greatly among different individuals of the same age. One standard deviation is + 12 bpm, which means that two-thirds of the population varies an average of plus or minus 12 heart beats from the average given by a prediction equation. If an individual's age-predicted maximal heart rate is higher than that person's true maximal heart rate, then his/her estimated  $\text{VO}_{2\text{max}}$  will be an overestimation of the correct or actual value.

The final assumption addresses the issue of mechanical efficiency. Because oxygen uptake at any given work rate can vary by approximately 15% between different individuals, individuals vary in the amount of oxygen they require to perform a certain exercise workload. Some individuals are more efficient at performing a given task than others. As a result, the average oxygen consumption associated with a given workload may vary significantly from one person to another. Thus,  $\text{VO}_{2\text{max}}$  predicted by submaximal exercise tests tends to be overestimated for those who are mechanically efficient and underestimated for those who are inefficient.

The point to remember is that submaximal exercise testing, though not as precise as maximal exercise testing, is not without advantages. For example, the results of such testing can provide a fairly accurate reflection of an individual's fitness status without the cost, risk, effort (on the part of the subject) and time involved in max testing. If an individual is given repeated

## 7000 PT CONSOLE

submaximal exercise tests and that person's heart rate response to a fixed workload is found to decrease over time, it is reasonably safe to conclude that the individual has made improvements in aerobic (cardiorespiratory) fitness, irrespective of the accuracy of the  $\text{VO}_{2\text{max}}$  prediction.

### Pretest Screening

Prior to any exercise test (maximal or submaximal), participants should complete a brief health/medical questionnaire, have their resting blood pressure and heart rate measured, and provide an informed consent form. The Physical Activity Readiness Questionnaire (PAR-Q) is an example of a valid health/medical questionnaire for screening individuals prior to submaximal exercise testing. Canadian health and fitness practitioners have extensively (and quite successfully) used the PAR-Q to determine whether individuals should be given an exercise test. A "yes" answer to any of the seven questions on the PAR-Q would disqualify a participant from taking part in an exercise test until appropriate medical clearance was obtained.

#### PHYSICAL ACTIVITY READINESS QUESTIONNAIRE (PAR-Q)

1. Has your doctor ever said you have a heart condition and recommended only medically supervised physical activity?
2. Do you have chest pain brought on by physical activity?
3. Have you developed chest pain within the past month?
4. Do you tend to lose consciousness or fall over as a result of dizziness?
5. Do you have a bone or joint problem that could be aggravated by the proposed physical activity?
6. Has a doctor ever recommended medication for your blood pressure or a heart condition?
7. Are you aware, through your own experience or a doctor's advice, of any other physical reason against your exercising without medical supervision?

### The StairMaster Submaximal Fit Test

The StairMaster branching protocol is a series of 3-minute stages of continuous exercise at increasing intensity. The first stage is a warm-up at approximately 4 METs. The intensity of the remaining stages is based on the heart rate response to the warm-up. The test is designed to raise the steady

state heart rate of the subject to 110 to 150 beats/min for two consecutive stages. It is important to remember that two consecutive heart rate measurements must be obtained in the 110 to 150 beats/min range to predict  $VO_{2max}$ . The test typically lasts from 9 to 15 minutes.

In the StairMaster protocol, each work rate is performed for 3 minutes, with heart rates recorded during the final 4 seconds of the second and third minutes of each stage. If the heart rates are within 5 beats/min, then the heart rate during the last minute is plotted against the work rate, and the program advances to the next 3-minute stage. The program continues for two to four stages until two steady state heart rates between 110 to 150 beats/min are obtained in two consecutive stages. The line generated from the plotted points is then extended to the age-predicted maximal heart rate. A corresponding maximal work rate and  $VO_{2max}$  can then be calculated.

At the end of the 3<sup>rd</sup> minute of each stage, if the heart rates at the end of the 2<sup>nd</sup> and 3<sup>rd</sup> minute are not within 5 beats/min of each other, then that work rate is maintained for an additional minute. At the end of the 4<sup>th</sup> minute, the heart rate is compared to the heart rate at the end of the 3<sup>rd</sup> minute. If the heart rates are within 5 beats/min, then the heart rate during the 4<sup>th</sup> minute is plotted against the work rate. If the heart rate at the end of the 3<sup>rd</sup> and 4<sup>th</sup> minute are not within 5 beats/min, then the work rate is maintained for one more additional minute. If the heart rate at the end of the 4<sup>th</sup> and 5<sup>th</sup> minutes are within 5 beats/min, then the heart rate at the end of the 5<sup>th</sup> minute is plotted against the work rate. If the heart rate at the end of the 4<sup>th</sup> and 5<sup>th</sup> minutes are not within 5 beats/min, then the test failed.

Once two consecutive heart rate measurements are obtained in the 110 to 150 beats/min range, then the test ends successfully and the results are displayed. Estimate maximum aerobic capacity is shown in ml/kg/min and METs. Next, the results are compared to normative values for others of the same age range and gender (see Table 2). Results are stored in the console until the next person starts an exercise program. Press [STATS SCAN] to review the results in addition to being displayed at the end of the test.

Figure 4: StairMaster® Fitness Protocol

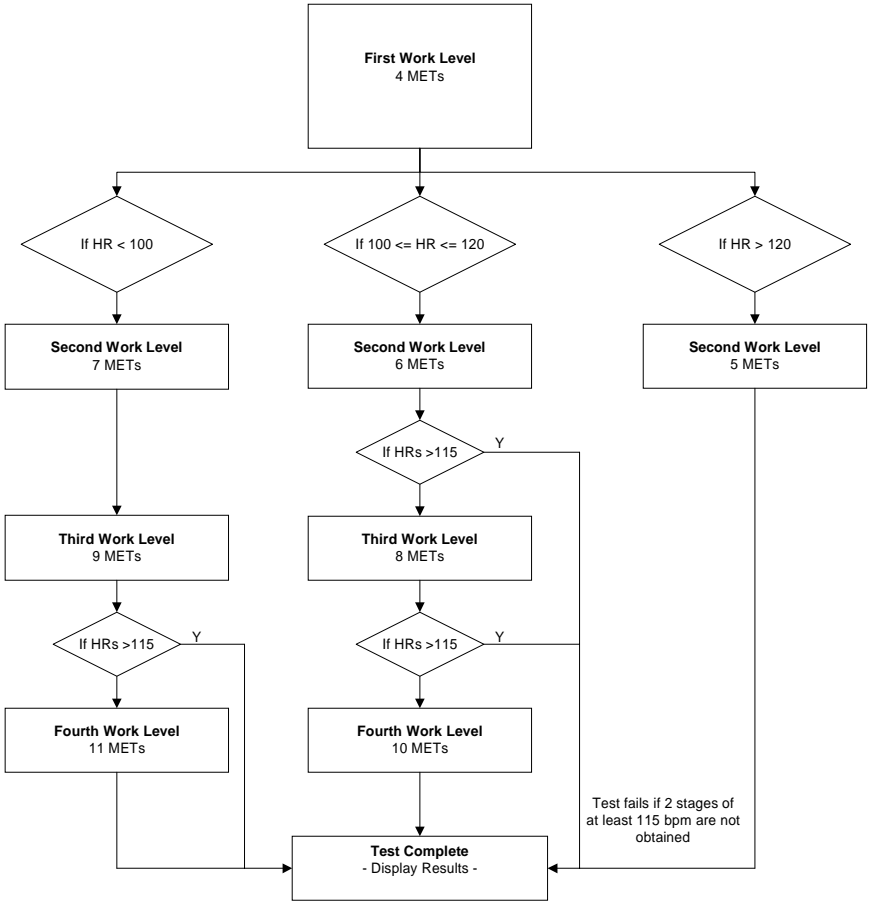

Table 2. Fitness Rating Norms ( $VO_{2max}$ )

<u>MEN</u>					
Age	High	Good	Average	Fair	Low
20 – 29	>51	51 – 47	47 – 43	42 – 40	<39
30 – 39	>50	50 – 45	45 – 41	41 – 37	<37
40 – 49	>48	48 – 42	42 – 38	38 – 35	<35
50 – 59	>45	45 – 39	38 – 35	35 – 32	<32
60+	>43	42 – 35	35 – 32	32 – 29	<29
<u>WOMEN</u>					
Age	High	Good	Average	Fair	Low
20 – 29	>44	44 – 38	38 – 35	35 – 32	<32
30 – 39	>41	41 – 37	37 – 34	34 – 31	<30
40 – 49	>40	39 – 34	34 – 31	31 – 28	<28
50 – 59	>35	35 – 31	31 – 28	28 – 26	<25
60+	>35	35 – 39	29 – 26	26 – 24	<24

### The Firefighter's Stair Climb Tests

The StairMaster StepMill is routinely used to assess the aerobic fitness levels of fire fighters in full protective gear carrying heavy equipment. The Candidate's Physical Ability Test (CPAT), approved by the International Association of Fire Fighters (IAFF) and reviewed by the U.S. Justice Department, requires each candidate to step on the StepMill at a predetermined stepping pace for a specific period of time. There are two fire fighter specific Stair Climb Test programs. The first test is the CPAT Stair Climb Test. The second test is a modified version of the CPAT test that is used by the New York City Fire Department (NYCFD).

- CPAT Stair Climb Test – (Fit Test #2) The first phase is a warm-up interval at intensity of 56 steps/min and lasts twenty-seconds. At the end of the first interval the time counter will reset to zero. The second phase continues through nine twenty-second





## 7000 PT CONSOLE

intervals at intensity of 68 steps/min. The CPAT Stair Climb Test has a total of ten intervals and lasts for three minutes, twenty seconds (including warm-up).

### Turning on the CPAT Stair Climb Test

1. Press [^], [9], [1], [ENTER], on the console keypad. Make sure to press in the middle of each key and be aware that the corresponding numbers will not show in the console display.
  2. The console will prompt you to "BEGIN FIT TEST." The test can be stopped at any time by pressing [STOP].
- NYCFD Stair Climb Test – (Fit Test #3) The first phase is a warm-up interval at intensity of 56 steps/min and lasts sixty-seconds, followed by a sixty-second rest period (no stepping). At the end of the rest period the time counter will reset to zero. The second phase is at intensity of 68 steps/min and lasts for five minutes, twelve seconds.

### Turning on the NYCFD Stair Climb Test

1. Press [^], [9], [2], [ENTER], on the console keypad. Make sure to press in the middle of each key and be aware that the corresponding numbers will not show in the console display.
2. The console will prompt you to "BEGIN FIT TEST." The test can be stopped at any time by pressing [STOP].

## CONSOLE CODES

There are three groups of console codes which are differentiated according to function. The first group of codes are customization codes and are used to set defaults such as units, language, heart rate input type, etc. The second group of codes are machine status codes and are used to track hours and other general usage patterns for maintenance purposes. The third group of codes are diagnostic codes and are used for troubleshooting. The following key actions are valid in each group of console codes:

- Pressing [LEVEL ^], [ 1<sup>st</sup> # ], [ENTER] displays what group of codes is being accessed.
- Pressing [SELECT] or [LEVEL ^] at that point allows you to view all possible selections. Once in this mode pressing [LEVEL v] backs up through the selections; pressing [ENTER] then selects that item. If another test level is available at this point, the [SELECT] / [ENTER] process is repeated.
- Pressing [^] [1<sup>st</sup> #, or 2<sup>nd</sup> #], [ENTER ] selects that item directly.
- Pressing [CLEAR] exits any of the special access modes.

### Custom Codes

[ ^ ][ 3 ][ 0 ]	change workout time limit between 5 to 99 minutes
[ ^ ][ 3 ][ 1 ]	change units (MPH or KMH)
[ ^ ][ 3 ][ 2 ]	choose type of heart rate input and priority (telemetry or contact)
[ ^ ][ 3 ][ 3 ]	- N/A -
[ ^ ][ 3 ][ 4 ]	choose console language
[ ^ ][ 3 ][ 5 ]	change contrast on console
[ ^ ][ 3 ][ 6 ]	- N/A -
[ ^ ][ 3 ][ 7 ]	- N/A -
[ ^ ][ 3 ][ 8 ]	- N/A -
[ ^ ][ 3 ][ 9 ]	reset to factory defaults

1. Change the workout time by pressing [LEVEL: ^], [ 3 , [ 0]. The console will display "MAX TIME." Press [ENTER]. The console will then display the current time limit. Use the keypad to enter the desired time, then press [ENTER]. For no time limit, press [0].

## 7000 PT CONSOLE

2. Change the units to either Metric or USA units by pressing [LEVEL: ^], [3], [1], [ENTER]. The console will display the current units - either "USA UNITS" or "METRIC UNITS." Use the [SELECT] key to change option, and then press [ENTER].
3. Choose the desired heart rate input preference by pressing [LEVEL: ^], [3], [2]. The console will then display "HR INPUTS." Press [ENTER]. The console will then display the current heart rate input selection. Press the [SELECT] key to scroll through the other options. Press [ENTER] after the desired option.
4. Change the language by pressing [LEVEL: ^], [3], [4]. The console will display "LANGUAGE." Press [ENTER]. The console will then display the current language. Press the [SELECT] key to scroll through the other options. Press [ENTER] to change the option.
5. Adjust the contrast on the LCD screen by pressing [LEVEL: ^], [3], [5]. The console will display "CONTRAST ADJ." Press [ENTER]. The console will then display the current contrast number. Press the [LEVEL: ^], and [LEVEL: v] keys to increase or decrease the contrast. The changed value will remain on exit.
6. Reset the console to factory defaults by pressing [LEVEL: ^], [3], [9]. The console will display "SET DEFAULTS ." Press [ENTER]. Then console will rest itself and then display "DONE."

### Quick Scan Programming

You can quickly access any of the custom menus by pressing [LEVEL: ^], [3], [ENTER]. The console will then display "CUSTOMIZE." Scroll through the following options:

[SELECT] "MAX TIME"	0
[SELECT] "CHANGE UNITS"	1
[SELECT] "HR INPUTS"	2
[SELECT] "LANGUAGE"	4
[SELECT] "CONTRAST ADJ"	5

[SELECT] "CONTRAST ADJ"	5
[SELECT] "MAX SPEED" - <b>N/A</b> -	6
[SELECT] "CLINICAL MODE" - <b>N/A</b> -	7
[SELECT] "SET DEFAULTS "	9

## Machine Status Codes

[ ^ ][ 4 ][ 0 ]	display machine run time in hours
[ ^ ][ 4 ][ 1 ]	display number of workouts
[ ^ ][ 4 ][ 2 ]	display distance traveled
[ ^ ][ 4 ][ 3 ]	display software rev
[ ^ ][ 4 ][ 4 ]	display machine type
[ ^ ][ 4 ][ 5 ]	<b>-N/A-</b>
[ ^ ][ 4 ][ 6 ]	display machine run time in hours since last cleared (used for maintenance)

1. Display the machine run time by pressing [LEVEL: ^], [4], [0]. The console will display "RUN HOURS XXXXX".
2. Display the number of workouts by pressing [LEVEL: ^], [4], [1]. The console will display "WORKOUTS XXXX."
3. Display the total distance covered up to date by pressing [LEVEL: ^], [4], [2]. The console will then display "DISTANCE XXXX."
4. Display the console software revision number by pressing [LEVEL: ^], [4], [3]. The console will display "CONS 92111-XXX."
5. Display the machine type by pressing [LEVEL: ^], [4], [4]. The console will display "STEPPER (or other machine type)."
6. Display the machine run time since last cleared by pressing [LEVEL: ^], [4], [6]. The console will display "MAINT HOURS XXXX."

# 7000 PT CONSOLE

## Quick Scan Programming

You can quickly access any of the custom menus by pressing [LEVEL: ^], [4], [ENTER]. The console will then display "MACHINE STATUS." Scroll through the following options:

[ SELECT ]	" RUN HOURS	XXXX"	0
[ SELECT ]	" WORKOUTS	XXXX"	1
[ SELECT ]	" DISTANCE	XXXX"	2
[ SELECT ]	" CONS	90211- XXX "	3
[ SELECT ]	" STEPMILL"		4
[ SELECT ]	<b>-N/A-</b>		
[ SELECT ]	" MAINT HOURS	xxxx"	6

## Resetting the Maintenance Hour Counter

For ease of maintenance records, the Stepmill® console has a maintenance timer that will clock the number of hours, workouts, and time between last servicing. After each maintenance period reset the counter.

[ ^ ] [ 7 ] [ 1 ] Reset Service

1. Reset the maintenance hour counter by pressing [LEVEL: ^], [7], [1]. The console will display "RESET SERVICE." Press [ENTER]. The console will display "DONE." Press [CLEAR] to return to the starting screen.

## Configuration Code

The Stepmill console supports other StairMaster® exercise systems. It is important to verify that the machine configuration code matches the type of machine you have. Speed control problems, along with other problems, can occur if the console is not set up correctly.

[ ^ ] [ 8 ] [ 0 ] Change Machine

1. Change the machine type by pressing [LEVEL: ^], [8], [0]. The console will display "CHANGE MACHINE." Press [ENTER]. The console will then display the current machine type. Use the [SELECT] key to toggle between options. Press [ENTER] for the desired option.

# MAINTENANCE INSTRUCTIONS

## HELPFUL HINTS

Read all maintenance instructions thoroughly before beginning work. In some cases, an assistant is required to perform the necessary tasks. The safety level given by the design of this equipment can only be maintained when the equipment is regularly examined for damage and wear. Inoperable components shall be replaced immediately or the equipment shall be put out of use until it is repaired. All references to the right or left side and to the front or back are made as if you were on the machine ready to exercise.

## TOOL LIST

The following tools are needed to perform service and maintenance:

- Standard screwdriver
- Combination wrenches (sizes 7/16 - 3/4")
- Combination pliers
- Shop goggles or other eye protection
- Allen wrench set (sizes 5/64 - 1/4")
- Socket set or nut driver set (sizes 1/4 - 3/4" in 1/16" increments)
- Phillips screwdriver
- Adjustable wrench
- External snap ring pliers
- Wire stripper/crimper tool
- Volt-ohm meter (multimeter)
- Locking pliers

## MAINTENANCE RECORDS

For ease of maintenance the 4400/4600 PT/CL console will keep track of hours, number of workouts, time between last servicing, etc. You can quickly access any of the custom menus by pressing [LEVEL: ^], [4], [ENTER]. The console will then display "MACHINE STATUS". Scroll through the following options:

[ SELECT ]	" RUN HOURS	XXXX"*	0
[ SELECT ]	" WORKOUTS	XXXX"	1
[ SELECT ]	" DISTANCE	XXXX"	2
[ SELECT ]	" CONS	90211- XXX "	3
[ SELECT ]	" STEPMILL"		4
[ SELECT ]	<b>-N/A-</b>		
[ SELECT ]	" MAINT HOURS	xxxx"	6

\*The machine may show a few hours of use due to testing at the manufacturing facility.

# MAINTENANCE INSTRUCTIONS

## INITIAL SERVICE

Upon receiving your machine, use a soft, clean towel to wipe off the dust which may have accumulated during shipping. Your new machine will require minor assembly. Refer to the “Installation Instructions” section of this Manual for details.

## PREVENTIVE MAINTENANCE

The procedures for performing the recommended preventive maintenance are summarized in Table 3. The schedule is based on normal usage in a commercial health club environment; adjust the schedule to meet actual machine usage. Refer to the “Parts Removal and Replacement” section of this Manual for all disassembly and assembly instructions.



### WARNING

TO AVOID INJURY DUE TO SLIPPERY PEDAL SURFACES, DO NOT USE PETROLEUM-BASED CLEANERS OR ARMORALL-TYPE PROTECTANTS ANYWHERE ON THIS MACHINE OR THE FLOOR MATS.

## Cleaning and Inspecting

1. DO NOT USE GLASS CLEANERS OR ANY OTHER HOUSEHOLD CLEANER ON THE CONSOLE. Clean the console daily with a water-dampened cloth and wipe dry after cleaning.
2. Clean the exterior of your Stepmill® 7000 PT exercise system daily with soap and water.
3. Thoroughly clean the entire machine at least once a week.
4. Inspect the painted surfaces of the exposed frame for any rust, bubbling or chips during the weekly cleaning. The salt in perspiration can damage the unpainted surfaces. Repair the damaged area with a rust-inhibitor paint. Contact our Customer Service Department at 800-331-3578 to order a touch-up paint kit.

## MAINTENANCE INSTRUCTIONS

5. Clean the step hinges carefully. Perspiration tends to accumulate in the hinges, and this can lead to eventual corrosion.
6. Inspect the Poly-V belt for excessive wear during the weekly cleaning. Adjust the belt tension if necessary.

### Lubrication

The StairMaster® Stepmill® 7000 PT exercise system has six components that require periodic lubrication: the drive chain, the two step chains, the two bearing plates and the step hinges. These parts are shown in the figure below. You will need to remove the side covers to lubricate the chains and the bearing plates.

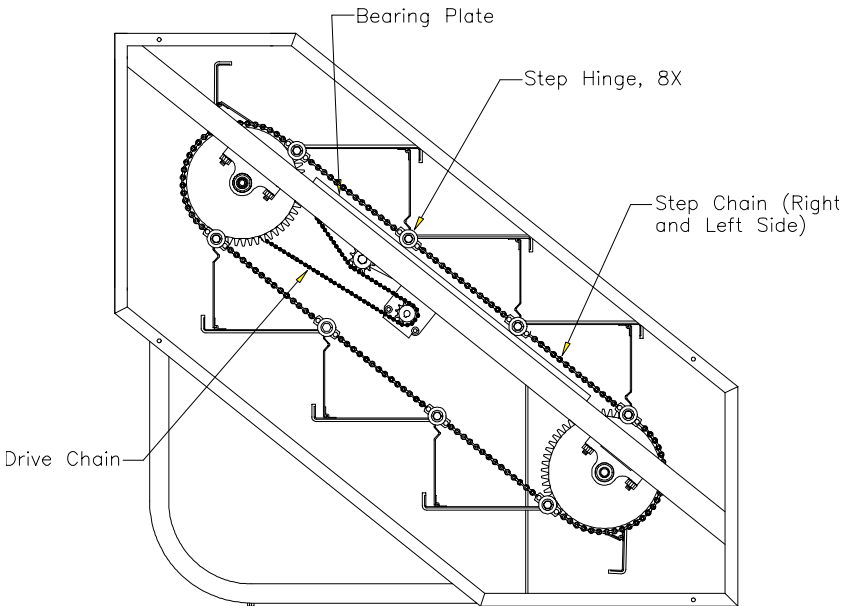

1. Place a protective mat on the floor while you are lubricating your machine. A rubber floor mat is available from StairMaster Health & Fitness Products, Inc.



## MAINTENANCE INSTRUCTIONS

2. Lubricate the chains monthly with 30W motor oil. Drip the oil onto the chain plates and rollers. Let the oil soak in for a few minutes and then remove any excess oil with a dry rag.
3. Remove the chains every three months to thoroughly clean and lubricate them. Use a mild degreaser and a stiff brush to remove dirt and corrosion from the chain. Read the instructions on the degreaser container before using.
4. Clean each bearing plate and lubricate it with multipurpose grease every three months. The plate is lubricated to reduce friction when the step shaft bearings roll over the plate.
5. Once per month, use 30W motor oil or brush light bearing grease into the step hinges to lubricate the hinges and to prevent corrosion. Wipe off all excess lubricant.



### **WARNING**

TO REDUCE THE POSSIBILITY OF SLIPPING, BE SURE THE STEP AREA IS FREE OF GREASE OR OIL. WIPE ANY EXCESS OIL OFF THE MACHINE SURFACES.

# MAINTENANCE INSTRUCTIONS

**Table 3. Recommended Preventive Maintenance Schedule**

PART	RECOMENDED ACTION	FREQUENCY	CLEANER	LUBRICANT
Exterior Surfaces	Clean	Daily	Soap & water	N/A
Console	Wipe Clean	Daily	Water	N/A
Poly-V Belt	Inspect and adjust if necessary	Weekly or after 70 hours of use	N/A	N/A
Step Chain Assembly	Lubricate	Monthly or after 300 hours of use	N/A	30W motor oil
	Clean and lubricate	Quarterly or after 900 hours of use	Mild degreaser	30W motor oil
Drive Chain	Lubricate	Weekly or after 70 hours of use	N/A	30W motor oil
	Clean and lubricate	Quarterly or after 900 hours of use	Mild degreaser	30W motor oil
Step Hinges	Lubricate	Monthly or after 300 hours of use	N/A	30W motor oil
Bearing Plate	Clean and lubricate	Quarterly or after 900 hours of use	Clean, dry rag	Multipurpose grease

**\*Note:** Use of lubricants other than those so specified will result in diminished performance and a shorter life span for that part.



# TROUBLESHOOTING

## GENERAL TROUBLESHOOTING GUIDELINES

This section outlines several tests to systematically identify and isolate the cause of problems in the electrical system and the drive train. This troubleshooting section is organized into four basic problem sections: Electrical System, Console Diagnostics, Speed Control, and the Drive Train. The first step is to identify the problem. Once you have identified the problem, perform all the tests in exactly the same order as written. Refer to the “Parts Removal and Replacement” section of this Manual for all disassembly and assembly instructions. To order a replacement part, or to get help with the troubleshooting process, contact our Customer Service Department at 800-331-3578. International customers should contact their local distributor or call 425-823-1825.

## TROUBLESHOOTING THE ELECTRICAL SYSTEM

The electrical system consists of: the power supply, main cable, relay board, load resistor, and the console. In order to identify the component that is causing the problem, you must systematically test the system. You will need a volt-ohm meter (multimeter) to conduct portions of the following procedures. The console and power supply are not serviceable by the owner. If either of these parts are inoperable, they must be replaced. Opening the console or the power supply will void the warranty.

### The Console Fails to Power Up

- A. Perform a visual check of the machine. Check the following things first:
  - 1. Is the power supply plugged in?
  - 2. Is the indicator light lit on the power supply? If it is, proceed to step #3. If the light is not on, go to step B.
  - 3. Replace or exchange your console with a console you know is good and retest the machine.
- B. Verify AC power.
  - 1. Disconnect the AC power cord from the AC wall outlet.

## TROUBLESHOOTING THE ELECTRICAL SYSTEM

2. Verify that the AC wall outlet is supplying the correct power in one of two ways: a) Use a voltmeter to verify that the AC line voltage is between 108 and 130 VAC (or between 208 and 240 VAC, if applicable) at the AC wall outlet; or b) Plug in an alternate AC-powered device (a lamp, for example). If the AC wall outlet is supplying the correct power, proceed to step #3. If the voltage is outside the range or if the device does not work when plugged into the AC wall outlet, consult an electrician for further assistance and then retest the AC wall outlet.
  3. Plug the AC power cord into the wall outlet and proceed to the next section.
- C. Verify DC power.
1. Make sure that the AC power cord is plugged in and that the AC wall outlet is delivering the proper voltage.
  2. The indicator light should be lit. If it is, proceed to step #3. If the indicator light is still not lit, replace the power supply and test the new power supply.
  3. Disconnect the cable from the DC power connector located on the bottom cover. Use a DC voltmeter to verify 12-19 VDC at the end of the DC cable. Pin #1 is negative and pin #2 is positive. Proceed to step #4 if the VDC is within the range. Replace the power supply if the VDC is outside the range and test the new power supply.
  4. Remove the right side cover. Reconnect the DC power cable to the machine. Locate the relay/resistor circuit board located just inside the frame, midway between the top and bottom steps (refer to Wiring Diagram 1). There are three red indicator lights along the bottom edge of the relay assembly circuit board. They are labeled, from top to bottom: Field, Power, and Relay. Ensure the black and white wire power connector (labeled J2 on the relay resistor circuit board) is securely connected to the relay resistor circuit board.
    - a. The Power light should be lit. If it is, go to step #5. If it is not, disconnect the power connector from the J2 position on the relay

## TROUBLESHOOTING THE ELECTRICAL SYSTEM

- assembly circuit board (refer to Wiring Diagram 2). Use a DC voltmeter to measure the VDC at the power connector. Pin #1 is negative and Pin#10 is positive. The reading should be between 12 and 19 VDC. If you are not getting power to the connector, replace the power connector assembly and retest.
- b. If you are getting the correct voltage at the power connector, reconnect it to the J2 position on the relay assembly circuit board. Disconnect the main cable connector at the J1 position of the relay assembly circuit board. Check the VDC reading at the silver tabs on the relay assembly circuit board. Tab #4 (labelled +/WHT) is positive and tab #5 (labelled GND/BLK) is negative (refer to Wiring Diagram 2). You should get a reading between 12 and 19 VDC. If your reading is not within the range, replace the relay assembly circuit board and retest.
  - c. If you are getting the correct voltage at tabs #4 and #5, check the VDC reading at the connector labeled position J1 on the relay assembly circuit board. Pin #4 is positive and pin #5 is negative. You should get a reading between 12 and 19 VDC. If your reading is not within the range, replace the relay assembly circuit board and retest.
  - d. If all of the above power tests produce VDC readings that are within range and the Power indicator light is still not lit, the Power indicator light is probably inoperable. Replace the relay assembly circuit board, reconnect all wires, and retest.
5. Remove the console and disconnect the console cable. Use a DC voltmeter to measure the VDC at pin #1 (negative) and pin #10 (positive) of the console cable connector. You should get a reading between 12 and 19 VDC. If the reading is not within the range, replace the cable assembly and retest.

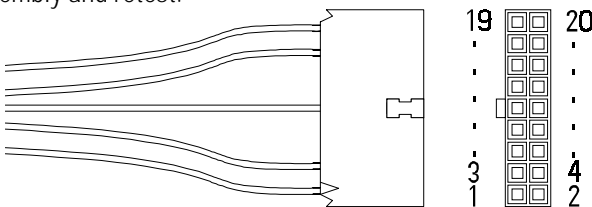

## CONSOLE DIAGNOSTIC TESTS

The following tests are performed while the console is in the "SELECT WORKOUT" mode. If the console fails any test, the console should be replaced or exchanged. To return to the "SELECT WORKOUT" mode, press either [CLEAR] or [START/STOP] while in the DIAGNOSTIC mode. Please note that there may be additional verbiage on the display other than is listed in this manual. The Stepmill® 7000 PT console is used on other StairMaster® equipment.

### Diagnostic Codes

[^][6][0] Test display  
[^][6][1] Test keyboard  
[^][6][2] Test serial port  
[^][6][3] Test alternator  
[^][6][4] -N/A-  
[^][6][5] -N/A-  
[^][6][6] Test Tach  
[^][6][7] - [6][9] -N/A-

### The Display Test

During the display test, the console screen alternates between all LCD segments turned on, and sample program profile screen at a 2-second rate.

1. Press [LEVEL: ^], [6], [0], [ENTER]. The console will display "DISPLAY TEST".
2. All LCD segments will turn on for 2 seconds and then a sample program profile will be displayed for 2 seconds. Press [CLEAR] to end the test.

### The Keypad Test

Perform this test if you are having trouble entering data into the console. During the test, pressing any key displays that key name on the message line. Press [CLEAR] to exit.

1. Press [LEVEL: ^], [6], [1], [ENTER] to start the test.



## CONSOLE DIAGNOSTIC TESTS

2. Firmly press each button except [CLEAR]. The name of the key will be shown in the display window. Press [CLEAR] to end the test.

### The Serial Port Test

This test verifies that the RS 232 port used for linking to commercial entertainment systems is working. You must have the loop-back cable assembly, pn 040051-001 to perform this test.

1. Insert the loop-back cable assembly into the RS 232 port on the back of the console.
2. Press [ LEVEL: ^ ], [ 6 ], [ 2 ], [ENTER], to start the test.
3. The console will run a diagnostic test and then display either "PASS" or "FAIL". Replace the console if it fails this test.

### The Alternator Test

Use this test to verify the alternator field routines of the console. You will need to briefly exercise on the machine for this test.

1. Press [ LEVEL: ^ ], [ 6 ], [ 3 ], [ENTER], to start the test.
2. For "Field on" press [ LEVEL: ^]. Step on the machine for approximately 10 to 15 seconds. If full resistance is achieved during this time, your console has correct current flow. If no resistance is achieved, either the console or the alternator is bad. See the electrical troubleshooting portion of this manual to isolate and test the alternator. Replace the console if the alternator is good.
3. For "Field off" press [ LEVEL: V]. Step on the machine for approximately 10 to 15 seconds. You should not get resistance with the field turned off. Press [CLEAR] to end the test.

## The Tach Test

If you do not have resistance, perform the tach test. The tach test will tell you the tach signal, in revolutions per minute (RPMs), picked up by the console.

1. Press [ LEVEL: ^ ], [ 6 ], [ 6 ], [ENTER]. The console will display "TAR TACH ACT". The target tach speed of 2000 RPMs will be shown in the upper left corner of the display window. The actual tach picked up by the console will be shown in the upper right corner of the display window.
2. Start stepping on the steps. The number in the right hand corner of the console should increase to 2000 RPMs (+/- 200). If the tach signal picked up by the console is less than 1900 RPMs then there is a problem in the AC tach circuit - either with the console software, alternator (check the AC tach wire, the field wire, the diode, and the terminal posts), or the main cable.

## Error Reporting

The console will display various error messages in the display window. The total amount of errors will be displayed in the upper right numeric window. Note that only the highest priority reported error will be displayed. Errors are handled in two ways. One as a non-fatal "WARNING" which will display the text message but continue system operation until the user presses the [CLEAR] key. The second way is as a fatal "ERROR" which will stop the exercise and return the system to an idle intensity state. The console will display the error text and not let the user restart the programs unless power has been turned off and then back on.

The following microprocessor errors require a console replacement; ALU ERROR, TIMER ERROR, and STATIC RAM ERROR.

Resetting the power may clear the following microprocessor errors; EEPROM ERROR, and PROGRAM ERROR. If resetting the power doesn't work, the console may need to be replaced.



# CONSOLE DIAGNOSTIC TESTS

## The Telemetry (Polar®) Heart Rate Test

The telemetry heart rate system is made up of the console, the heart rate receiver, and the chest strap (available separately). You can test each component by performing the following steps:

1. You will need to put a chest strap on in order to test the telemetry heart rate. Before you put on the chest strap, wet the two contact patches. Secure the chest strap as high under your pectoral muscles (chest) as is comfortable. The chest strap should fit snugly, comfortably, and allow normal breathing.
2. A flashing ♥ should be displayed on the console. Your heart rate, in beats per minute, will show next to the heart icon. If the heart icon does not show, or if your heart rate is not displayed on the console then you have a problem with either the console, chest strap, or heart rate receiver.
3. Verify that the console software has been set up to receive telemetry (see the heart rate monitoring section of this manual). Note that holding the contact heart rate sensors (if enabled) can inhibit the telemetry heart rate input from working.
4. Test your chest strap with a machine that you know is working, or with a heart rate watch that you know is working.
5. If possible, replace or exchange your console with a machine that you know is working and retest the machine.
6. Excess false heart rate detection: the telemetry receiver located in the console is susceptible to mechanical vibration as well as external electrical interference. Hitting the console or the frame may momentarily cause errant heart beat detection - this is normal. If excessive false heart beats appear only during workouts, check that the console cable is not curled up behind the console. Pull as much of the cable down and away from the console as possible. False heart beats while the machine is idle are most likely due to external interference. Try plugging the machine into a different outlet, or moving it to a new location.

# SPEED CONTROL PROBLEMS

If you have problems with erratic speed control while operating the machine, the cause may be either electrical or mechanical in nature. You will have to remove the side covers to conduct most of these tests.

A. Perform a visual check of the machine. Check the following things first:

1. Inspect the Poly- V belt for proper tension and excessive wear. A loose belt will cause excessive noise and wear. The machine will run sluggishly if the belt is too tight.
2. Replace a worn or frayed Poly-V belt. Adjust the belt so that there is 1/10" (0.3 cm) deflection at a point midway between the alternator and transmission pulleys with fingertip pressure (See Drawing Below).

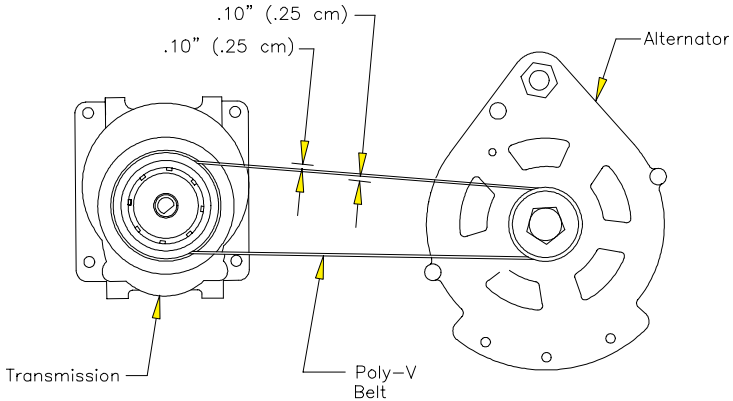

3. Check for proper wire connections on the alternator, relay assembly circuit board, and load resistor (See Drawing Below).

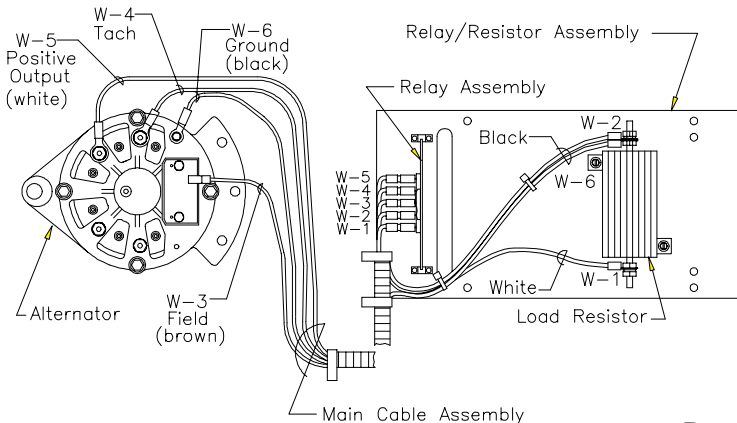

## SPEED CONTROL PROBLEMS

4. Replace or exchange the console with another console you know is good and retest the machine.
- B. Check the relay assembly circuit board while the console displays "SELECT WORKOUT." You will need an assistant to complete the test of the relay assembly circuit board.
1. Remove the right side cover. Locate the relay assembly circuit board located just inside the frame, midway between the top and bottom steps (refer to Wiring Diagram). There are three red indicator lights along the bottom edge of the circuit board. They are labeled, from top to bottom: Field, Power, and Relay. Ensure the black and white wire power connector (labeled J2 on the relay assembly circuit board) is securely connected to the relay assembly circuit board (refer to Figure Below).

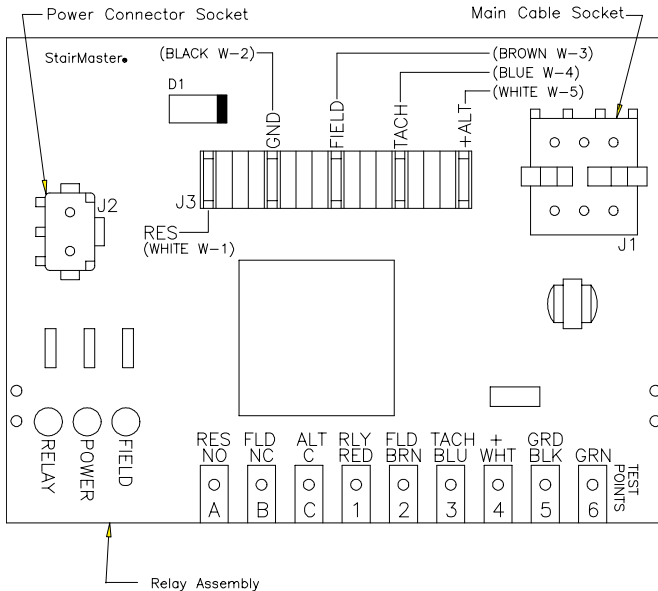

2. If the Power light is lit, go to step #3. If it is not, perform the tests as described in step 4b - c of the "Console Fails to Power Up" section.
3. The relay indicator light should be lit. If it is lit, proceed to step #5. If it is not, use a jumper wire on the relay assembly circuit board. Jump the silver tabs #1 (labeled RLY/RED) and #5 (labeled GRD/BLK) (refer

## SPEED CONTROL PROBLEMS

to Figure on page. 34). The relay indicator should light up. If it does, go to step #4. If the relay indicator does not light up, the relay assembly circuit board must be replaced. Replace the relay assembly circuit board and retest the machine.

4. You must check the cable assembly for continuity if the relay indicator lit up when you jumped tabs #1 and #5.
  - a. Unplug the main cable from the position labeled J1 on the relay assembly circuit board. Disconnect the console cable from the back of the console. Set your multimeter to the continuity check mode; on most meters, this will be the resistance or ohms setting.
  - b. Place one lead of the multimeter on pin #1 at the console connector end of the console cable (refer to Wiring Diagram). Place the other lead on pin #1 at the end of the main cable you disconnected from the relay assembly circuit board. You will get a reading of near zero ohms if there is continuity in the cable assembly.
  - c. Check continuity in both ends of the main cable assembly at pin #5.
  - d. If there is no continuity in the cable assembly at either pin, replace the cable assembly and retest. If there is continuity in the cable assembly at both pins and the relay resistor indicator is not lit, the console is inoperable and must be replaced.
5. Have your assistant step on the staircase (leave the console in the ATTRACT mode) while you check the field indicator light. It should be flickering. If it is and you still have a speed control problem, go to step #6.

If it is not flickering, ensure the following: the console cable is connected to the console; the console/main cable connection is secure; the connector at position J1 on the relay assembly circuit board is securely connected; that there is continuity in the cable assembly. To check for continuity:



## SPEED CONTROL PROBLEMS

- a. Unplug the connector at position J1 on the relay assembly circuit board. Disconnect the console cable from the back of the console. Set your multimeter to the continuity check mode; on most meters this will be the resistance or ohms setting.
  - b. Place one lead of the multimeter on pin #2 at the console connector end of the console cable. Place the other lead on pin #2 at the end of the main cable you disconnected from the relay assembly circuit board. You will get a reading of near zero ohms if there is continuity in the cable assembly.
  - c. If there is no continuity in the cable assembly, replace it and retest. If there is continuity in the cable assembly and the field indicator light is still not flickering, contact the Customer Service Department at 800-331-3578 for further assistance.
6. If the field indicator was flickering while your assistant was on the machine and you still have a problem with speed control, you need to test the alternator.
- a. Disconnect the white wire (labeled positive output on the alternator) and the brown wire (labeled "Field" on the alternator). Use a jumper wire to jump the Field and positive output terminals of the alternator.
  - b. Have your assistant step onto the staircase. Does the staircase slow down? If it does not, you need to replace the alternator. If the staircase does slow down, contact the Customer Service Department for further assistance.
  - c. Replace or exchange the alternator with another alternator you know is good and retest the machine.
  - d. Test the load resistor as outlined in the "Load Resistor Test" section of this Manual. If the speed control problem still exists, contact the Customer Service Department at (800) 331-3578 for further assistance.

## LOAD RESISTOR TEST

The alternators are heavy-duty models designed to withstand the rigors of commercial use. One possible reason for repeated failure is an inoperable load resistor. To test the load resistor:

1. Unplug the AC power cord from the AC wall outlet.
2. Locate the load resistor mounted to the relay board assembly just under the staircase.
3. Disconnect one black wire from the resistor (See Drawing Below).
4. Set your multimeter for R x 1 or the lowest available resistance range. If you have an analog multimeter, touch the two leads together and adjust the meter for a zero reading.
5. Place one lead on Tab A and one lead on Tab 5 of the relay assembly circuit board (See Drawing Below). You should get a reading of approximately 1.0 ohm or less.
6. Replace the load resistor if the reading is out of range and retest the new load resistor.
7. Reconnect the AC power cord and reinstall the right side cover.
8. If the problem still exists, contact the Customer Service Department at (800) 331-3578 for further assistance.

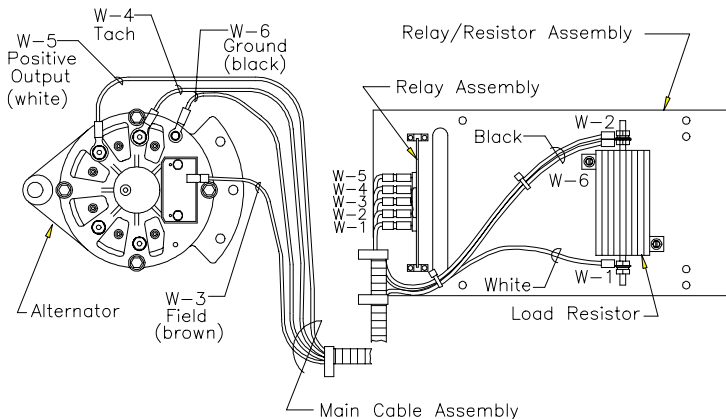

## TROUBLESHOOTING THE DRIVE TRAIN

If you hear a grinding or clicking noise, or experience excessive vibration during exercise, or if the steps are not functioning properly, you probably have a problem in the drive train. Attempt to isolate the problem area by performing the following tests in precisely the order listed below. Refer to the "Parts Removal and Replacement" Section of this Manual for all disassembly and assembly instructions.

1. Unplug the power supply from the AC wall outlet and remove the side covers.



### WARNING

TO REDUCE THE RISK OF INJURY, DO NOT OPERATE THE MACHINE WHILE THE SIDE COVERS ARE REMOVED. DO NOT ROTATE THE STAIRS WHILE ANYONE'S HANDS ARE INSIDE THE MACHINE.

2. Check the condition and the tension level of the Poly-V belt. Replace the belt if it is excessively worn.
  - a. Adjust the tension level so that you can deflect either side of the belt 1/10" (0.3 cm) at the center between the alternator and the transmission pulleys (See Drawing Below). Noise can be generated by a belt that is too tight or too loose.

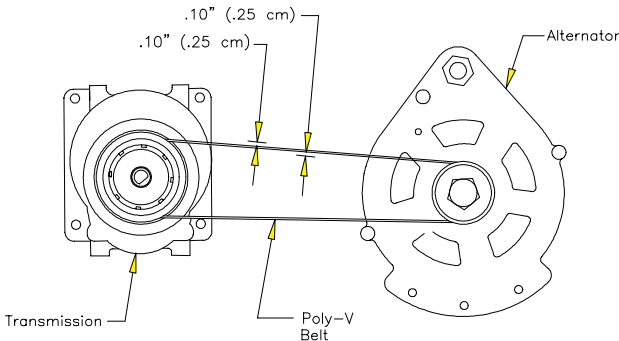

- b. If the noise is still present, remove the Poly-V belt and rotate the staircase without standing on it. With the Poly-V belt removed, the staircase will rotate very quickly.
- c. If the noise no longer exists, replace the alternator.

## TROUBLESHOOTING THE DRIVE TRAIN

3. Check the condition of the alternator.
  - a. Unplug the alternator from the relay board and remove the Poly-V belt.
  - b. Spin the alternator pulley with your fingers. It should spin freely and remain spinning for at least one and one-half revolutions. If it does not spin as it should, the bearings may be bad and the alternator should be replaced.
  - c. If the pulley does spin freely, check the alternator for noise, roughness, or the presence of black powder inside the alternator or near the outside of the case. If any of these conditions exist, the brushes may be bad and the alternator should be replaced.
  - d. Reconnect the Poly-V belt and adjust the belt tension.
4. Check the drive chain mechanism. Rotate the stairs and look for chain links that do not flex as the chain travels over the sprockets. If the links are frozen or sticking, replace the chain.
5. Check the transmission.
  - a. Rotate the steps by hand and listen for the noise.
  - b. If you hear the noise, remove the drive chain and the Poly-V belt. Rotate the steps by hand again and listen for the noise. If the noise has gone away, replace the transmission.
6. Check the step chain assemblies.
  - a. Have your assistant slowly exercise on the machine. Observe the staircase. If the staircase moves to the left or right during exercise, ensure the set screws in the bearing adjusters are tight.
  - b. Rotate the stairs and look for chain links that do not flex as the chain travels over the sprockets. If the links are frozen or sticking, replace the chain.



## TROUBLESHOOTING THE DRIVE TRAIN

7. Check the condition of the upper and lower sprocket assemblies. Replace the sprocket assembly if it is worn excessively, has broken teeth, or if it is bent.
8. Check the alignment of the upper and the lower sprocket assemblies. The outside face of the upper and lower sprockets should be 1-11/16" (4.3 cm) from the outside edge of the left frame rail. Loosen the nuts on the pillow block bearing collars and tighten or loosen the bearing adjuster set screws until the distance to both sprockets is correct. Tighten the pillow block bearing nuts and verify the distance.
9. Check the step assembly.

- a. Rotate the steps and check the hinges, step shafts, washers, and bearings (See Figure to Right) for wear, corrosion and lack of lubrication. Replace any worn parts.
- b. Ensure the nuts at each step shaft end are tight.

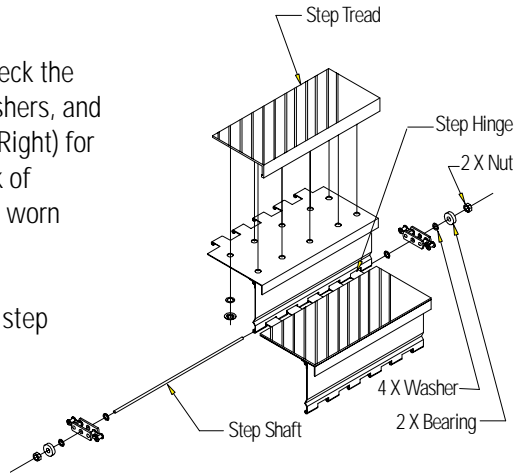

10. Reinstall all parts. If the problem still exists, contact the Customer Service Department at 800-331-3578 for further assistance.

# PARTS REMOVAL AND REPLACEMENT

## COVERS



### WARNING

TO REDUCE THE RISK OF INJURY, DO NOT OPERATE THE MACHINE WHILE THE SIDE COVERS ARE REMOVED. DO NOT ROTATE THE STAIRS WHILE ANYONE'S HANDS ARE INSIDE THE MACHINE.

There are five covers on the machine: two side covers, a back cover, a bottom cover, and a top cover. The side covers overlap the top cover. The side covers must be removed before the top cover and/or the bottom cover can be removed.

All covers are held in place with reusable plastic fasteners (refer to Figure 5 for their location). To remove the fasteners, slide either end of the fastener removal tool under the edge of the pin head (refer to Figure 6). The pin should not be removed. Pull the cover away from the frame. Do NOT use the fastener removal tool or any other sharp tool to pry out the fastener base because you may damage the covers - use the fastener removal tool to remove the pin.

To reinstall the fastener, insert the base of the fastener through the cover and into the frame. When the base is in place, push the pin in all the way to secure the fastener.

### Side Covers

1. Remove the 14 fasteners on each side cover.
2. Pull the cover away from the frame.

### Top Cover

1. Remove both side covers.
2. Lift the top cover away from the frame.
3. Set the top cover in place. Secure the side covers to complete reinstallation.



## **PARTS REMOVAL AND REPLACEMENT**

### **Back Cover**

1. Remove the 8 fasteners and lift the back cover away from the frame.
2. Align the holes in the frame and the back cover. Secure the back cover with the 8 fasteners.

### **Bottom Cover**

1. Remove both side covers to gain access to the bottom cover fasteners.
2. Disconnect the DC power cable.
3. Remove the six fasteners and remove the bottom cover from the frame.
4. Reinstall the bottom cover, then the two side covers. Remember to connect the DC power cable.

### **CONSOLE**

1. Locate the mounting knobs on the back of the console (See cutaway view Below).
2. Loosen and remove the four mounting knobs and lock washers.
3. Lift up the console and unplug the console cable from the back of the console.
4. Remove the console from the frame.
5. Reinstall the console by reversing the steps.

# PARTS REMOVAL AND REPLACEMENT

## POLY-V BELT



THE POLY-V BELT MUST BE ADJUSTED SO THAT THE CENTER OF EITHER SIDE CAN BE DEFLECTED 1/10" (0.3 CM) FROM ITS CENTER LINE WITH FINGER-TIP PRESSURE. A TIGHT BELT WILL CAUSE SLOW AND SLUGGISH OPERATION; A LOOSE BELT WILL CAUSE EXCESSIVE NOISE AND BELT WEAR.

1. Remove the left side cover.
2. Loosen the adjustment bolt that mounts the alternator to the slotted alternator brace then loosen the pivot nut.
3. Pivot the alternator forward to loosen the belt. Remove the Poly-V belt.
4. When reinstalling the Poly-V belt, pivot the alternator forward or back as necessary to allow 1/10" (0.3 cm) of play on either side of the belt (See Figure Below).

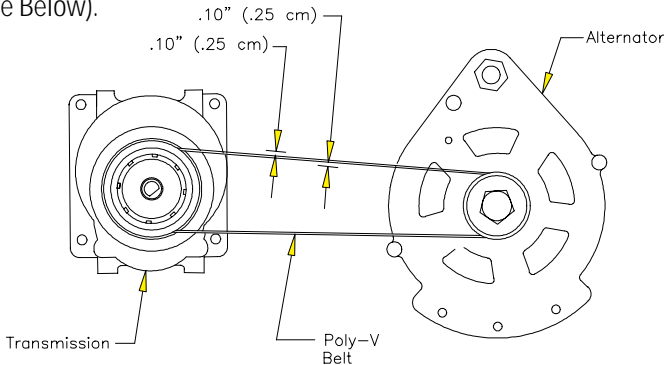

5. Tighten the adjustment bolt and verify the Poly-V belt tension.

## DRIVE CHAIN

1. Remove the left side cover.
2. Remove the retaining clip and retaining plate from the drive chain master link. Do not remove the master link from the drive chain yet.

## PARTS REMOVAL AND REPLACEMENT

3. Push up on the idler arm with one hand to relieve the tension on the drive chain (See Drawing Below). Remove the master link from one end of the drive chain and remove the drive chain from the sprockets.

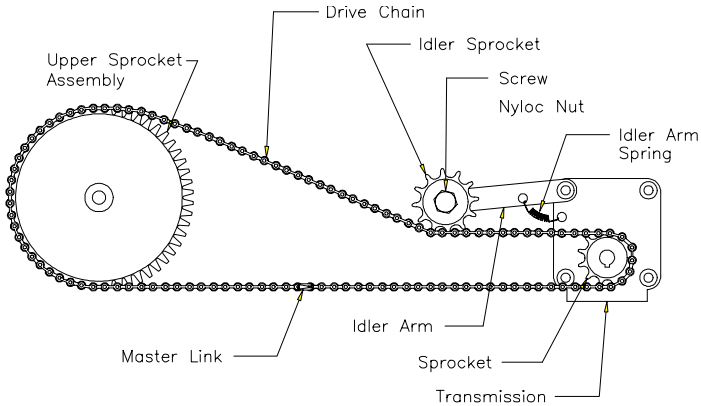

4. Install the new drive chain by reversing the steps.

## STEP ASSEMBLY

1. Remove the right and the left side covers.
2. Rotate the stairs until the step you want to remove is positioned in the middle of the staircase.
3. Loosen and remove the nut from one end of the step shaft on both the upper and the lower hinges of that step (See Figure to Right).

4. Remove the bearing and the washer from each step shaft.
5. Grasp the opposite step retaining nut with pliers or locking pliers. Pull the step shaft out of the upper and lower step hinges.

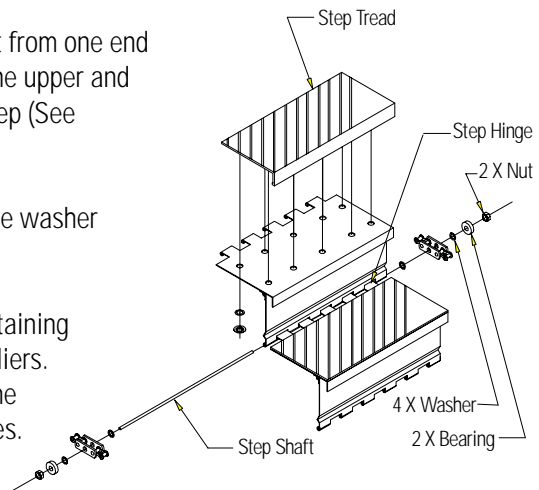

# PARTS REMOVAL AND REPLACEMENT

Be careful to not lose the washer located between the step and the modified link.

**Note:** Each step assembly weighs approximately 15 lbs. Be aware of finger placement when removing the step assembly.

6. Reinstall the step by reversing the procedures.

## STEP CHAIN ASSEMBLY

1. Remove the right and the left side covers.
2. Rotate the stairs to position the step chain master link on the lower span of the chain. It may be necessary to reduce the chain tension to remove the master link. Perform the following steps to reduce the chain tension:
  - Count and write down the number of exposed threads on the top bearing adjuster set screw for a reference when you reassemble the parts (See Figure Below).

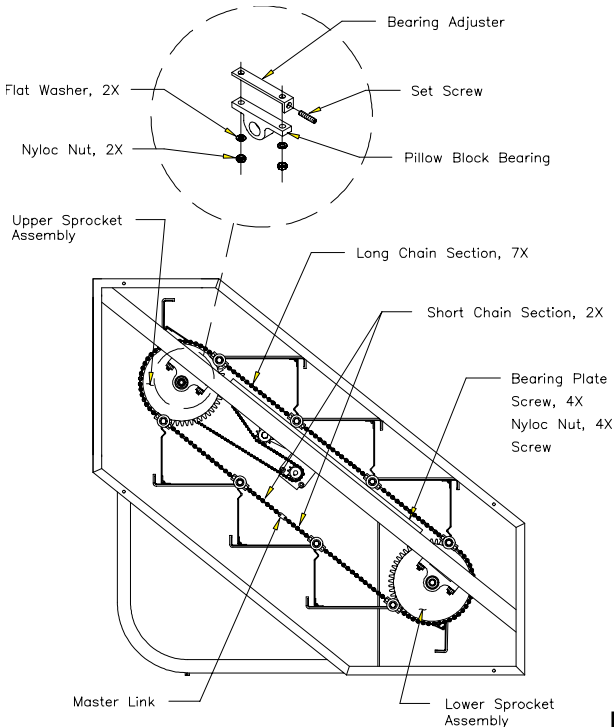



## PARTS REMOVAL AND REPLACEMENT

- Loosen the nuts on the pillow block bearing housing.
  - Loosen the bearing adjustment set screw until the chain tension level is relieved to a point where the master link may be disconnected.
3. Remove the master link.
  4. Using the old master link, connect the new chain assembly to the lower half of the old chain assembly.
  5. Remove the nut from the step shaft above the master link. It may be necessary to place another 5/16"-18 nut on the opposite end of the step shaft to gain leverage and remove the nut.
  6. Remove the bearing, the outer step shaft washer and the modified link of the old step chain assembly from the step shaft.
  7. Place the modified link of the new step chain assembly on the step shaft. Reinstall the outer step shaft washer, bearing and nut.
  8. Rotate the steps until the next step shaft is in approximately the same place as the previous step shaft.
  9. Repeat steps 6-8 until the new chain assembly is installed on the remaining step shafts.
  10. Remove the master link connecting the old chain with the new chain.
  11. Connect the new chain assembly together with the master link. Tighten the bearing adjustment set screw until the same number of threads as in step 2 are exposed. Tighten the nuts on the pillow block bearing housing.
  12. You should consider replacing the opposite step chain so that both chains will wear equally.
  13. Reassemble the machine in reverse order.

# PARTS REMOVAL AND REPLACEMENT

## UPPER (AND LOWER) SPROCKET ASSEMBLY

1. Remove the right and left side covers.
2. Remove all of the steps.
3. Remove the drive chain if you are removing the upper sprocket assembly.
4. Count and write down the number of exposed threads on the bearing adjuster set screws on both sides of the machine for a reference when you reassemble the parts (See Drawing Below).

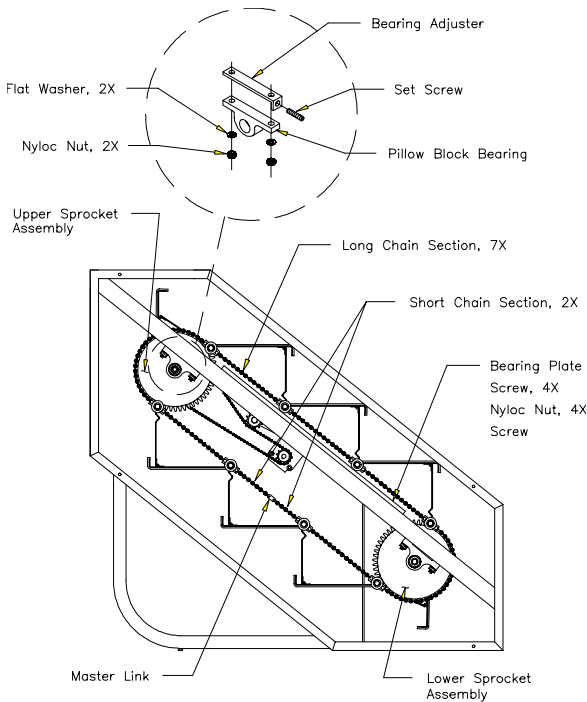

5. Remove the right and left step chain assemblies.
6. Loosen the adjustment screws until the tips of the screws are flush with the inside face of the bearing adjusters.





## PARTS REMOVAL AND REPLACEMENT

7. Have an assistant support the sprocket assembly. Loosen and remove the nuts on the pillow block bearing housing.
8. Remove the sprocket assembly from the frame.
9. Loosen the two set screws on both of the pillow block bearing collars and remove the pillow block bearings from the sprocket axle.
10. To reinstall the sprocket assembly:
  - Slide the pillow block bearings on both ends of the sprocket axle. Do not tighten the set screw on the pillow block bearing collars yet.
  - Place the bearing adjusters and the sprocket assembly onto the frame and start the pillow block bearing housing nuts onto the frame.
  - Slide the sprocket assembly toward the front of the machine while tightening the pillow block bearing housing nuts.
  - Align the sprocket assembly. The outside face of the left sprocket should be 1-11/16" (4.3 cm) from the outside edge of the left frame rail. Move the sprocket axle within the pillow block bearing collar as needed to get the correct distance.
  - When the distance is correct, tighten the pillow block bearing collar set screw on the left and right sides of the machine.
  - Loosen the pillow block bearing housing nuts slightly. Tighten the bearing adjuster set screws until the exact number of threads are exposed (refer to your notes taken earlier). Tighten the pillow block bearing housing nuts.
  - Check the alignment of the other sprocket at this time. If the distance from the outside edge of the left frame rail to the outside face of the sprocket is not 1-11/16" (4.3 cm), loosen the set screws on the left and right side pillow block bearing collars and adjust the axle. Tighten the pillow block bearing collar set screws on the machine and then go to step 11.

## PARTS REMOVAL AND REPLACEMENT

11. Complete the reassembly of the machine by performing steps 1- 4 in reverse order.

### CABLE ASSEMBLY

1. Remove the right side cover.
2. Remove the console and unplug the console cable from the back of the console (See Drawing Below). Unplug the plastic connectors at the console cable/main cable junction.

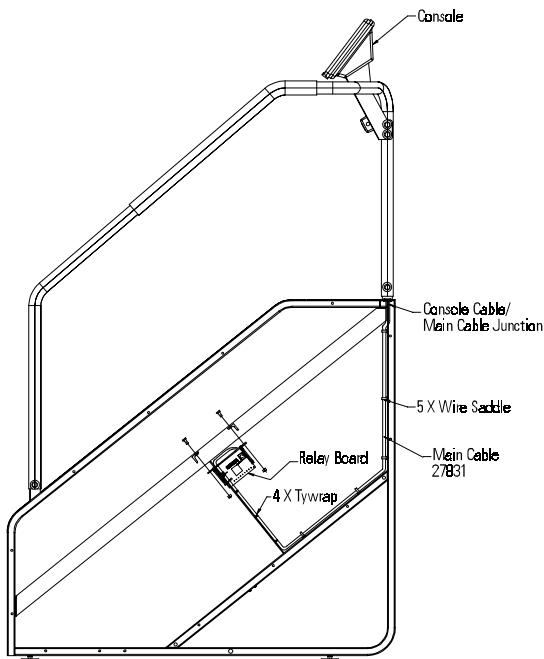

3. Hold the console connector and pull the console cable up and out of the handrails.
4. Reinstall the console cable by pushing the white plastic connector end down through the handrails. Do not connect the console, and the main cables.
5. Remove the main cable from the wire saddles.



## **PARTS REMOVAL AND REPLACEMENT**

6. Unplug the white plastic connector labeled J1 on the relay assembly circuit board.
7. Cut the four tyrap on the vertical support.
8. Remove the main cable from the frame.
9. To reinstall, place the main cable into the wire saddles. Reattach the cable to the vertical support with four tyrap.
10. Plug the white plastic connector of the main cable into the relay assembly circuit board at the spot labeled J1.
11. Plug the console cable into the back of the console. Reattach the console to the handrail mount. Plug the connectors together at the main cable/console cable junction.
12. Reinstall the right side cover. Reconnect the DC power cable.

## **TRANSMISSION ASSEMBLY**

1. Remove the left and right side covers.
2. Remove the step positioned in the middle of the staircase.
3. Remove the drive chain.
4. Remove the Poly-V belt. Inspect the belt for wear. Replace the belt if it is cracked, worn, torn, or cut.
5. Remove the transmission bracket by loosening and removing the mounting hardware on the alternator and the transmission.
6. Remove the transmission brace by loosening and removing the mounting hardware from the transmission and the frame.

## PARTS REMOVAL AND REPLACEMENT

- Support the transmission while loosening and removing the four transmission mounting bolts. Remove the transmission and rubber pad from the frame (See Drawing Below).

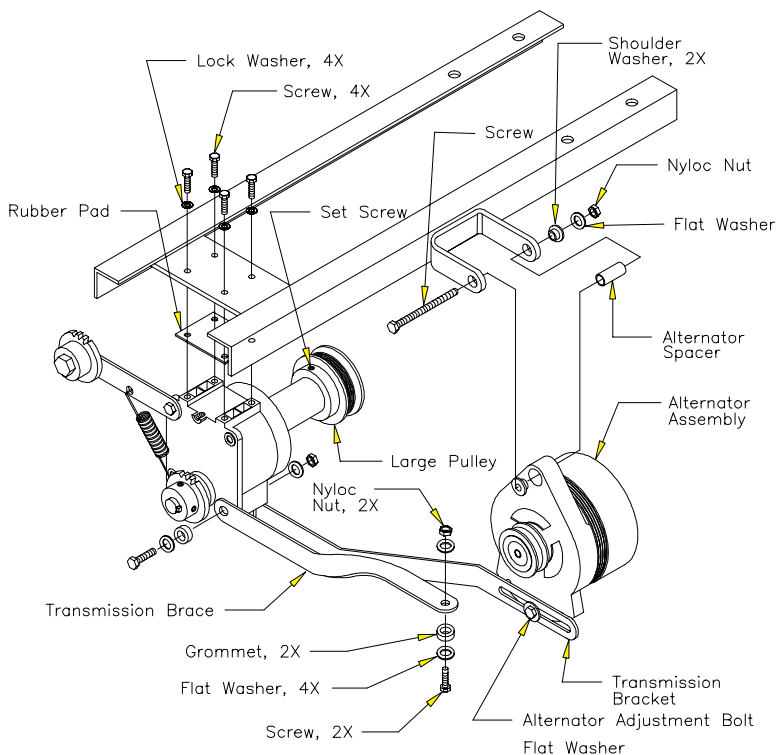

- Reinstall the transmission by reversing the removal procedures.
- Ensure the Poly-V belt is tensioned according to the procedures outlined in the "Poly-V Belt" section of this Manual.

### ALTERNATOR ASSEMBLY

- Remove the right and left side covers.
- Remove the step positioned in the middle of the staircase.
- Remove the wiring from the alternator terminals, noting the origin and color of the wires removed from each terminal.

## PARTS REMOVAL AND REPLACEMENT

4. Remove the Poly-V belt. Inspect the belt for wear. Replace the belt if it is cracked, worn, torn, or cut.
5. Remove the alternator adjustment bolt (See Drawing on Pg. 51).
6. Remove the nut, bolt and mounting hardware from the alternator bracket. Remove the alternator from the frame.
7. Reinstall the alternator by reversing the removal procedures. Be sure to verify the wiring connections.
8. Ensure the Poly-V belt is tensioned correctly (See Drawing Below).

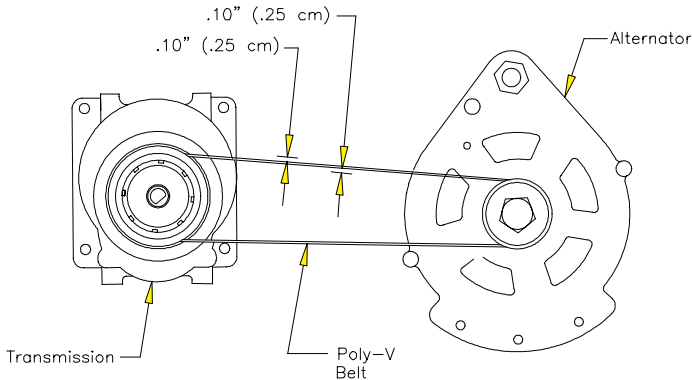

## RELAY/RESISTOR ASSEMBLY

1. Remove the left side cover.
2. Remove the step positioned in the middle of the staircase.
3. Remove the wiring from the alternator terminals, noting the origin and color of the wires that are removed from each terminal.
4. Unplug the main cable connector from the J1 position on the relay circuit board.

# PARTS REMOVAL AND REPLACEMENT

- Unplug the power connector from the J2 position on the relay circuit board.

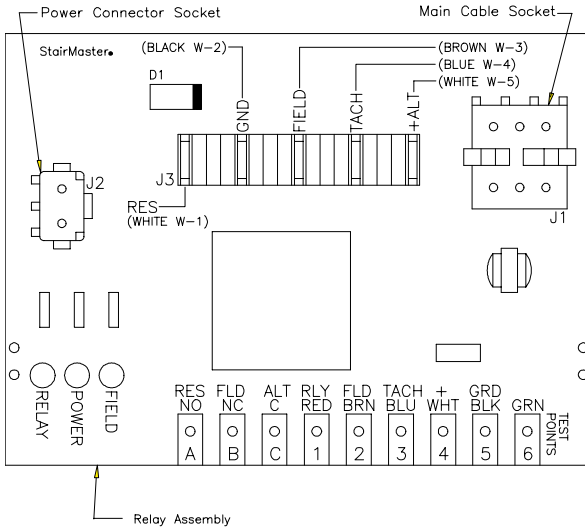

- Loosen and remove the four mounting bolts and remove the relay/resistor assembly from the frame.
- Reinstall the relay/resistor assembly in the reverse order. Verify the wiring connections before attaching the side cover.

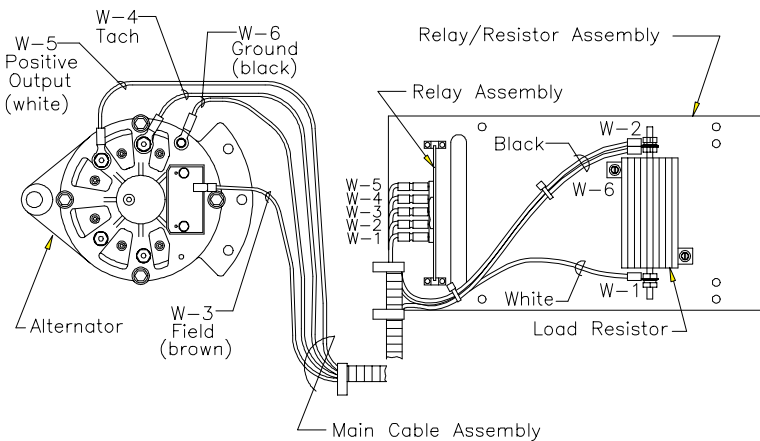

# GROUNDING INSTRUCTIONS

The machine must be grounded. If it should malfunction or break down, grounding provides the path of least resistance for the electric current, thereby reducing the risk of electric shock. This machine is equipped with a cord having an equipment-grounding conductor and a grounding plug that looks like the plug illustrated in sketch A in the Drawing below. International machines may vary. It must be plugged into an appropriate outlet that is properly installed and grounded in accordance with all local codes and ordinances.



**DANGER**

IMPROPER CONNECTION OF THE EQUIPMENT-GROUNDING CONNECTOR CAN RESULT IN THE RISK OF ELECTRIC SHOCK. CHECK WITH A QUALIFIED ELECTRICIAN OR SERVICE PERSON IF YOU ARE IN DOUBT AS TO WHETHER THE MACHINE IS PROPERLY GROUNDED. DO NOT MODIFY THE PLUG PROVIDED WITH THIS MACHINE. IF IT WILL NOT FIT THE AVAILABLE OUTLET, HAVE A PROPER OUTLET INSTALLED BY A QUALIFIED ELECTRICIAN.

A temporary adapter that looks like the adapter illustrated in sketches B and C may be used to connect this plug to a two-pole receptacle as shown in sketch B if a properly grounded outlet is not available. The temporary adapter should be used only until a properly grounded outlet (sketch A) can be installed by a qualified electrician. The green colored lug extending from the adapter must be connected to a permanent ground such as a properly grounded outlet box cover. Whenever an adapter is used, it must be held in place by a metal screw.

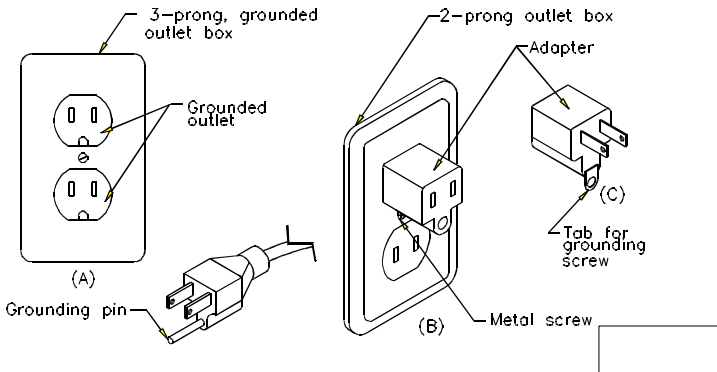

**Figure 5: Grounding System**

## FCC COMPLIANCE

This equipment has been tested and found to comply with the limits for a Class A digital device, pursuant to Part 15 of the FCC rules. These limits are designed to provide reasonable protection against harmful interference when the equipment is operated in a commercial environment. This equipment generates, uses, and can radiate radio frequency energy and, if not installed and used in accordance with the instruction manual, may cause harmful interference to radio communications. Operation of equipment in a residential area may cause harmful interference in which case the user will be required to correct the interference at his own expense.



### **WARNING**

CHANGES OR MODIFICATIONS TO EQUIPMENT NOT EXPRESSLY APPROVED BY STAIRMASTER® HEALTH & FITNESS PRODUCTS, INC. COULD VOID THE USER'S AUTHORITY TO OPERATE THIS EQUIPMENT.

## **CANADIAN DOC CLASS A COMPLIANCE**

This digital apparatus does not exceed the Class A limits for radio emissions from digital apparatus set out in the radio interference regulations of the Canadian Department of Communications.

La présent appareil numérique ne dépasse pas les limites établies pour les bruits radioélectriques applicables aux appareils numériques de la Class A prescrites dans les règlements sur le brouillage radioélectrique édicté par le Ministère des Communications du Canada.





## IMPORTANT PHONE NUMBERS

If you need assistance, please have both the serial number of your machine and the date of purchase available when you contact the appropriate StairMaster® Health & Fitness Products, Inc. office listed below.

### OFFICES IN THE UNITED STATES

#### CORPORATE HEADQUARTERS

12421 Willows Road NE, Suite 100  
Kirkland, WA 98034  
(800) 635-2936 or (425) 823-1825  
FAX: (425) 823-9490  
www.stairmaster.com

#### CUSTOMER SERVICE

12421 Willows Road NE, Suite 100  
Kirkland, WA 98034  
(800) 331-3578  
FAX: (425) 814-0601  
E-mail: customerservice@stairmaster.com

### INTERNATIONAL OFFICES AND DISTRIBUTORS

For technical assistance and a list of distributors in your area, please call or fax one of the following numbers.

#### INTERNATIONAL DIVISION

(425) 823-1825  
FAX: (425) 820-7505  
E-Mail: intlservice@stairmaster.com

#### ASIA PACIFIC HEADQUARTERS

Telephone/Fax: +81-45-590-5686  
E-mail: stairintl@aol.com

#### EUROPE: HEADQUARTERS

+41-91-827-3801  
FAX: +41-91-827-8902  
E-Mail: stairmasterch@swissonline.ch

#### GERMANY: HEADQUARTERS

+49-2204/610-27  
FAX: +49-2204/628-90  
E-Mail: stairmaster.de@t-online.de

#### U.K.: HEADQUARTERS

+44-1908/267-345  
FAX: 44-1908/267-346  
E-mail: stairmasteruk@msn.com

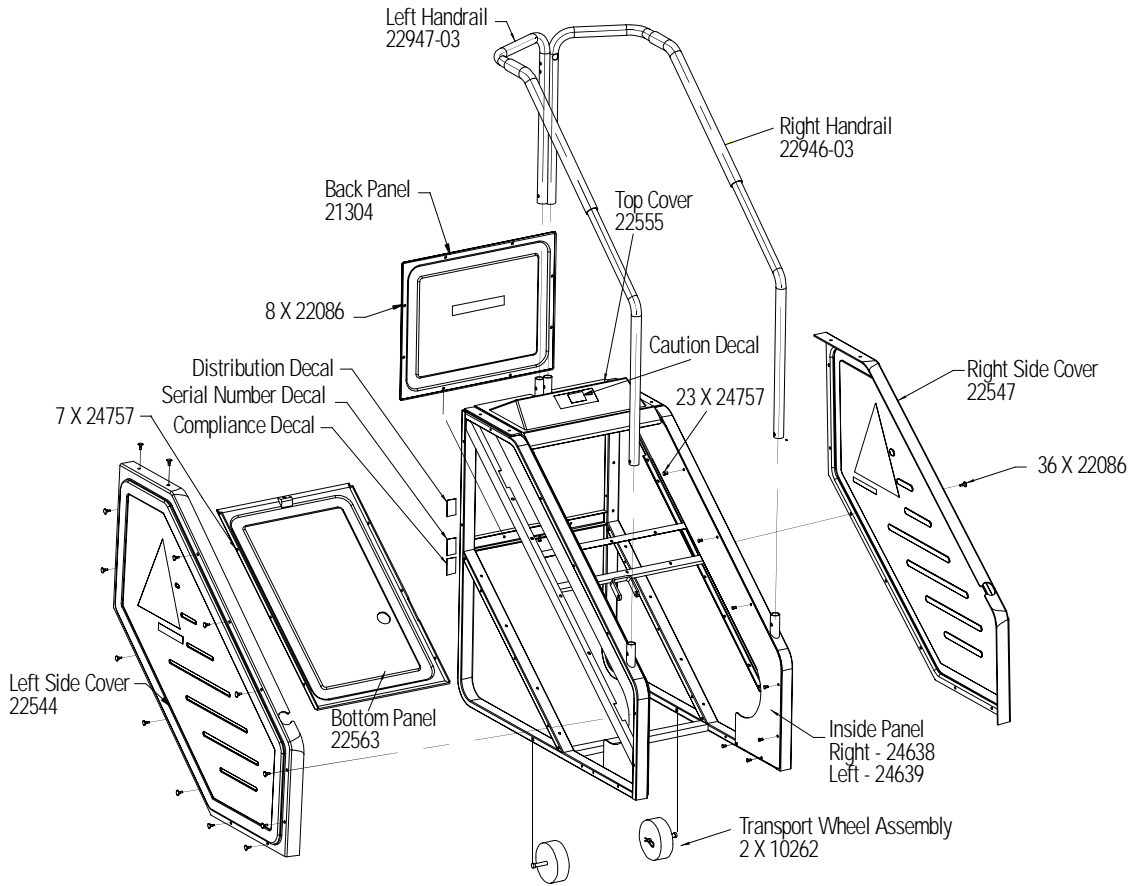
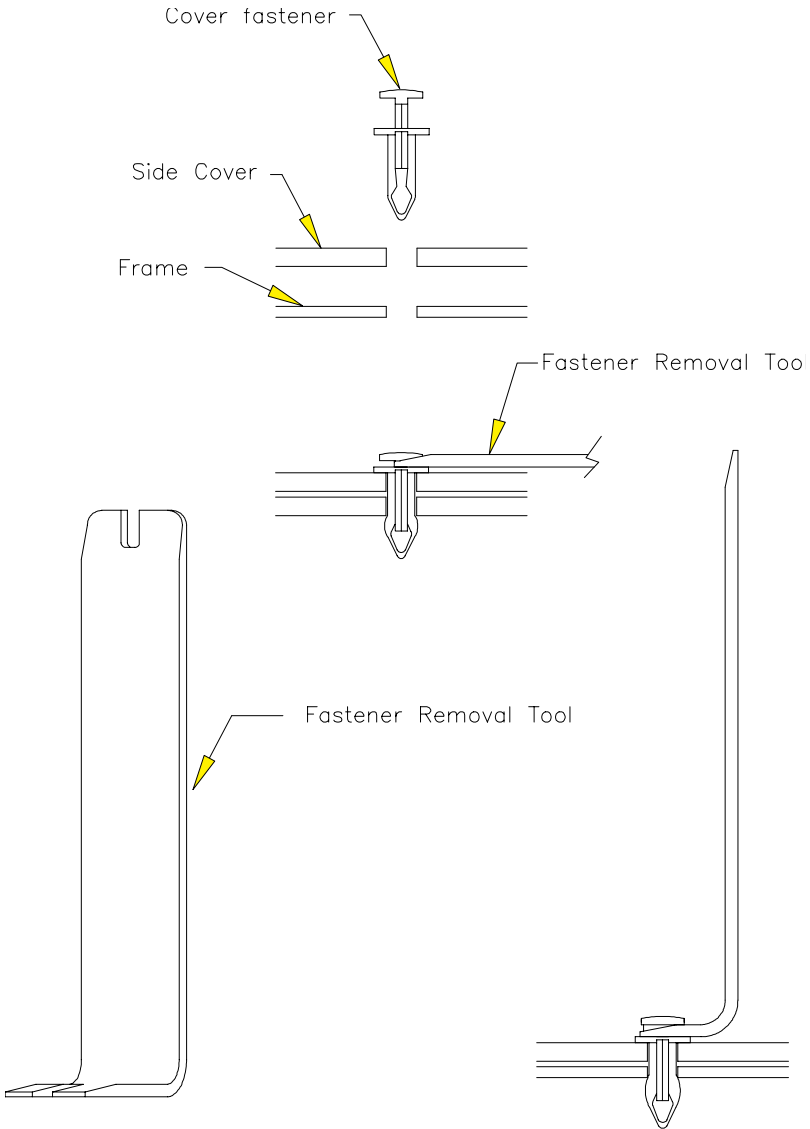

Figure 6: Side Cover and Handrail Assemblies



# FIGURES

## Figure 7: Cover Fasteners



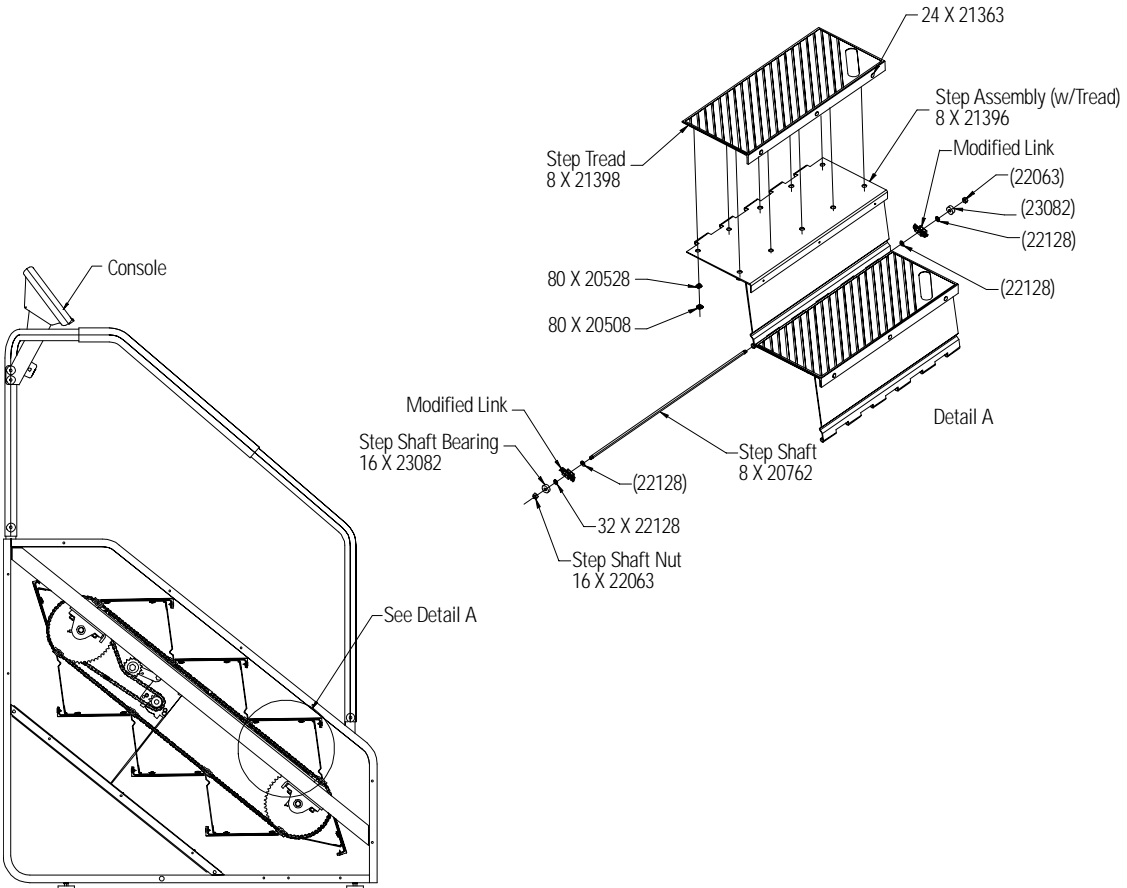

Figure 8: Step Assembly

Figure 9: Step Chain and Sprocket Assemblies

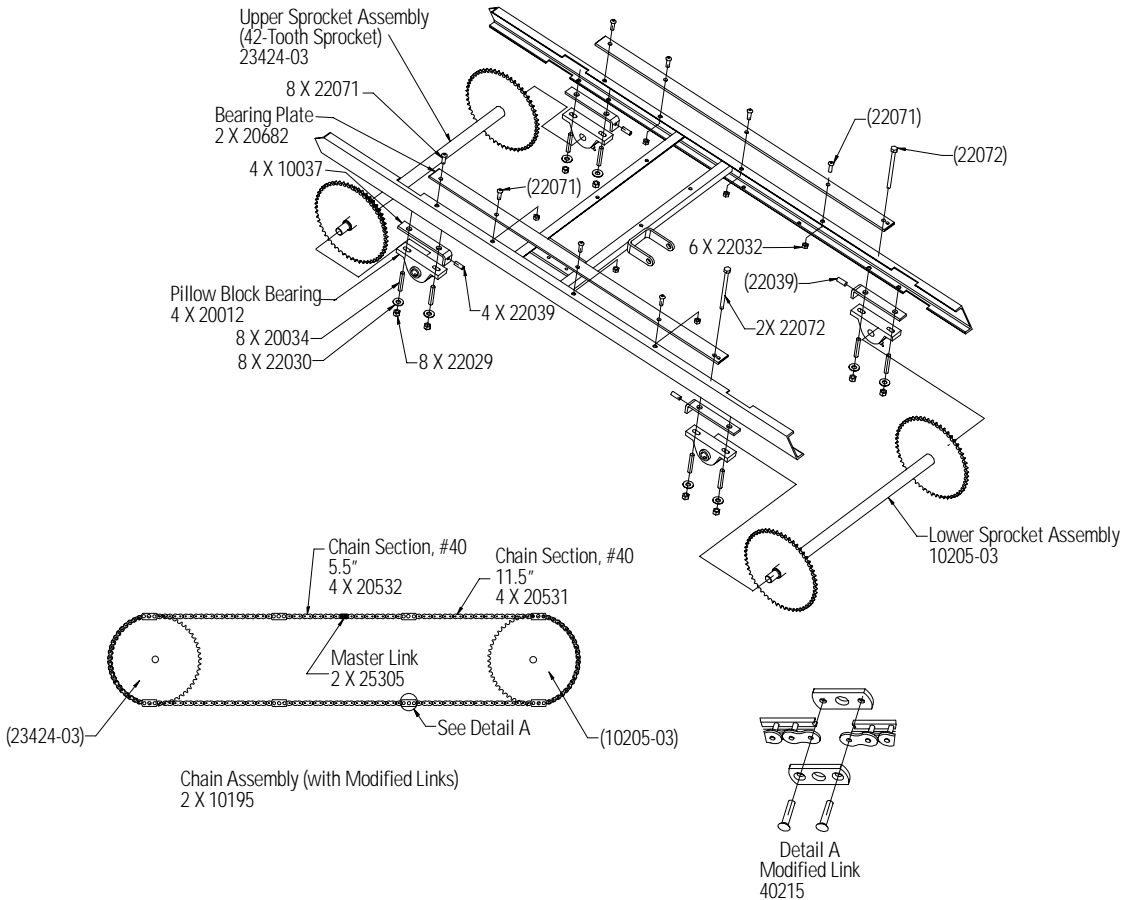

Figure 10: Transmission and Alternator Assemblies

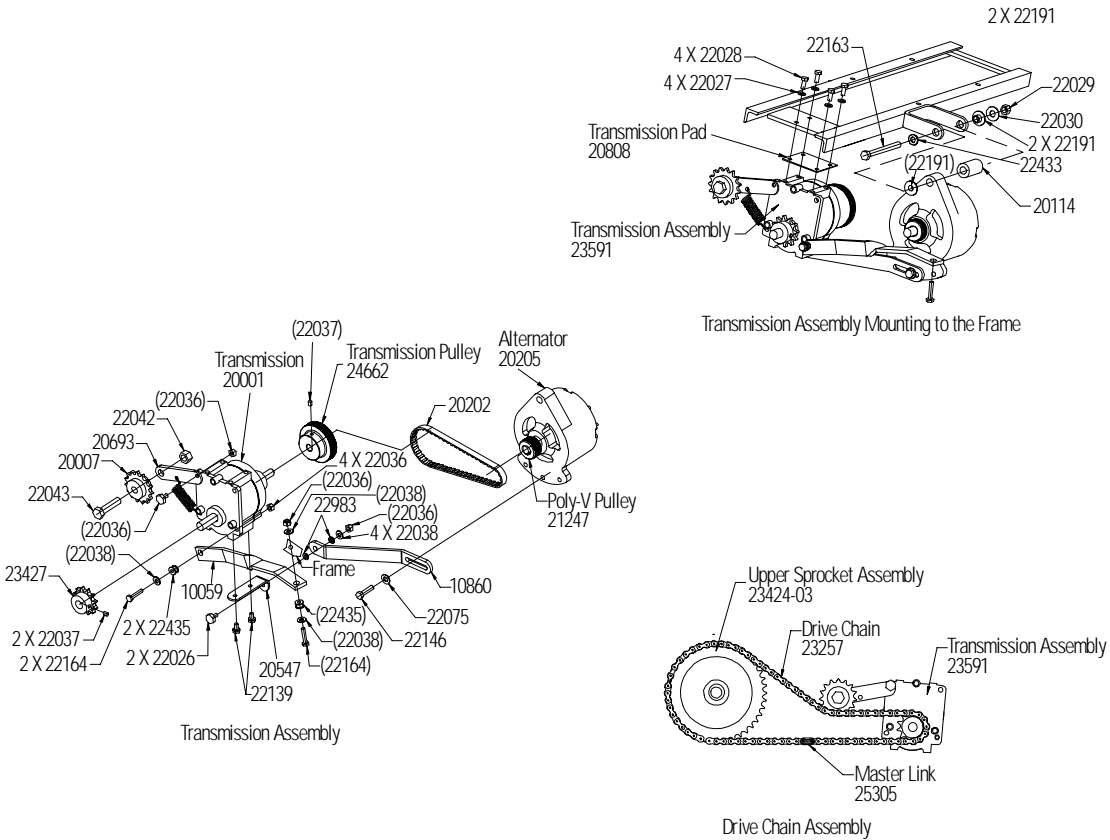

Figure 11: Wiring Diagram

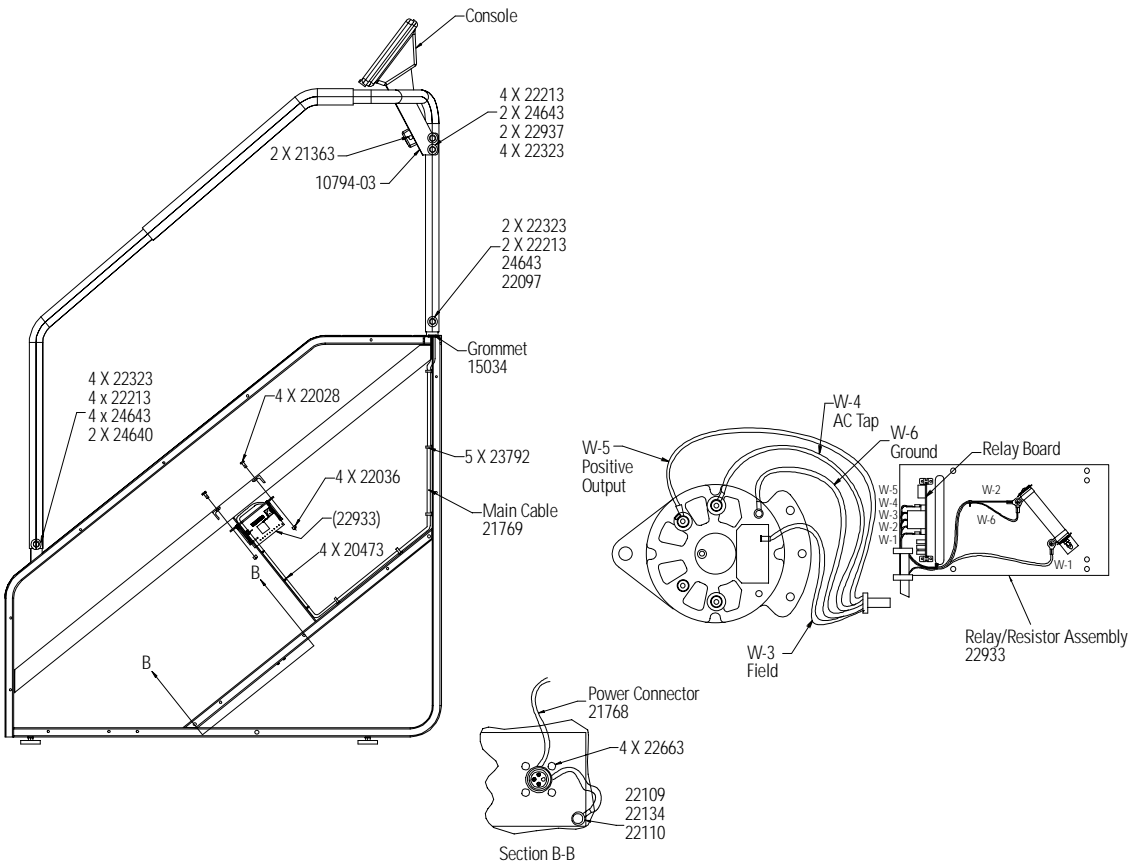

Figure 12: Relay Board

